

# INSTRUCTION MANUAL

INSTRUMENT SOFTWARE 3.0

A sound level meter with built-in real time analyser capabilities complying with international instrument standards. Parallel octave filters are standard (optional in some markets), but the impressive list of optional extensions include third octave filters and statistics in every frequency band, multispectrum, reverberation time measurements, and recording for the measured sound. The instrument logs level vs. time (optional) and when it is equipped with multiple time constants and the enhanced profile extension, a multitude of functions is logged simultaneously. The more than 120 dB dynamic range eliminates the need for range setting. A large memory, SD-card and high-speed data transfer rates complete a user-friendly solution.

# nor140

SOUND ANALYSER



**Ni** Norsonic



**nor140**  
SOUND ANALYSER

## **Nor140 User Guide – September 2013 Edition**

Im140\_1Ed6R0En

Norsonic is a registered trademark of Norsonic AS. All other brand or product names are trademarks or registered trademarks of their respective companies.

Every effort has been made to supply complete and accurate information. However, Norsonic AS assumes no responsibility for the use of – nor for the consequential damages of the use of – this information and/or the instrumentation described herein. Furthermore Norsonic AS assumes no responsibility for any infringement of the intellectual property rights of third parties, wherever applicable, which would result from such use.

Norsonic AS reserves the right to amend any of the information given in this manual in order to take account of new developments.

If you wish to communicate with us, please feel welcome.

Our address is:

**Norsonic AS, P.O. Box 24, N-3421 Lierskogen, Norway**

**Find us on the web:** [www.norsonic.com](http://www.norsonic.com)

**Tel:** +47 3285 8900,

**Fax:** +47 3285 2208

**e-mail:** [info@norsonic.no](mailto:info@norsonic.no)

**Copyright © Norsonic AS 2013 All rights reserved**



# Finding the information you need

Thank you for choosing Norsonic! The Nor140 has been designed to give you many years of safe, reliable operation.

Your approach to the Nor140 documentation depends on what you want to do and how much you already know.

The *Nor140 Instruction Manual* is divided into several sections plus an index. Each section provides useful and in depth information about the measurement features. Depending on your requirements and your familiarity with sound measurements as such, you may find that you use some parts of this manual quite often and others not at all.

Note that the instruction manual describes a fully equipped instrument. Your version may not have all the optional extensions available. Extensions may, however, be installed as retrofit any time.

Detailed technical specifications are found in the last regular paragraph.

Our objective with this manual has been to address your goals and needs. Please let us know how well we succeeded!

# Contents

<b>Chapter 1</b>	<b>Introducing the Nor140 sound level meter.....</b>	<b>2</b>
	Modular design.....	2
	The functions available.....	2
	The MODE and SETUP buttons.....	2
	Global and Mode dependent parameters.....	2
	The main features – an overview.....	3
	Real time frequency analysis.....	4
	Time profile measurements.....	5
	Multispectral measurements.....	6
	Source coding.....	6
	Recording the sound.....	7
	Excellent for noise monitoring.....	7
	The principle of optional extensions.....	7
	Transducers.....	7
	Check which extensions are installed.....	8
	Workload.....	8
<b>Chapter 2</b>	<b>Taking a closer look at the instrument.....</b>	<b>11</b>
	Switching ON/OFF.....	11
	On the use of batteries.....	11
	Low Voltage Situations.....	12
	Marks on the lower line of the display.....	14
	The input menu.....	15
	Selecting language.....	15

<b>Chapter 3</b>	<b>Calibrating the instrument .....</b>	<b>17</b>
	When to calibrate .....	17
	No need to adjust the full scale setting .....	17
	Carrying out the calibration .....	17
<b>Chapter 4</b>	<b>Simple sound measurements .....</b>	<b>21</b>
	Setting the duration .....	21
	Statistics .....	22
	Instruments with time profile installed .....	23
	Setting the time constant.....	23
	Instruments with multiple time constants .....	23
	Multiple time constants and statistics .....	23
	C or Z as spectral weighting network.....	23
	Resuming an ended measurement.....	25
	The back-erase function.....	25
	Displaying the functions measured.....	25
	Displaying the result tables .....	26
	Statistics – displaying the percentiles .....	27
	Displaying the percentiles table.....	28
	Storing the acquired data.....	28
	Printing out the results.....	28
	User defined table.....	29
<b>Chapter 5</b>	<b>Frequency analysis .....</b>	<b>30</b>
	Setting the measurement duration .....	30
	Statistics .....	31
	Instruments with time profile installed .....	31
	Consider setting the time constant .....	31
	Setting C or Z as spectral weighting network .....	31
	Finding the energy level over a part of the frequency range .....	32
	Activating the frequency mode .....	32
	Switching to displaying the spectrum .....	33
	Making a frequency analysis .....	33
	Resuming an ended measurement.....	34
	The back-erase function.....	34
	Displaying the functions measured.....	35

	No <b>SPL</b> after the measurement .....	35
	Displaying the result tables .....	35
	Statistics – displaying the percentiles .....	38
	Storing the acquired data.....	39
	Printing out the results.....	39
	NC, NR and RC rating .....	40
<b>Chapter 6</b>	<b>Basic time profile measurements.....</b>	<b>41</b>
	Global vs. profile.....	41
	Making measurements .....	44
	Presenting the L(t) as a table .....	45
<b>Chapter 7</b>	<b>Enhanced time profile measurements.....</b>	<b>46</b>
	Selecting which functions to log .....	46
	Copy the setting to Prnt/Xfer .....	47
	Setting the time resolution .....	47
	Measuring in enhanced mode .....	49
	Displaying the functions measured.....	49
	Presenting the L(t) as a table .....	49
<b>Chapter 8</b>	<b>Adding markers to a measurement.....</b>	<b>50</b>
	The keys to use.....	50
	Other markers inserted by the instrument.....	51
	Instrument markers have priority.....	51
	Marker overview .....	51
<b>Chapter 9</b>	<b>Multispectrum measurements.....</b>	<b>52</b>
	Setting up for multispectrum .....	52
	Instruments equipped with basic profile extension .....	52
	Making multispectrum measurements .....	53
	The result tables .....	55
<b>Chapter 10</b>	<b>Engineering units.....</b>	<b>58</b>
	Introduction.....	58
	Selecting Engineering Units .....	58
	How values are indicated .....	58

	Relation between dB and EU .....	59
	Calibration .....	59
<b>Chapter 11</b>	<b>Memory handling.....</b>	<b>61</b>
	Memory structure .....	61
	Select the device for storing.....	62
	SD-card memory.....	62
	Format.....	62
	Storing a measurement setup .....	62
	General.....	63
	Global parameters.....	63
	Mode dependent parameters .....	64
	Storing a measurement .....	64
	Retrieving stored setups and data .....	64
	Standard set-up.....	65
	Clearing files and folders in the memory .....	67
	Clearing a single file .....	67
	Clearing folders or the entire memory.....	68
<b>Chapter 12</b>	<b>Automatic storing of data and noise monitoring.....</b>	<b>69</b>
	Automated storage of measured data.....	69
	Available storage modes.....	69
	Synchro – an example.....	70
	Setting the storage mode.....	71
<b>Chapter 13</b>	<b>Making hardcopies.....</b>	<b>72</b>
	Setting up for printouts .....	72
	Printing out measured data .....	72
<b>Chapter 14</b>	<b>Transfer of data to a PC.....</b>	<b>74</b>
	Select USB or serial.....	75
	Password.....	75
	NorXfer installation procedure.....	75
	Installing from the Norsonic Application CD.....	75
	Installing from the Norsonic website .....	77
	Installation of USB drivers for Nor140 .....	77

	Quick Reference Guide – transfer and convert a measurement to Excel .....	80
	Virtual Instrument – Nor1036 Installation procedure.....	82
	Using Virtual Instrument Nor1036 .....	82
<b>Chapter 15</b>	<b>Signal input and output .....</b>	<b>83</b>
	Signal input.....	83
	IEPE .....	83
	Noise output .....	84
	RPM .....	84
	Signal output.....	84
<b>Chapter 16</b>	<b>Trigger.....</b>	<b>85</b>
	General .....	85
	Setting the trigger condition.....	86
	Manual trigger .....	86
	Clock trigger.....	86
	External trigger .....	87
	Level above-trigger .....	87
<b>Chapter 17</b>	<b>Recording the sound .....</b>	<b>89</b>
	Formats.....	89
	Recording gain .....	89
	Recording duration.....	90
	Making a recording .....	90
	Setup for a recording.....	91
	Setup how to start a recording .....	91
	Manual trigger .....	91
	External trigger .....	91
	Level above-trigger .....	92
	Listening .....	92
	Insert a reference tone as a recording .....	93
<b>Chapter 18</b>	<b>Reference Spectrum .....</b>	<b>94</b>
	General .....	94
	Activating the Reference Spectrum features .....	94
	Selecting the Reference Spectra .....	94

	Using a previously measured spectrum .....	95
	Entering a new Reference Spectrum manually .....	95
	Editing a selected Reference Spectrum .....	96
	A-pre-weighted Reference Spectrum .....	96
	“Go / NoGo” Quality Control feature .....	96
	Digital output lines .....	97
<b>Chapter 19</b>	<b>Noise Generator .....</b>	<b>98</b>
	General .....	98
	Selecting noise type and level .....	98
	Adjustments for reverberation measurement .....	99
	Standard Set Up .....	99
	Equalization of the noise spectrum .....	99
<b>Chapter 20</b>	<b>Compensation and correction .....</b>	<b>100</b>
	General .....	100
	Use of windscreen .....	100
	Preamplifier correction .....	101
	Random incidence and diffuse sound fields .....	101
	Measurement of low sound levels .....	101
	Measuring the self-noise .....	102
	Measurement of high sound levels .....	102
<b>Chapter 21</b>	<b>Reverberation time measurements .....</b>	<b>104</b>
	What is reverberation time? .....	104
	Calculating the reverberation time .....	105
	Measurement with noise excitation .....	105
	Measurement with impulse excitation .....	105
	Measurement with swept sine excitation .....	107
	Implementation in Nor140 .....	108
	Excitation signals .....	109
	Minimum reverberation time possible .....	109
	Maximum reverberation times .....	109
	Measuring according to the integrated impulse response method .....	111
	Measuring according to interrupted noise method .....	113
	Measuring according to the Swept Sine method .....	115

**Chapter 22**

**Sound Power..... 117**

- About sound power measurements ..... 117
- Rectangular parallelepiped ..... 118
- Hemispherical measurement surface ..... 118
  - Hemispherical microphone positions ..... 119
  - Additional microphone positions ..... 119
- Parallelepiped measurement surface ..... 121
  - Microphone positions..... 121
  - Additional microphone positions ..... 121
  - Reducing the number of positions..... 122
  - Mic. positions – one reflecting plane..... 122
  - More than one reflecting plane..... 122
- Sound power – acoustic environment requirements..... 124
- Specific requirements ..... 125
- The  $K_{2A}$  factor ..... 125
- Approximate method ..... 125
- Using reverberation time instead ..... 125
- Test room qualification requirements ..... 126
- Measuring the sound power..... 126
- Making measurements ..... 126
- Background noise ..... 129
- Measurement surface..... 129
- Sound power results..... 130

**Chapter 23**

**Building Acoustics..... 131**

- Introduction..... 131
  - Terms and definitions for airborne sound insulation..... 133
  - Terms and definitions for impact sound insulation ..... 134
  - Survey and engineering methods..... 134
- Airborne sound insulation..... 135
  - General..... 135
  - Noise excitation..... 135
  - Measurement of sound level..... 135
  - Measurement of reverberation time ..... 135
- Calculating the Airborne and insulation according to the Survey Method ..... 136
  - Displaying of results..... 136



Calculating the Airborne sound insulation according to the Engineering method .....	138
Source room level .....	138
Receiving room level.....	139
Background noise.....	139
Reverberation time.....	139
Display of results.....	139
Spectrum adaptation terms .....	141
Store and recall .....	141
Averaging levels or level-differences .....	142
Equalizing the excitation level .....	143
Impact sound insulation .....	144
Impact excitation .....	144
Measurement of sound level.....	144
Reverberation time.....	144
Calculating the Survey result.....	144
Calculating the impact sound insulation according to the Engineering method .....	145
Receiving Room Level .....	145
Background noise.....	146
Reverberation time.....	146
Display of results .....	146
Store and recall .....	147
Partly re-use of previous measurements.....	147
Facade insulation .....	148
General .....	148
Terms and definitions.....	148
Noise excitation.....	149
Measurement of sound level.....	149
Measurement of reverberation time .....	150
Calculating the result .....	150
Service equipment sound pressure levels – Survey method.....	150
Remote operation from a PC .....	151
Swept-Sine measurement technique .....	151
Swept-Sine measurement of sound level .....	151
Swept-Sine measurement of reverberation time.....	152

<b>Chapter 24</b>	<b>Speech Intelligibility by STIPA..... 153</b>
	Introduction – What is STIPA ..... 153
	Speech transmission index – STI ..... 153
	Development of STI ..... 153
	RASTI and STIPA..... 154
	How is STIPA measured ..... 155
	CIS ..... 156
	Units included in delivery ..... 156
	Software option for Nor140..... 156
	CD for excitation ..... 156
	CD with Excel sheet ..... 156
	Measurement overview ..... 157
	General instrument description ..... 157
	Selecting a loudspeaker for the excitation ..... 158
	Loudspeaker or electrical excitation ..... 158
	Performing a measurement ..... 159
	Set-up ..... 159
	Set the speech level ..... 159
	Select the STI-mode ..... 159
	Making a measurement ..... 159
	Store and recall the result ..... 160
	Correcting for background and occupancy noise ..... 161
	Real background noise ..... 162
	Precision of the STIPA method ..... 162
	Analysis and interpretation of the results ..... 163
	Limitations of the STIPA method ..... 163
	Using Excel for further calculations ..... 163
	STI-Calc ..... 163
	Specifications ..... 164
<b>Chapter 25</b>	<b>FFTmeasurement mode..... 165</b>
	Introduction..... 165
	How to select the FFT-mode ..... 165
	Making a measurement ..... 165
	Calibration ..... 166

	Corrections .....	166
	Storing the result.....	167
	Specification for FFT .....	167
<b>Chapter 26</b>	<b>Measuring vibration using the Nor140.....</b>	<b>168</b>
	Introduction.....	168
	Accelerometer .....	168
	IEPE-type.....	169
	Charge type.....	171
	Velocity and displacement .....	171
<b>Chapter 27</b>	<b>Audiometer calibration .....</b>	<b>173</b>
<b>Chapter 28</b>	<b>Technical specifications.....</b>	<b>174</b>
	Type of instrument .....	174
	Analogue inputs .....	174
	Microphone input socket	
	.....	175
	Highpass filter .....	175
	Analogue to digital conversion.....	175
	Frequency weightings .....	176
	Weighting networks.....	176
	Filters.....	176
	Level detector.....	176
	Time weightings and measured functions .....	176
	Level distribution .....	177
	Indication range.....	177
	Self-noise levels.....	177
	Z-wide considerations .....	177
	Measurement duration and resolution .....	178
	Timing accuracy.....	178
	Measurement range .....	179
	Power supply .....	179
	Display .....	180
	Keyboard .....	180
	Adjustment of indicated levels .....	180

Windscreen.....	181
High levels .....	181
Preamplifier attenuation.....	182
Self-noise compensation .....	183
Diffraction around the instrument casing .....	183
Signal output.....	185
Serial I/O port .....	185
Digital inputs.....	185
Digital outputs.....	185
Digital output control lines.....	186
AC-out .....	187
RPM .....	187
USB interface .....	187
SD-card .....	187
Data storage .....	187
Environmental conditions .....	187
Warm-up time .....	188
Sensitivity for vibration.....	188
Sensitivity for magnetic fields.....	188
Size and weight .....	188
Information for conformance testing .....	188

**nor140**  
SOUND ANALYSER

# Introducing the Nor140 sound level meter

## Modular design

The Nor140 comes with an extensive set of functions available in its basic version. Many other functions are available as optional extensions.

The modular design of the Nor140 enables functional expansion to take place when you need it and not necessarily at the time you purchase the instrument. All installed options remain in the instrument and there is no need for further loading of the options when used.

## The functions available

Even in the basic version the functions available with the Nor140 include the following:

- SPL The Instantaneous Sound Pressure Level
- $L_{MAX}$  The Maximum Sound Pressure Level
- $L_{MIN}$  The Minimum Sound Pressure Level
- $L_{eq}$  The Integrated Averaged SPL
- $L_E$  The Sound Exposure Level
- $L_{PEAK}$  The Maximum Peak Level

The spectral weighting functions A- and C- or Z-weighting are available for all functions including the  $L_{PEAK}$ .

The Z-weighting as specified in IEC 61672-1 replaces Lin or Flat as these have not been properly defined by any standard.

As an optional extension the instrument functionality can be expanded to include the ability to measure with all three time constants (F, S, I) applied simultaneously.

## The MODE and SETUP buttons

Two buttons are often used to change the behaviour of the instrument.

The MODE button selects the main operating modes. In the rest of this instruction manual it is assumed you are in Level Mode unless otherwise is indicated.

The SETUP button activates the set up menu system that is different dependant on the operating mode.

## Global and Mode dependent parameters

Several set up parameters are valid for all types of operation of this analyser, while others are mode dependent. These parameters, which are not global, can be adjusted in one mode of operation for the



instrument without affecting the value of the same parameters in another mode of operation. If you close a mode and return to it later, the value last used for these parameters will be automatically loaded.

### The main features – an overview

**Level vs. time.** The electronic level recorder concept is available in two versions – basic and enhanced. While the basic version logs the equivalent level, the maximum level and the peak level, the enhanced version is capable of logging any combination of functions available with the Nor140. In addition it allows source coding.

Another difference important for some applications is that while the basic version has a time resolution ranging from 1 second and upwards, the enhanced version has a time resolution from 50 ms and upwards in 25 ms steps. Above 1 second the time resolution is available in 1 second steps for both versions.

**Frequency analysis.** When fitted with the frequency analysis extensions the Nor140 can make real time frequency analysis in octaves or third-octaves.

The functions measured are the equivalent level, the maximum level and the minimum level.

The frequency range is 0,4 Hz to 20 kHz and thus covers both the audio and the vibration range.

**Statistics.** The optional extension 4 adds statistical distribution to the Nor140 functionality. There are eight percentiles shown, out of which one is freely selectable. The class width is 0.2 dB over the entire 130 dB range.

The statistical distribution calculation applies to the spectral weighting networks (A and Z or C) as well as all the individual filter bands (if applicable).

The back-erase feature, which deletes up to 20 (selectable 0 - 20) of the most recent seconds of acquired global data prior to a pause upon resuming, updates the statistics buffers as well to maintain consistency.

For the statistical sampling the instrument makes use of the F time constant, irrespective of what time constant(s) the frequency analysis as such employs.

The fixed percentile levels offered by option 4 are 1.0%, 5.0%, 10.0%, 50%, 90%, 95% and 99%.

In addition, one of these percentiles is subject to user-definition and can be set to anything from 0.1% to 99.9%, both extremes included. Note that you don't have to define the percentile prior to the measurement. You may redefine the percentile as many times as you like – even after the measurement! For every frequency band measured!

However, once you start another measurement or switch off the instrument, only the selected percentiles will be available to keep the amount of stored data lower.

**Reverberation time.** A typical Nor140 application is to serve as the acoustician's little blue tool. This will require the ability to calculate the reverberation time in octaves and third-octaves. Units without filters will calculate the broadband values (A- and C- or Z-weighted values). As usual, this is an optional feature so if you don't need it, you won't have to pay for it either.

The reverberation time algorithm may be based on the *integrated impulse response* method or the *interrupted noise* method. Hence, impulses are required as excitation signals, or noise excitation from the internal signal generator may be applied.

**Noise monitoring and mapping.** The large memory and the time synchronising capabilities of the Nor140 makes it well-suited as a front end in noise monitoring systems – outdoors for community noise as well as indoors in workshops etc.

The high dynamic range (120 dB) makes the setup easy and ensures reliable measurements in all situations. The Norsonic product range contains a wide range of equipment and accessories for use with noise monitoring and measurements. We supply enclosures for permanent monitoring installations, environmental cases for semi-permanent installations, microphones for applications in tough environments, cables, modems, weather stations and post-processing software. A detailed presentation of this is available in a separate leaflet and on [www.norsonic.com](http://www.norsonic.com).

## Real time frequency analysis

Octave band or third-octave band measurements – the choice is yours, depending on how you prefer to configure your Nor140.

The octave band measurements span the range 8 Hz to 16 kHz, or from 0,5 Hz to 16 kHz dependent

on your set-up. An upgrade to option 3 will provide you with third-octave band measurements in the range 6,3 Hz to 20 kHz or from 0,4 Hz to 20 kHz.

The two bandwidths share the type of functions measured. In a single frequency analysis the Nor140 measures:

- SPL The Instantaneous Sound Pressure Level
- $L_{MAX}$  The Maximum Sound Pressure Level
- $L_{MIN}$  The Minimum Sound Pressure Level
- $L_{eq}$  The Integrated Equivalent SPL
- $L_E$  The Sound Exposure Level

While the measurement is running the instantaneous SPL is available for inspection, but as soon as the measurement is terminated the SPL becomes meaningless and therefore not listed in the result tables.

If your Nor140 is equipped with parallel time constants (option 5), the list of functions measured simultaneously can be expanded to include functions with F, S and I time constants at the same time.

The frequency bands measured are all visible in the display with no need for horizontal scrolling. The **f↔t** key lets you enter and exit the spectrum display. Furthermore, the instrument measures the selected full frequency range – every time! Given the high dynamic range (120 dB), which eliminates the need for adjusting the gain, there is very little to set up before a frequency analysis can be made – successfully!

The measured functions are also available in tabulated form as numerical values. By pressing the **TBL** key before, during or after a measurement you have instant access to the numerical version. Another push on the key will restore the graphical display.



**Statistics.** Adding option 4 to your Nor140 will expand your frequency analysis to even calculate the statistical level distribution for each frequency band measured! In addition statistics will be calculated for the two spectral weighting networks employed (A- and C- or Z-weighting). The class width is always 0,2 dB to ensure sufficient resolution and the results are presented in the form of eight percentiles with a resolution of 0,1dB.

## Time profile measurements

With Nor140 instruments equipped with the optional extension 6 you will be able to retain all the advantages of the analogue level recorder principle, while at the same time discarding all the trouble!

The optional extension 6 – level vs. time – records the time profile of the A-weighted equivalent level, the A-weighted maximum sound pressure level and the Z- or C-weighted peak level – simultaneously!

The principle is based on dividing the measurement into periods of identical duration. The period duration can be from 1 second and upwards in 1 second steps (from 50ms in enhanced mode).

When a level vs. time measurement is running, the equivalent level will be calculated per period, thus giving you the time profile for the measurement.

The MAX and the PEAK levels are also recorded per period so that all three functions will yield a value for every period.

When you are going to make a measurement, the maximum number of periods at your disposal will depend entirely on the amount of free memory available.

Given the large memory of the Nor140 the period duration will for all practical cases be determined by your need for time resolution.

**Provide details – maintain overview.** The level vs. time feature is the tool you need for detailed analysis of the time profile. However, a measurement failing to provide an overview of the entire analysis cannot be accepted.

So, we added a global analysis to all time profile measurements. It just runs in the background and makes little fuss about its presence.

Switching between global and profile is easy, a dedicated key on the front panel – the  $\Sigma \leftrightarrow \Delta$  key – lets you toggle between the two. The  $\Sigma$  (pronounced “sigma” often used for a sum) denotes the global analysis while the  $\Delta$  (pronounced “delta”) denotes the time profile.

Consequently, when you have set up for a time profile measurement by defining the total duration and the time resolution, you have in fact prepared the instrument for two parallel measurements – the global and the profile!

**Absolute vs. relative time.** The instrument contain a calendar and an accurate clock and all measurement are stored with the date and the time of the day. By pressing the **ABS t** key, you may toggle between displaying the absolute time when the data were acquired, or the time relative to the start of measurement (duration). This is a display function – the absolute time is always recorded for all measurements.

**Setting up is easy to do.** After you’ve defined the duration and the resolution, all you need to do before you press the **START** key, is to define the time constant and whether to use Z- or C-weighting as the secondary spectral weighting function.

During the measurement you have instant access to the global analysis and profile. For each of these the function key lets you inspect all the functions measured.

For the global analysis the functions measured are the instantaneous SPL, the maximum and the minimum SPL, the equivalent level, the sound exposure level and the maximum peak level. All levels are measured as A-weighted and Z- or C-weighted levels.

The time profile logs the A-weighted equivalent level, the A-weighted maximum sound pressure level and the Z- or C-weighted peak level.

**The enhanced profile option.** In need of even better resolution or better control of the functions measured? No problem! The time profile extension can be expanded into the enhanced profile extension – our option 7 for the Nor140. Order it when you purchase your Nor140 or later, if that suits you better.

In the enhanced mode, the instrument logs the time profile of the same functions as with the global:

- SPL The Instantaneous Sound Pressure Level
- $L_{MAX}$  The Maximum Sound Pressure Level
- $L_{MIN}$  The Minimum Sound Pressure Level
- $L_{eq}$  The Integrated Equivalent SPL
- $L_E$  The Sound Exposure Level
- $L_{PEAK}$  The Maximum Peak Level

If you then add the option 5, parallel time constants, you may set up the instrument to log any combination of functions and time constants, for example the SPL with S time constant and the maximum SPL with F time constant simultaneously.

**Enhanced time resolution as well.** The enhanced profile has a time resolution which can be from 50 ms and upwards in 25 ms steps (in 1 second steps above 1 second time resolution), so beware unless you want

to create a busy day for yourself – there will easily be quite a lot of data generated, so avoid more details than strictly needed!

## Multispectral measurements

The Nor140 functionality can be expanded to include multispectral measurements. This extension takes the instrument's time profile capabilities to new heights by allowing complete spectra to be logged as a function of time.

## Source coding

Have you ever made a measurement where you later found out that you desperately need to know what caused the level to be what it turned out to be?

Enter *source coding*. With the enhanced profile option you may tag or code sources as they happen. A one digit code (which appears in the display as 1~4) is entered to later serve as an identification of the type of noise. This can also be referred to as adding a marker to the measurement.

For example, in a traffic noise measurement, a bus passing may be identified by the digit "1", while trucks may be identified by "2", unexpected vehicles by "3" etc. In the profile display the markers appear as dots or lines below the graph. If you move the time cursor onto such a dot, the marker type (i.e. its number) will appear in the display.

During a measurement, adding any of the markers 1, 2 and 3 will assign the corresponding marker number to the current period only. Adding marker number 4, however, will assign this marker to the current period plus all consecutive periods until the marker again is deactivated. A typical application for marker 4 is to denote intervals of particular interest.

## Recording the sound

The instrument may be set up to record the sound during a measurement facilitating easy identification of a noise source. The start of the recording may be triggered by the noise event, an external command or started by pressing the **RECORD** button.

Different formats for the recording may be selected to balance the requirements to signal quality and memory usage.

## Excellent for noise monitoring

With the Nor140 you are able to do nearly all types of noise measurements – community noise, industrial hygiene, product control, noise mapping and more.

But, you don't need to attend the measurement sessions all the time. In fact, the Nor140 is able to do a lot on its own.

The measurement time can be preset to e.g. 30 minutes or an hour and the instrument put in a mode where it measures and stores the results, then starts measuring again, stores the results, starts measuring again and so on. Each measurement will be stored in a separate file, but all files are stored in the same directory, which has the name of today's date.

In this way the instrument will measure the periods you need. And if this store and go feature (which is standard) is combined with the optional time profile each measurement will provide global data and a time profile with a resolution specified by you!

Of course, the instrument will spend a little time storing the data (housekeeping). Therefore, if you start the session with hourly measurements exactly on the hour, long "store and go" sessions will – after a while – experience a small, but significant time shift, so that each period no longer starts exactly on the hour.

Enter *synchro mode*. This feature (standard in all models) stops the measurement on the hour and restart the next measurement a couple of seconds later to provide time for storage. By sacrificing a little at the start of a measurement, the synchronisation with the time of day is retained - a feature important to many of our customers.

## The principle of optional extensions

The capabilities and setup options of your Nor140 will depend on which of the available extensions it has been equipped with.

Extensions are modules – made as software, in the instrument or e.g. as software for your PC – available for your Nor140. Norsonic extensions are always optional and hence often referred to as options. In this way you do not have to pay for features you're not going to use.

However, you may find that your tasks are expanding into new areas of acoustics as time goes by. Therefore a typical Norsonic extension will be available for installation as retrofit.

The optional extensions may enhance the operation of the instrument considerably. Normally these types of options are called modes of operation. Such extensions may be transferring the instrument to an FFT-analyser, an analyser for speech transmission index, or a building acoustic analyser for the measurement of sound insulation including measurement of the reverberation time.

## Transducers

Nor140 is normally equipped with microphone Nor1225 and preamplifier Nor1209. Other types of transducers may be connected to the input socket – directly or by suitable interface and/or power supply. Pre-polarised

microphones may be used with the normal preamplifier by switching the polarisation voltage off. The instrument may supply current for 1IEPE-type of transducers. Adaptors from BNC to the input socket are available.

## Check which extensions are installed

Unless you are certain about the extensions installed in your Nor140, we recommend that you spend a little time looking into the matter.

**The extension menu.** Turn on the instrument, or if it is already on, press **MODE > 1** to make sure you are in normal operating mode. Then press **SETUP > 1 > 0**, although you won't find the 0 listed as an option in the Instrument setup menu.

The menu contains a unique ID code which identifies the very individual instrument whose menu you're looking at. In addition, the menu contains three codes. These codes enable the extensions activated for this instrument. The codes take the Id number into account and are valid for this individual instrument only.

- To leave the menu without restarting, press **EXIT**.
- To leave the menu press **ENTER**. Note that the instrument will restart as a consequence of this.



**Note!** The codes are unique for each instrument and will not work in other instruments. Do not change these codes as you will then lose the optional extensions installed and activated!

## Workload

Dependent of the options installed, the Nor140 instrument has the ability to measure a large number of different functions in addition to sound recording. The selection of functions is made by the user through the set-up menu system. A large number of selected functions combined with very short measurement periods and sound recording, may give a workload in excess of the capacity for the signal processor. Other factors that may influence is the speed of the SD-card and communication with USB or RS232 port.

If this appears the work overload is given by a warning message on the screen, and in the form of a **W** in the marker field in the display. A marker **W** is inserted in the time profile.

In case of a work overload the processor disables then the audio recording. As soon as the situation is normalized, the audio recording will be enabled again, and a message; "Audio recording enabled again" will be displayed.

If you get a work overload condition, please consider to alter your settings. The workload is a combination of your settings; hence, the user must define what settings that is most important and what that can be changed in order to lower the workload. We recommend verifying the settings of the following parameters (in priority order):

<sup>1</sup> IEPE – Integral Electronics Piezoelectric is the generic term for transducers (accelerometers and microphone preamplifiers) using constant current supply for the build-in electronics in the transducer. Norsonic has chosen to use this abbreviation in our literature and products. Other abbreviation for the same is ICP®, DeltaTron®, ISOTRON®, CCLD, PIEZOTRON® and CCP.

- Audio recording resolution and speed.
- Pretrigger on the audio recording. If possible, set it equal to or lower than 5 sec. Above 5 seconds, the pretrigger goes into another mode, where the workload is the same as if a continuously audio recording was performed.
- Trigger level of the audio recording. Try to avoid a level where your trigger is about equal to the noise level, then the trigger will go on/off very rapidly, causing an increase in the workload
- Time profile resolution. A time profile of high resolution (less than 500ms) in combination with the above points may cause a workload.
- Number of parameters' that is logged in the time profile.



**The options available.** The below list was complete and exhaustive by the time of printing of this User Guide. However, constant improvements will normally result in new extensions becoming available on a regular basis. Check with your local Norsonic distributor or the factory for an update on this matter.

- Option 0  $L_{Tmax5}$ ,  $L_{eq}$  and  $L_{eq}$  measurements according to German Standards (DIN 45 657)
- Option 1 1/1-octave real-time filters 0,5 - 16 000 Hz
- Option 2 Reference spectrum comparison (require option 1)
- Option 3 1/3-octave filter bands 0,4 - 20 000 Hz (require Option 1)
- Option 4 Statistical calculations
- Option 5 Parallel F, S, I time constants
- Option 6 Basic time profile mode
- Option 7 Enhanced time profile mode (require Option 6)
- Option 8 Sound recording (require Option 6)
- Option 9 Reverberation time calculation (require Option 1)
- Option 10 Internal noise generator with white and pink noise (signal cables not included)
- Option 11 Complete building acoustic mode in accordance with ISO-10052 and ISO-140 series and sound insulation indexes calculated according to ISO-717/1 and ISO-7171/2 (require options; 1, 3, 9 and 10)
- Option 12 Swept-Sine remote measurement mode (require option 11 and Nor1028 NorBuild software on PC)
- Option 13 Speech Transmission Index mode. Calculates the STIPA-value according to IEC60268-16. Incl. CD with excitation signal (Nor1034) (require option 1)
- Option 14 FFT-mode
- Option 15 **Survey** sound power mode for L<sub>wA</sub> measurements according to ISO3746
- Option 16 Trigger for global measurement based on clock, threshold and external signal
- Option 17 Audiometer calibration mode
- Option 18 Extended measurement range with the normal microphone (150 dB peak) including self noise compensation
- Option 19 Extended noise monitoring features such as repeatable read-out

# Taking a closer look at the instrument

You may have to assemble the instrument the first time you use it. Be sure to take utmost care when mounting the microphone cartridge onto the preamplifier.

Always keep the preamplifier disconnected whenever you are screwing the cartridge onto the preamplifier and screw only finger tight!

The instrument is powered from four AA size batteries which are inserted as shown below. If you use rechargeable batteries, these will not be recharged if you connect the Nor140 to an external power supply.

---

Example of batteries inserted correctly



## Switching ON/OFF

The instrument is toggled ON/OFF by pressing the right, lower key. Note that the key has to be pressed down for more than one second for switching the instrument OFF.

## On the use of batteries

The Nor140 comes with four AA batteries (1.5V each). Battery lifetime is typically 8–12 hours (depends on measurement mode and brand of batteries). If you switch to lithium batteries the life time will increase to 15–20 hours. The use of alkaline or lithium batteries is strongly recommended to avoid leakage.

Rechargeable batteries may also be used, but with reduced operating time. Connecting an external DC-source (11–16V) to the instrument will not charge rechargeable batteries, but power the instrument *in lieu* of the internal batteries.

The internal calendar/clock is powered by the normal batteries even when the instrument is switched off. A charged capacitor supply the needed current during the time for changing batteries.

Data is stored in a non-volatile memory and need no power for retaining the information.



**No recharging.** Connecting an external DC-source (11–15V) to the instrument, will not charge rechargeable batteries, but power the instrument in lieu of the internal batteries.

### Battery voltage

Battery voltage is presented graphically as  $f(t)$ . Press the **BATT** key to produce this display and press again to exit the display.

The external supply voltage is shown when connected, else battery voltage

Combined battery voltage as an  $f(t)$

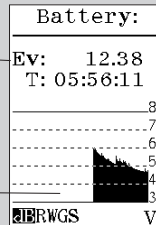

Time elapsed since battery replacement

## Low Voltage Situations

When the combined battery voltage drops below 3.9V, a battery low indicator appears in the display and the instrument will start to shut itself off. Any ongoing measurement will be terminated and stored in a directory called **BATLOW**. Memory contents are retained without the use of electrical power (flash memory). Upon installing fresh batteries, the instrument will at start-up ask the operator for the confirmation to store the previous measurement in the normal measurement directory.

If the instrument is connected to an external DC-source, the external-source-voltage will be displayed (EV). Should the external power fail during a measurement, without any internal batteries installed (or the installed batteries have no power left), the instrument will be turned off immediately without

storing the ongoing measurement. However, as the instrument automatically make a backup storage every 2 minutes, the last file stored will include the correct results except for maximum the 2 last minutes prior to the power failure. Upon return of the external power, the instrument will automatically start to measure as if the **START** key had been pressed.

If powered from internal batteries and left unattended and unoperated, the Nor140 will switch itself off after ten minutes. However, this does not apply if the instrument is measuring (including being paused during a measurement) nor when powered from an external source. The automatic switch off feature may, however, be disabled if required for long-term monitoring purposes. Press **SETUP > 1 (Instr.) > 9 (Misc.par.) > 9 (PowDown)**, and use the **INC** and **DEC** to alter the power off field from **ENABLED** to **DISABLED**.

This feature may be turned off in **SETUP 1 > 9 > 9** and alter the **START** field from **ENABLED** to **DISABLED**. This field is by default set to **ENABLED**. It may be disabled if the user want to monitor it and when the power to the instrument is turned off / tampered.

### Polarisation voltage

The polarisation voltage setting menu opens up for the use of pre-polarised microphone cartridges.

Pol.volt.:

**ON**  
OFF





A prepolarised microphone cartridge will normally exhibit reduced sensitivity when exposed to polarisation voltage. It will regain its initial sensitivity shortly after the polarisation voltage is no longer applied. A conventional cartridge will appear “dead” until after the polarisation voltage is switched ON and then it will work OK.

The above applies to all microphone cartridges supplied by Norsonic. However, a universal guarantee for all brands cannot be guaranteed. Norsonic is not liable for consequential damages following incorrect setting of polarisation voltage.



### **Navigating in the menus.**

Observe the following general guidelines applicable to every Nor140 menu:

- To navigate between editable parameter fields in the menu, use the *CURSOR* keys
- The editable field currently selected is shown inverted (white text on black background)
- Use the **INC** and **DEC** keys to increment or decrement the current setting of the parameter. Alternatively use the keypad to key in the required value, whenever applicable. The # sign will appear in the lower line of the display whenever the instrument accepts numerical inputs
- If you use the *NUMERICAL KEYPAD*, be sure to press **ENTER** before moving to the next field to alter. This is not needed when you use the **INC** and **DEC** keys. **E** is shown on lower line as a prompt.
- To leave the menu putting changes into effect press **ENTER**.
- There is no *CANCEL* function available, so complete the action. Re-enter if you make a mistake.



## Marks on the lower line of the display

You may find the following marks on the lower line:

- dB** The signal strength is indicated as a level in decibel. The reference level is normally 20  $\mu$ Pa for sound pressure levels.
- EU** Engineering unit: The signal strength is indicated in a generic linear unit. The actual unit could be voltage referring to the voltage on the input terminal or ms-2 if an accelerometer is connected to the input.
- #** Num al keyboard. The number printed on the keys are entered if you press one of the keys on the keyboard
- E** A numeric value has been entered. The instrument expects that you press **ENTER** to confirm the number.
- N/H** Indicates Normal or High measurement range. (Polarization voltage dependant.)
- ?** A key is pressed that the instrument does not understand.

Additionally there are marks indicating the applied corrections found on the lower line of the display:

- R** Random incidence correction ON
- W** Wind screen correction ON
- G** Preamplifier correction ON
- S** Self-noise correction ON
- E** Polarization voltage off - Electret microphone

**Clock**

The date and time setting. Press **SETUP > 1 (Instr.) > 3 (Clock)** to produce this dialogue box.

Clock:
Y : M : D 06:08:24
H : M : S 13:03:16
Set clock
RWGS #

## The input menu

Nor140 supports various sensors. The default is the supplied microphone and preamplifier combination Nor1225/1209. In the input menu, **SETUP > 1** (Instr. Menu) **> 4** (Input), you may change the input source to the following alternatives:

- Standard – Default setting. This setting supports the normal preamplifier Nor1209 and the microphone Nor1225. Use this setting for all other types of microphones that requires external 200V polarization voltage. If the unit is supplied with Nor1227 or if you are using other types of pre-polarized microphones (also called self-polarized microphones) go to the polarization voltage field (Pol.volt) and turn this to OFF.
- IEPE – In this mode the instrument supply a constant current of 3mA on pin 4 on the Lemo microphone socket. This is used when connecting IEPE accelerometers or preamplifiers with self polarized microphones. All preamplifier corrections and other corrections like windscreen, random field etc. are turned off.
- Line – This mode is used for connecting an electrical signal directly to the instrument. All preamplifier corrections and other corrections like windscreen, random field etc. are turned off.
- 1214/1216/1217 Vertical – vertical direction. This mode is used when connecting any of the outdoor microphones Nor1214, Nor1216 or Nor1217 with the sound propagating in the vertical direction, typical used when measuring air craft noise.

If you use a Nor1225 set the pol volt field below to ON. Set it to OFF if you use a Nor1227, prepolarised microphone.

- 1214/1216/1217 – Horizontal direction. This mode is used when connecting any of the outdoor microphones Nor1214, Nor1216 or Nor1217 with the sound propagating in the horizontal direction. Typically used when measuring community noise, like traffic or industry noise.

If you use a Nor1225 set the pol volt field below to ON. Set it to OFF if you use a Nor1227, prepolarised microphone.

If STANDARD or any of the Nor1214/Nor1216/Nor1217 is selected, two sub menus are possible to access.

1. Level range. In this menu you may choose between NORMAL and HIGH measurement range. Detailed description is found in *Compensation and correction*. This feature requires option 18 – extended measurement range
2. Correction. Detailed description in found in *Compensation and correction*.

## Selecting language

The Nor140 supports several languages. The language is selected in **SETUP > 1** (Instr. Menu) **> 2** (IO/Print).

The front panel keys of the Nor140

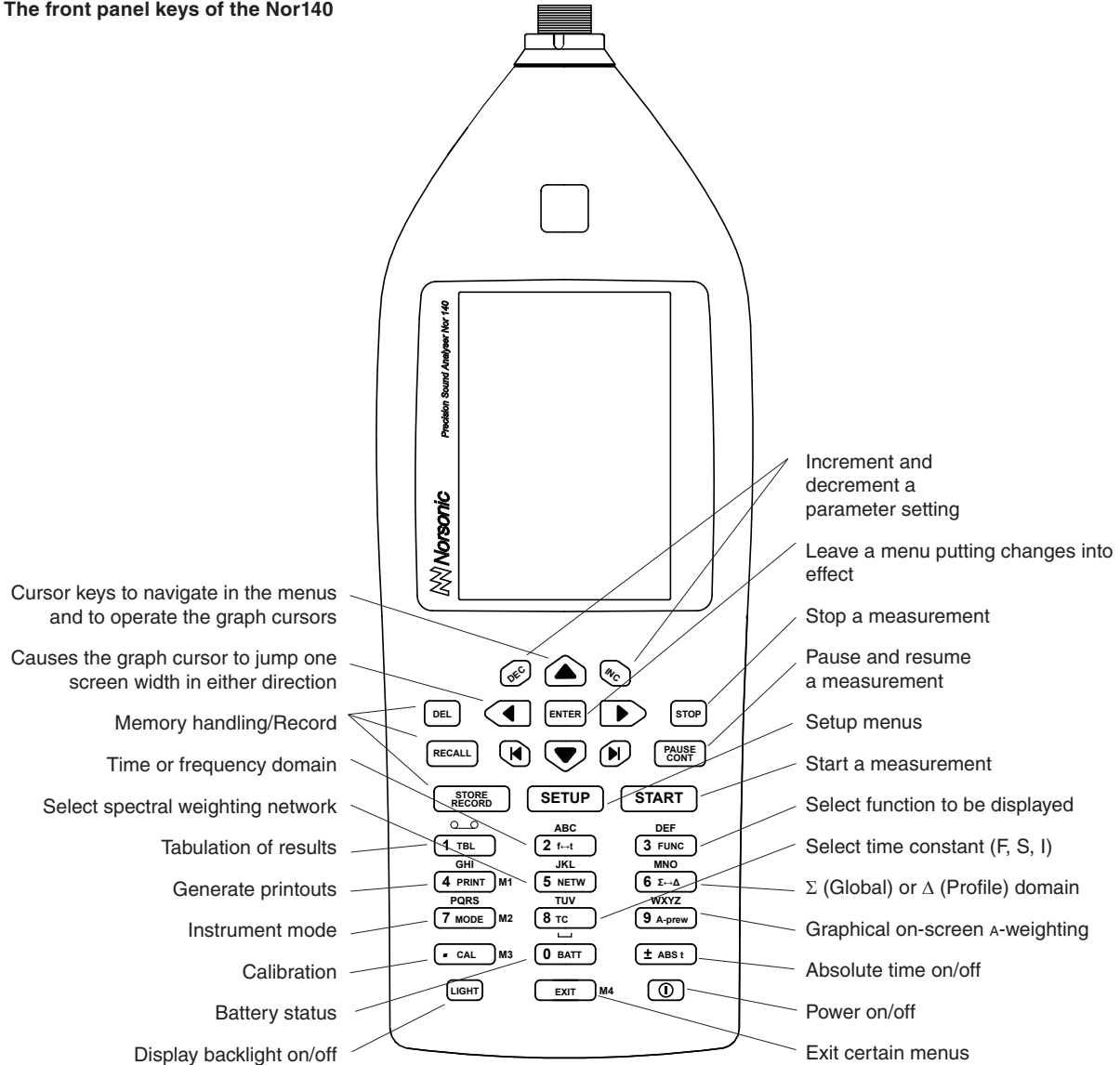

# Calibrating the instrument

Calibration is the normal way of ensuring that the sound level meter measures the level with sufficient accuracy. To calibrate we need a sound calibrator.

The use of sound calibrators dates back to the days when it was easier to design a stable sound calibrator than a stable sound level meter. Today, sound measuring instruments are, in general, as stable as sound calibrators. However, measuring microphones are very delicate devices designed to fulfil very rigid specifications. This makes them vulnerable and subject to damage unless proper care is taken.

One may therefore say that a sound calibrator is just as much a verification of proper operation as it is a device of adjusting the sensitivity of sound measuring instruments.

The Nor140 is calibrated by means of menus and key pushes – there is no need for a screwdriver to turn a potentiometer!

## When to calibrate

Calibration of the Nor140 should preferably take place before a measurement session is commenced, or whenever required by applicable standards. If you know the microphone cartridge sensitivity, you may key this in using the numerical keypad. However, doing so will never replace calibration with a sound

calibrator, as the sensitivity adjustment procedure will be unable to reveal possible microphone, preamplifier or extension cable malfunctions.

## No need to adjust the full scale setting

Since the Nor140 has a 120 dB dynamic range (10–130 dB SPL), the 80 dB bar graph range is a display limitation only. Hence, you won't have to bother with setting the full scale before you enter the calibration menu.

Furthermore, since the Nor140 automatically enters C-weighted mode, you won't have to bother with the calibrator frequency either.

However, you may have to adjust the display top scale setting to see the top of the bar graph. Use the **INC** and **DEC** keys for this before you enter the calibration menu.

## Carrying out the calibration

You will need a sound calibrator of sufficient accuracy, i.e. a class 1 sound calibrator as defined by the IEC 60942 standard such as the Norsonic sound calibrator Nor1251 or Nor1253. Do as follows:

**1 Mount the calibrator onto the sound level meter.**

Mount the sound calibrator onto the microphone as shown to the right. Switch on the sound calibrator and wait until the level has stabilised. Information on how long time this will take should be available from the documentation accompanying your sound calibrator.

**2 Enter calibration mode.** Press the **CAL** key to gain access to the Calibration menu. The display will typically look as shown to the right. **Note:** Never calibrate the instrument before three minutes after switching the instrument on.

**3 Know the output level of your sound calibrator.**

Some sound calibrators have an output level of 94 dB, while others (like the Nor1251 which is used in the example to the right) have an output level of 114 dB. Some have an output of 124 dB (like the Nor1253). Unless you know the output level of your sound calibrator you won't be able to know what level the measuring instrument is supposed to show. The output level is normally printed on the sound calibrator or stated in its accompanying user documentation.

**4 Free-field microphones require lower settings.**

Be aware of the fact that instruments using free-field microphones shall be adjusted to a value slightly lower than the output level of the sound calibrator. For a half-inch cartridge this will typically amount to 0.2 dB lower for calibrators producing a 1000 Hz calibration signal (e.g. the sound level meter should then be set to 113.8 dB when using a 114 dB @ 1000 Hz sound calibrator) Other frequencies will require different correction values, see the Field calibration side bar (overleaf) for more on this.

**5 Set the sensitivity.** To set the sensitivity correctly use the **INC** and **DEC** keys while at the same time watching the level read-out. Alternatively, you may key in the required sensitivity using the numerical keypad. Once the correct level reading is established press enter to leave the menu.

The sound calibrator should be mounted onto the microphone as shown here.

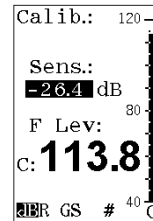

Use these keys to adjust the sensitivity...



or, use the numerical keypad to key in the sensitivity



**Field calibration.** The recommended sound calibrator for verification of the sound level meter Nor140 is the Norsonic Nor1251 with a nominal sound pressure level of 114,0dB @ 1kHz. In order to compensate for diffraction effects around the microphone, we recommend adjusting the sound level meter to indicate 113,8dB (random correction off). If random is on, adjust to 114.0 dB. If other types of calibrators are to be used for the calibration, we recommend adjusting the sound level meter to indicate the following levels referred to the sound pressure level acting on the microphone's diaphragm (diffuse correction off):

f [Hz]	125	250	1000	4000	8000
Corr. [dB]	0.0	0.0	-0.2	-0.8	-2.8

The diffuse correction is activated and deactivated in the Corrections menu.

Press **SETUP > 1** (instr.) **> 4** (Input) **> 2** (Correct.).

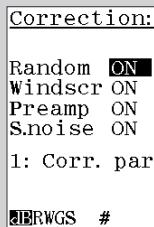

Navigate in the menu using the arrow keys and use **INC** or **DEC** to activate/deactivate the Random setting. Activated Random setting is indicated by an R in the lower line of the display.



You may either set the sensitivity to the combined value for the microphone and the microphone preamplifier, or split the sensitivity in one for the microphone and one for the preamplifier.  
*See Technical specifications.*



The dB value corresponds to the sensitivity level of the microphone cartridge; dB relative to 1 volt/pascal, e.g. 50 mV/Pa corresponds to -26,0 dB. The instrument may also be set up to compensate for the attenuation taking place in the preamplifier, which normally amounts to about 0,7 dB – see Preamplifier attenuation in the Technical specifications for more on this.

This value is factory set and should normally not be changed unless you permanently change to a microphone cartridge with another cartridge capacity.



**Notes when calibrating outdoor microphone Nor1214, Nor1216 or Nor1217**

Please note that the frequency correction is turned off, when entering into the calibration menu. Perform calibration and calibrate the microphone as a normal free field microphone. I.E. -0.2dB if using a 1000Hz calibrator. When leaving the calibration menu, you will observe that the level measured with the calibrator on, is different from what obtained in the calibration mode. This is correct, and is due to the frequency correction added. If Horizontal position is selected the signal will be about 0.1dB higher than the calibrated signal, in vertical position the signal will be 0.3dB lower than the calibrated level.



**Microphone check.** For long term monitoring purposes, it is often handy to be able to check the functionality of the measurement system along the signal line from microphone/preamplifier until the display of the instrument without the use of an external calibrator. The Nor140 has a build-in Mic.Check feature that allows this (also called SysCheck).

Pin 1 on the microphone input socket is able to supply a known voltage signal to the Norsonic Preamplifier Nor1209 (see Chapter 28 for details). By enabling this constant voltage signal, the entire measurement chain including the microphone is tested, and the display will show the corresponding measured value in dB. Hence, if this value is constant from the previous check, it is highly likely that the overall functionality of the measurement chain is constant.

The procedure for using this Mic.Check feature is as follows:

1. Perform a normal calibration of the entire instrument by use of an external calibrator (see the previous pages in this Chapter 3 for details)
2. Press the **SETUP** > **1** (Instr.) > **9** (Misc.par.) > **7** (Mic.chk.) key sequence to open the Mic.Check menu. Place the cursor on the upper field, and turn the feature "ON" by use of the **INC** or **DEC** keys.
3. If an external device simultaneously should be controlled by the Mic.Check feature, turn the DO-3 (Digital Output line 3) "ON" in the lower field instead. This is the case when using outdoor microphone Nor1210 A or C.
4. Exit from the Mic.Check menu by pushing the **ENTER** key four times.
5. By pushing the **CAL** key, the Mic.Check signal is activated. The measured signal is then read in the display. The level will be dependent of the actual previous sensitivity calibration as well as the individual preamplifier and microphone in use. Normally, using the Norsonic Preamplifier Nor1209 and Microphone Nor1225, the level will be approx. 90 dB with a 1-2 dB variation from instrument to instrument.
6. Push the **CAL** key again to turn off the Mic.Check feature, and make the normal measurements.
7. At any time, both during and after a measurement (i.e. Running or Ended/Stopped status), the Mic.Check feature may be turned on again. The level should display the same value as read in point 4 above.

**NOTE/CAUTION:** Always turn off the Mic.Check when calibrating the system with an acoustical calibrator. If not you will add the acoustical and the Mic.Check tone together resulting in a wrong calibration value, often observed as unstable calibration value.

**NOTE:** If the Mic.Check feature is used during a running measurement, the measurement will be influenced by the inserted voltage signal. Hence, this part of the measurement should be excluded from the results in the post processing of the measurement data in order to give the correct level on any measured sound source. Please note that the Mic.Check feature requires the use of the Norsonic Preamplifier Nor1209. All types of measurement microphones can be used, both polarised and prepolarised. The Mic.Check level is dependant on the microphones cartridge capacitance. Hence, a 1/4" microphone will return a much lower signal level than 90dB. The Mic.Check feature works also with the Norsonic Dehumidifier Nor1284 and Nor1285 mounted.



# Simple sound measurements

The Nor140 may still be used as a simple sound level meter. The only thing you really need to set up is the measurement duration, which at least must be set up to match the amount of time you intend to be measuring. If it is set to a longer time, this will constitute no problem – just press the **STOP** key when you want to terminate an ongoing measurement.

However, you should consider the settings of the time constant and the spectral weighting (C- or Z-weighting, see *Setting C or Z as spectral weighting network* for more on this) also, but once they are set, the instrument will remember these until they are changed to something else.

## Setting the duration

Your instrument may, or may not be equipped with the optional extension 6, which is the time profile logging. This affects the look of the measurement duration set-up menu. To read more about optional extensions see The principle of the optional extensions.

How the menu looks with and without the optional extension 6 installed is shown overleaf.



**Navigating in the menus.** Observe the following general guidelines applicable to every Nor140 menu:

- To navigate between editable parameter fields in the menu, use the cursor keys
- The editable field currently selected is shown inverted (white text on black background)
- Use the **INC** and **DEC** keys to increment or decrement the current setting of the parameter. Alternatively use the keypad to key in the required value, whenever applicable. The # sign will appear in the lower line of the display whenever the instrument accepts numerical inputs
- If you use the numerical keypad, be sure to press **ENTER** before moving to the next field to alter. This is not needed when you use the **INC** and **DEC** keys.
- To leave the menu putting changes into effect press **ENTER**.
- There is no cancel function available.

### Measurement duration setup menu

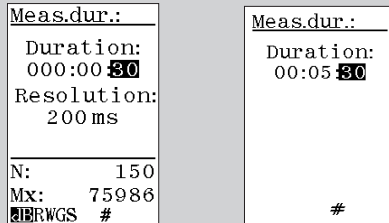

Measurement duration setup menu when time profile option is installed (left), and when it's not (right).



**Missing percentiles?** There may be percentiles that fail to produce values in the table. This is because you have not measured for a time long enough to provide the necessary number of samples.

Statistical sampling – which should not be confused with the sampling of the analogue-to-digital conversion – takes place 10 times a second. For comparison, the sampling of the analogue-to-digital conversion runs at 48 kHz!

Since the statistical sampling takes place 10 times a second, it will take 10 seconds to produce 100 samples. You will need at least 100 samples to be able to calculate the 1% percentile.

Likewise, for the 0,1% percentile the minimum time required will be 100 seconds. Measurements whose duration are shorter than these minimum limits will not produce percentile values for all possible settings of the percentiles.

### To produce the measurement duration setup menu:

- Press **SETUP > 2**. To leave the menu press the enter key.

### Statistics

Even if your instrument is equipped with the optional extension 4 – statistics, the percentiles table will fail to produce values for all percentile settings unless the measurement duration is sufficiently long – see the *Missing percentiles* side bar below left for more on this.

### The sound level meter display

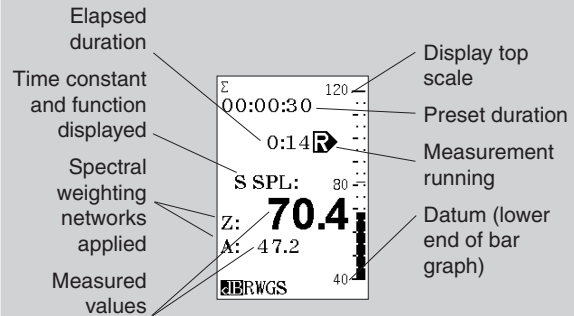

### Going to measure very high levels?

As an optional extension the Nor140 is able to measure very high sound pressure levels without changing the microphone cartridge – see *High levels in the Technical specifications for details*.

## Instruments with time profile installed

If your instrument has the time profile installed and you don't require it, you should set the resolution to the same value as the duration to keep the instrument from logging the level as a function of time.

### Setting the time constant

If your instrument is *not* equipped with the optional extension 5 – parallel time constants, you may want to specify the time constant to be used in the measurement. The time constant is used for the SPL, the  $L_{MAX}$  and the  $L_{MIN}$  measurements, but neither the  $L_{eq}$ , the  $L_E$  nor the  $L_{PEAK}$  makes use of it. The exceedance level,  $L_n$ , always apply the F time weighting and is independent of the setting.

To set the time constant press the **TC** key until the required time constant appears in the display. To see this, be sure to operate the **FUNC** key until any of the functions SPL, the  $L_{MAX}$  or the  $L_{MIN}$  appears in the display first.

If your unit is equipped with multiple time constants, you need not bother with this.

## Instruments with multiple time constants

Instruments equipped with multiple time constants will always employ all three time constants (F, S and I) for all measurements. The time constants apply to the SPL, the  $L_{MAX}$  and the  $L_{MIN}$  functions.  $L_{eq}$ ,  $L_{PEAK}$  and  $L_E$  do not make use of time constants. Units configured for German-speaking markets will also measure the  $L_{eq}$ .

The presence of multiple time constants eliminates the need for setup of the time constant.

## Multiple time constants and statistics

Observe that the statistics buffers (optional extension) will be based on sampling using time constant F. This cannot be changed by the user.

## C or Z as spectral weighting network

The Nor140 has three spectral weighting functions in addition to the filter bands. These are A-weighting and C- or Z-weighting. The Z-weighting is a replacement for the previous Flat or Linear spectral weighting functions. A problem when dealing with the Flat and Linear functions has been that none of them are properly defined in any standard.

The Z spectral weighting circuitry is flat within at least 16Hz to 16kHz (in the Nor140 it extends far beyond that) and is defined in the International standard IEC61672-1.

The Nor140 can make use of two of the three spectral weighting functions simultaneously – viz. A-weighting and Z- or C-weighting.

### To specify whether to use Z- or C-weighting:

- Press **SETUP > 1** (instrument) **> 5** (2nd netw) and navigate in the menu as usual. Press **ENTER** twice for return to the measurement.



Please note that for the Z network there is a possibility to extend the frequency range down to 0.4 Hz. This is not possible for the C network as this network cuts lower frequencies anyhow.

## Making a measurement

### To start a measurement:

- Press the **START** key. The **R** in the display indicates that a measurement is running.

### To temporarily halt an ongoing measurement:

- Press the **PAUSE/CONT** key.

### To resume a paused measurement:

- Press the **PAUSE/CONT** key again. Upon resuming the instrument will go on measuring until the total measurement time elapsed equals the preset duration. Observe that data acquired immediately preceding the pause may be erased because of the back-erase function (see below).

### To terminate an ongoing measurement:

- Press the **STOP** key.



#### What can be done to the measured data?

Data acquired are available for inspection, during or after a measurement.

You may:

- Display the functions measured
- Display the result table
- Change the spectral weighting function between **A**- and **C**- or **Z**-weighting
- Display the eight percentiles and set one of them as you like
- Store them for future use

### To resume a terminated measurement:

- To resume a terminated measurement press the **PAUSE/CONT** key. Upon resuming the instrument will go on measuring until the total measurement time elapsed equals the preset duration. When a terminated measurement is resumed, the back-erase feature (see below) will *not* be activated.

### To switch between absolute and relative time:

- To switch between time elapsed since start of measurement (relative time) and date + time of day (absolute time), use the **ABS t** key.

### To display other functions measured:

- Use the **FUNC** key. For the German-speaking markets these functions will include  $L_{eq}$  and  $T_{Max5}$ .

### To adjust the display top scale:

- If the bar graph fails to match the level measured use the **INC** and **DEC** keys to alter the display top scale setting.

### To switch between the spectral weighting functions:

- Use the **NETW** key to switch between A-weighted and C- or Z-weighted or the A-weighted and the C-A (Z-A) weighted functions.

### To produce the results in tabulated form:

- Press **TBL** to produce a result table. See *Displaying the result tables* for more on this.



Pausing deletes up to 20 seconds of the last data. If you don't want this, use **STOP** and then **PAUSE/CONT** to continue the measurement, or set the back erase time to 0 in the Back erase setup menu. **SETUP 1 > 9 > 8..**

## Resuming an ended measurement

Assume that you have set up the instrument to measure for 5 minutes and that you start the measurement. After 5 minutes the measurement will end since the measurement time elapsed equals the preset duration. The measurement has now ended successfully.

If you now press the **PAUSE/CONT** key, the instrument will resume the measurement and go on measuring for another 5 minutes so that the total measurement time assumes 10 minutes, i.e. twice the initial setting. If you do this again, the total measurement time will be 15 minutes, i.e. three times the initial setting and so on. This feature is useful for obtaining the averaged values from different positions of measurement.

This way of prolonging a measurement will not activate the back-erase feature (see below for more on this).

## The back-erase function

The Back-erase function allows you to halt an ongoing measurement and erase the last part of it, before you resume the measurement again. This function is particularly useful to exclude undesirable noise events. The Back-erase time can be set to any value between 0 and 20 seconds. Press **SETUP 1 > 9 > 8** to access the menu.

When you press the **PAUSE/CONT** key during an ongoing measurement, the instrument will temporarily

halt the measurement until the **PAUS/CONT** key is pressed again. Depending on the set back erase time, the last acquired data will be erased

If the measurement has been running for less than the set back-erase time when you press **PAUSE/CONT** key, the entire measurement will be erased upon resuming the measurement. If less than the specified back-erase time has elapsed since you resumed a paused measurement, only the last part of the measurement since the last resume will be erased. Data acquired earlier are assumed to be accepted by you.

The measurement time elapsed counter will be updated to reflect the back erase time. The statistics buffers (optional extension) as well as all other measured parameters will be updated accordingly.

## Displaying the functions measured

The instrument measures the SPL,  $L_{MAX}$ ,  $L_{MIN}$ ,  $L_{eq}$ ,  $L_E$  and the  $L_{PEAK}$ . Note that the SPL,  $L_{MAX}$  and  $L_{MIN}$  are all measured with the selected time constant while the rest do not make use of the time constant at all.

### The functions are available sequentially

To display a certain function, press the **FUNC** key repeatedly until the function appears. The sequence is as follows:

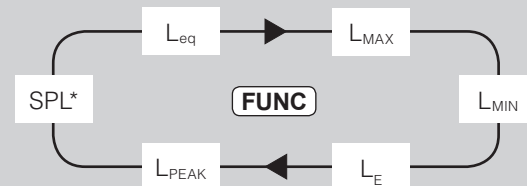

\*Accessible during measurement only – not after!

### Units configured for the German-speaking markets

If also equipped with  $L_{eq}$  and  $T_{Max5}$ , the sequence is as follows (press func key repeatedly):

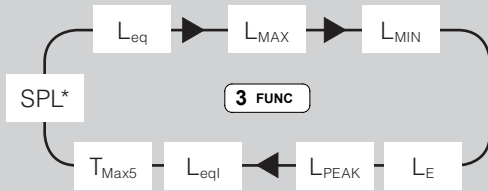

### Units with multiple time constants

Units with multiple time constants will measure the  $L_{MAX}$  and  $L_{MIN}$  with all three time constants (F, S, I) employed simultaneously.

During – but not after – a measurement, the SPL will also be available for display.

To view one of the functions as measured with another time constant, use the **FUNC** key to produce the function and then press the **TC** key once or twice.

During measurements the SPL value is displayed. Once the measurement is over, the SPL becomes meaningless. A single SPL value cannot be used to characterise the measurement unless it represents some kind of maximum, minimum or time integrated average. It is thus not accessible post measurement.

To return to **READY** mode, i.e. how the instrument behaved before the measurement was started, press the **EXIT** key. You will be prompted to store the data or press **EXIT** again. In both cases the instrument will go

back to **READY** mode. The SPL will now be displayed again.

If you choose not to store the data (i.e. you did press **EXIT** a second time) the measured data will be lost beyond retrieval. Storing is dealt with later.

## Displaying the result tables

As an alternative to the above procedures, you may display all the data in a single table. Press the **TBL** key to produce the result table. This feature is available during as well as after a measurement. Do not forget that SPL values are only shown during a measurement – never after the measurement is over (unless SPL is logged as a function of time)!

To produce the table of measured results using the other spectral weighting function press the **NETW** key while in the table.

### The result table

Once you've pressed the **TBL** key, the display will typically look like this:

Measurement time	Σ 0:08 A	Σ 0:05 A	Spectral weighting applied
	Leq : 40.9	Leq : 37.9	
	F Max : 47.6	F Max : 39.5	
	F Min : 36.9	F Min : 37.3	
	LE : 49.4	LE : 44.9	
	Peak: 62.0	Peak: 53.5	
	I Leq : 44.5	I Leq : 46.4	
	F Tmx5: 47.6	F Tmx5: 39.5	
	F SPL : 37.9	F SPL :	
	⏏	⏏	

Measurement is running

Observe that once the measurement is no longer running, no SPL value is available. Units not configured for the German speaking markets will have tables not containing the  $L_{eq}$  ( $L_{eqI}$ ) and  $T_{mx5}$  values.

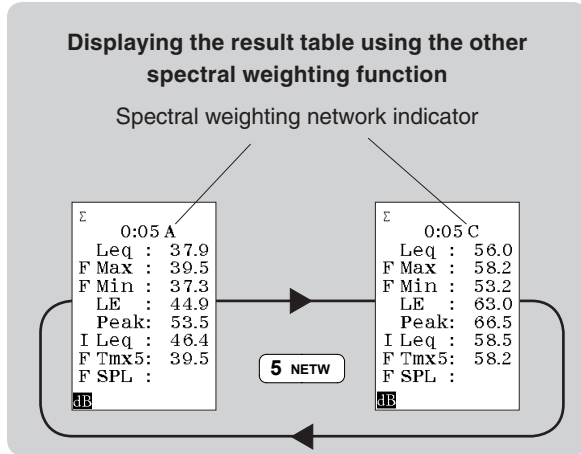

There are two spectral weighting functions available A- and C- or Z-weighting. The latter should be set by you prior to the measurement.

Even before you enter the table you may use the **NETW** key to view the results of applying the two spectral weighting functions.

The actual spectral weighting function used in the table depends on the setting active before the **TBL** key was pressed. At any rate, press **NETW** to toggle between primary and secondary weighting function.

### Statistics – displaying the percentiles

Instruments equipped with the optional extension 4 – statistics – will measure the statistics every time. This cannot be switched off.

The sampling for the statistical calculations is made with F time constant and the class width is 0.2 dB over the entire 130 dB dynamic range – always!

You may think that storing all these data will require a huge memory, and you're absolutely right. Therefore, we

refrain from that, we store just eight percentiles instead. Seven of them are fixed and one is user-editable.

Your user-editable percentile can be set to anything in the range 0.1–99.9 %, both extremes included. The procedure is explained next page.

Data measured, - not recalled - may be subject to changes in the user-defined percentile. This means that you may change the percentile as many times as you want. For stored and later recalled data any changing of the user-editable percentile is no longer possible.

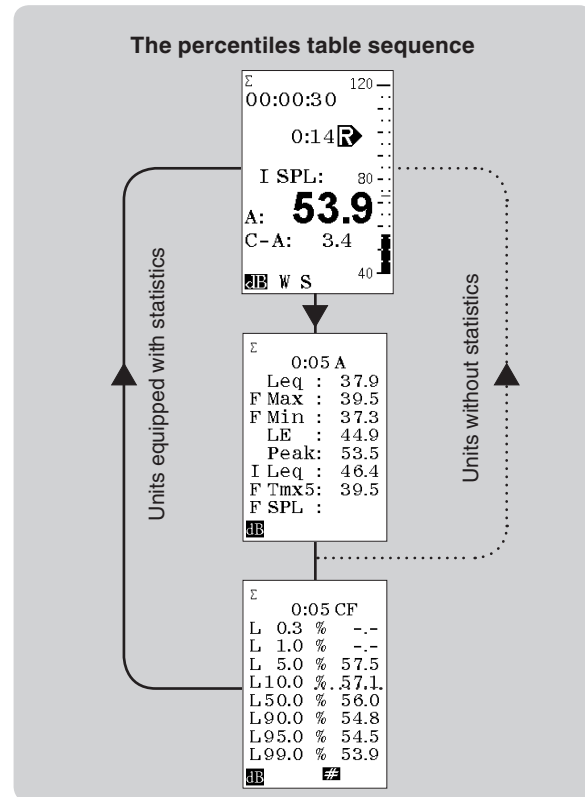

### Editing the user-defined percentile

To enable the editing the instrument must display the percentiles table. In the percentiles table press the **◀** key (the end-left key) to enable this.

Once the percentile field is shown inverted (with white text on black background) the text can be edited using the numerical keypad or **INC** and **DEC**. If you use the numerical keypad you must press **ENTER** to confirm that you have keyed in the new percentile.

To terminate the editing process press the **▶** (end-right key). The corresponding percentile value will now be displayed, given that the measurement duration was long enough to provide a sufficient number of samples.

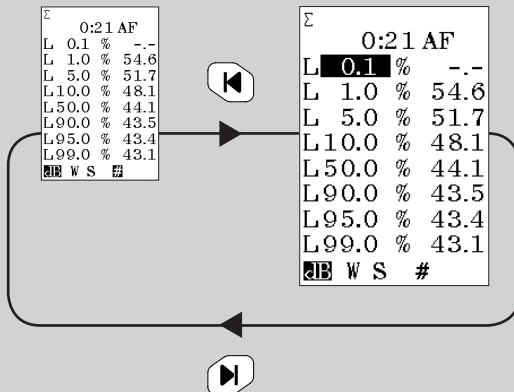

The user-defined setting applies to both spectral weighting settings. The two cannot have individual settings!

### Displaying the percentiles table

To produce the percentiles table press **TBL** to enter the result table and **TBL** again to enter the percentiles table. Units not equipped with the statistical extension will exit the table upon the second push on **TBL** and return to the sound level meter display mode. The sequence is shown in the side bar.

### Storing the acquired data

The Nor140 has a large, non-volatile memory to hold the measurements. The memory structure resembles the memory structure of a personal computer in the sense that both use folders and files. In addition data may be stored on a detachable SD-card.

The structure for storing data is very simple; The folder has the name of today's date and the files are numbered consecutively from 0001 and upwards. Consequently, the maximum number of measurements per day is 9999, but this should be a limitation most people will be able to live with. After all, you are going to look through these files later as well, aren't you?

### Storing the acquired data:

- Press the **STORE/RECORD** key. The display will show the folder and file number.

All aspects of the memory handling are discussed in detail in *Chapter 11- Memory handling*.

### Printing out the results

By connecting a printer to the RS232 interface, the results can be output to a printer. This is treated in detail in *Chapter 13 - Making hardcopies*.



## User defined table

The user may compose a user defined numeric table consisting of just the needed parameters for a given application. A typical task is a table consisting of only LAeq and Peak C. The parameters is selected in **SETUP** > **1** (Instrument menu) > **9** (Misc. parameters) > **1** (User par.). Use **INC** - **DEC** key to select parameters on/off. Use arrow keys to move to the desired field. Use **NETW** key to move between A, C (or Z) and Ln% table values. The table is accessible using the TBL button if you are in the graphical Sound Level Meter display (Not L/t or L/f display). Please note that all the other standard tables accessible from the graphical sound level meter display are replaced by the user defined table. If you need to revert to the standard tables, just enter the user defined table setup and turn off all parameters.

# Frequency analysis

As an optional extension 1, you may have your Nor140 equipped with parallel octave band filters. By adding the optional extension 3, third-octave band filters become available as well. The selectable frequency range, expressed as centre frequencies, is either 8–16 000 Hz or 0,5 - 16 000 Hz for the octave band filters and 6.3–20 000 Hz or 0,4 - 20 000 Hz for the third-octave band filters.

When you make a frequency analysis, this comes in addition to the traditional sound level measurement as described in the chapter *Simple sound measurements*.

## Setting the measurement duration

Your instrument may, or may not be equipped with the optional extension 6, which is the time profile logging. This affects the look of the *Measurement duration setup* menu. To read more about optional extensions see *The principle of the optional extensions*.

How the menu looks with and without the optional extension 6 installed is shown below.

### To produce the measurement duration setup menu:

- Press **SETUP > 2**. To leave the menu press the **ENTER** key.

Instruments without the multispectrum extension (option 8) are not able to capture the spectra as a function of time. However, instruments equipped with the time profile extension – the basic version as well as the enhanced version – may log the A- and C- or Z-weighted levels as functions of time in parallel with the overall frequency analysis described in this chapter.

Details on the logging of the level vs. time can be found in the *Enhanced time profile measurements* and *Basic time profile measurements*.

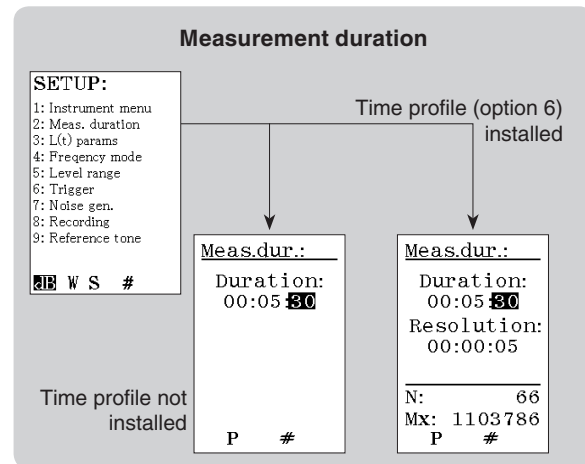

## Statistics

If your instrument is equipped with the optional extension 4 - statistics, the percentiles table will be produced and there will be 8 percentiles for every centre frequency. fail to produce values for all percentile settings unless the measurement duration is sufficiently long – see the *Missing percentiles* side bar in this chapter for more on this.

## Instruments with time profile installed

If your instrument has the time profile option installed, you are able to see the time history for each filter frequency. If you don't require it, you should set the resolution to the same value as the duration to keep the instrument from logging the level as a function of time – like the classic level recorders used to do.

Cf. *Enhanced time profile measurements, Basic time profile measurements and Multispectrum measurements* for details on logging the level vs. time with or without the spectrum as a function of time.

## Consider setting the time constant

If your instrument is not equipped with the optional extension 5 – parallel time constants (see *Units equipped with multiple time constants*), you may want to specify the time constant to be used in the measurement.



Multispectrum is available as long as minimum option 1 and 6 are installed. This is treated in *Multispectrum measurements*.

The time constant is used for the SPL, the  $L_{MAX}$  and the  $L_{MIN}$  measurements, but neither  $L_{eq}$  nor  $L_E$  make use of it.

To set the time constant press the **TC** key until the required time constant appears in the display. To see this, be sure to operate the **FUNC** key until any of the functions SPL, the  $L_{MAX}$  or the  $L_{MIN}$  appears in the display first.

## Setting C or Z as spectral weighting network

The Nor140 has three spectral weighting functions in addition to the filter bands. These are A-weighting and C- or Z-weighting. The Z-weighting is a replacement for the previous Flat or Linear spectral weighting functions.

The Z spectral weighting circuitry is flat within at least 16 Hz to 16 kHz and is defined in the International standard IEC 61672-1.

The Nor140 can make use of two of the three spectral weighting functions simultaneously – viz. A-weighting and Z- or C-weighting.

### To specify whether to use Z- or C-weighting:

- Press **SETUP > 1** (instrument) **> 5** (2nd netw) and navigate in the menu as usual.

The A-weighted value and the C- or Z-weighted value will appear as extra bar graphs to the right of the spectrum in the display.

## Finding the energy level over a part of the frequency range

Sometimes, the result you are looking for is the energy in a specific frequency range, but the total level is disturbed with noise coming from another source. The A, C or Z value is therefore not correct for your application. For such cases there is a special function available.

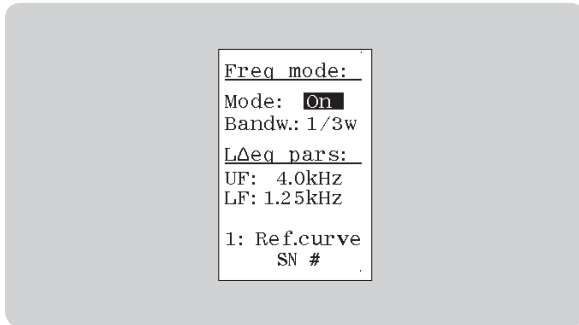

Here you can specify the upper and lower frequency of interest and the calculated Leq value for this frequency range will be displayed in the tabular result picture as LΔeq.

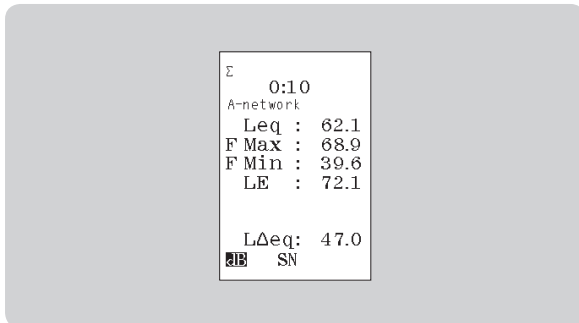

## Activating the frequency mode

In order to enable frequency analysis, the frequency mode must be activated. Turn on the instrument or select **MODE > 1** to make sure you are in Normal operating mode.

### Activating frequency mode:

- Press **SETUP > 4** (Freq mod.) to gain access to the frequency mode menu. Navigate in the menu as usual. Set the bandwidth as required.
- Toggle the mode On or Off by using **INC** or **DEC** buttons
- Select bandwidth by using **INC** or **DEC** buttons:
  - 1/1 w - Octaveband 0,5 - 16 000 Hz
  - 1/1 - Octaveband 8 - 16 000 Hz
  - 1/3 w - 1/3-octaveband 0,4 - 20 000 Hz
  - 1/3 - 1/3-octaveband 6,3 - 20 000 Hz

### Going to measure very high levels?

As an optional extension the Nor140 is able to measure very high sound pressure levels without changing the microphone cartridge – see High levels in the Technical specifications for details.

### Menu for activation of the frequency mode

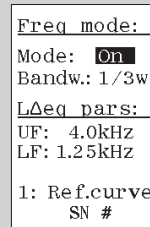

Press **SETUP > 1> 4**  
to produce this menu.



As long as the frequency mode has been activated, frequency analysis will be made during every measurement. This means that the instrument will combine a “traditional” sound level meter measurement and a real time frequency analysis in octaves or third-octaves. Whether the instrument is set to show the spectrum or the classic sound level meter display will not affect the measurement in any way. Likewise, going between the two displays modes during a measurement has no effect on the measurement either.

### Switching to displaying the spectrum

Having activated the frequency mode and left the menu, just press the **f↔t** key to display the level vs. frequency and press again to return to the other display. Since no measurement has been made the only function producing frequency band bar graphs will be the SPL with the selected time constant. If you press the **FUNC** key this will produce empty displays only. If you did, just keep pressing the **FUNC** key until the SPL reappears.

#### Switching between sound level meter display and spectrum display

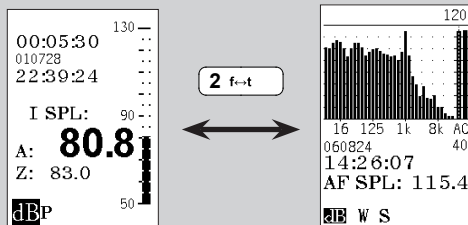

Sound level meter display

Spectrum display

## Making a frequency analysis

### To start a frequency analysis measurement:

- Set the measurement duration.
- Press the **START** key. The R in the display indicates that a measurement is running. The measurement is running and data acquired irrespectively of whether the frequency spectrum is shown or not.

### To temporarily halt an ongoing measurement:

- Press the **PAUSE/CONT** key.

### To resume a paused measurement:

- Press the **PAUSE/CONT** key again. Upon resuming the instrument will go on measuring until the total measurement time elapsed equals the preset duration. Observe that data acquired immediately preceding the pause may be erased because of the back-erase function (see below).

### To terminate an ongoing measurement:

- Press the **STOP** key.

### To resume a terminated measurement:

- To resume a terminated measurement press the **PAUSE/CONT** key. Upon resuming the instrument will go on measuring until the total measurement time elapsed equals the preset duration. When a terminated measurement is resumed, the back-erase feature (see below) will *not* be activated.

### To switch between absolute and relative time:

- To switch between time elapsed since start of measurement (relative time) and date + time of day (absolute time), use the **ABS t** key.

#### To display other functions measured,

- Use the **FUNC** key. For the German-speaking markets these functions will include  $L_{\text{eq}}$  and  $T_{\text{Max5}}$ .

#### To switch between sound level meter display and spectrum display:

- Press the **f↔t** key

#### To make the spectrum appear A-weighted

- Press the **A-prew** key. The display will now appear A-weighted. This is purely a display function and it has no effect on the measured or stored data.
- Use the **◀** and **▶** keys. Use the **◀◀** and **▶▶** keys to move to the lowest and highest frequency band.

#### To adjust the display top scale:

- If the bar graph fails to match the level measured use the **INC** and **DEC** keys to alter the display top scale setting.

#### To produce the results in tabulated form:

- Press **TBL** to produce a result table. Note that different tables will be shown dependant on the state of the instrument. During and after a measurement you may have both spectral values, statistical values and normal result table for the selected frequency band or weighting network. The up and down arrow buttons is used for switching between the frequencies and networks in tabular mode.

### Resuming an ended measurement

Assume that you have set up the instrument to measure for 5 minutes and that you start the measurement. After 5 minutes the measurement will end since the meas-

urement time elapsed equals the preset duration.

The measurement has now ended successfully, as opposed to if you press the stop key to forcefully terminate an ongoing measurement.

If you now press the **PAUSE/CONT** key, the instrument will resume the measurement and go on measuring for another 5 minutes so that the total measurement time assumes 10 minutes, i.e. twice the initial setting. If you do this again, the total measurement time will be 15 minutes, i.e. three times the initial setting and so on.

This way of prolonging a measurement will not activate the back-erase feature.

### The back-erase function

The Back-erase function allows you to halt an ongoing measurement and erase the last part of it, before you resume the measurement again. This function is particularly useful to exclude undesirable noise events. The Back-erase time can be set to any value between 0 and 20 seconds. Press **SETUP 1 > 9 > 8** to access the menu.

When you press the **PAUSE/CONT** key during an ongoing measurement, the instrument will temporarily halt the measurement until the **PAUSE/CONT** key is pressed again. Dependant on the set back erase time, the last acquired data will be erased

If the measurement has been running for less than the set back-erase time when you press **PAUSE/CONT** key, the entire measurement will be erased upon resuming the measurement. If less than the specified back-erase time has elapsed since you resumed a paused measurement, only the last part of the measurement since the last resume will be erased. Data acquired earlier are assumed to be accepted by you.

The measurement time elapsed counter will be updated to reflect the back erase time. The statistics buffers (optional extension) as well as all other measured parameters will be updated accordingly.

## Displaying the functions measured

The instrument measures the A-weighted and C- or Z-weighted SPL,  $L_{MAX}$ ,  $L_{MIN}$ ,  $L_{eq}$ ,  $L_E$  and the  $L_{PEAK}$ . Note that the SPL,  $L_{MAX}$  and  $L_{MIN}$  are all measured with the selected time constant while the other values are not dependant on this.

The same functions are available in the frequency analysis with the exception of  $L_{PEAK}$ . The peak level is not measured per frequency band. In addition,  $T_{Max5}$  is not available for frequency analysis (applies to units equipped with the optional extension 0).



### What can be done to the measured data?

Data acquired are available for inspection, during or after a measurement.

You may:

- Switch between sound level meter display and frequency spectrum display
- Display the functions measured
- Display the result tables
- Change the spectral weighting function between A- and C- or Z-weighting, this depends on which one you have selected
- Display the eight percentiles (requires the presence of the optional extension 4) and set one of them as you like
- Store the results for future use

However, since the frequency analysis is made in parallel with the traditional (A- and C- or Z-weighted) sound level measurement, the broadband peak levels and the  $T_{Max5}$  levels are still assessed during the measurement.

## No SPL after the measurement

During measurements the SPL value is updated every second. Once the measurement is over, the SPL becomes meaningless. A single SPL value cannot be used to characterise the measurement unless it represents some kind of maximum, minimum or time-integrated average. It is thus not accessible *post-measurement*.

To return to ready mode, i.e. how the instrument behaved before the measurement was started press the **EXIT** key. You will be prompted to store the data or press **EXIT** again. In both cases the instrument will go back to ready mode. The SPL will now be displayed again.

If you choose not to store the data by pressing **EXIT** again, the measured data will be lost beyond retrieval.

## Displaying the result tables

As an alternative to the procedures shown on the next page, you may display all the measured data in tables. Press the **TBL** key to enter table mode. Note that the look of the tables depends on whether you start from sound level meter display mode or from frequency spectrum mode.

The tables are available during, as well as after a measurement. Remember that SPL values are shown during the measurement only.

The tables available are shown in the side bar *Displaying the result tables*.



Instruments configured for the German-speaking markets will measure  $L_{eq}$  (with I time constant) and  $T_{Max5}$  (with F time constant) in addition – see below.



The  $L_{PEAK}$  and  $T_{Max5}$  are not accessible when the spectrum is displayed!

### The functions are available sequentially

To display a certain function, press the **FUNC** key repeatedly until the function appears. The sequence is as follows:

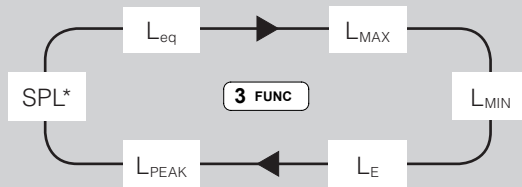

\*Accessible during measurement only – not after!

### Units configured for the German-speaking markets

If also equipped with  $L_{eq}$  and  $T_{Max5}$ , the sequence is as follows (press **FUNC** key repeatedly):

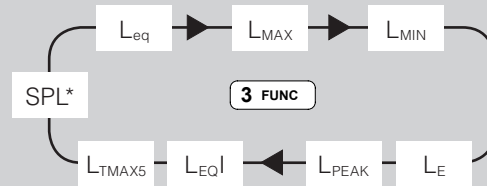

\*Accessible during measurement only – not after!

### Units equipped with multiple time constants

Units equipped with multiple time constants will measure SPL,  $L_{MAX}$  and  $L_{MIN}$  with all three time constants (F, S, I) employed simultaneously. In sound level meter display mode, use the **FUNC** key to produce the function and then **TC** key to display values with the different time constants.

In the frequency spectrum display mode the functions will appear in the following sequence:

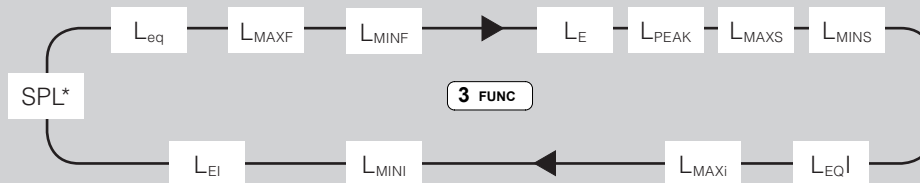

\*Accessible during measurement only – not after!



### Displaying the result tables

#### Sound level meter display mode

To switch between A- and C- or Z-weighted values, use the **NETW** key

1 TBL

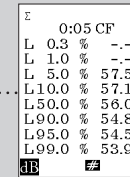
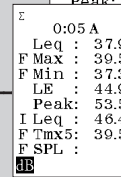
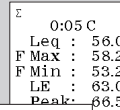
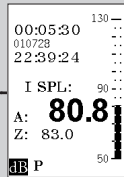

Statistics is optional

Units *not* configured for the German speaking markets will have tables without I Leq (Leq) and Tmx5 values

2 f-t

#### Spectrum display mode

Use the vertical cursor keys to scroll the centre frequency up and down

Use the **FUNC** key to select function

Use the vertical cursor keys to change the frequency band

1 TBL

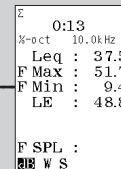
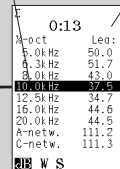
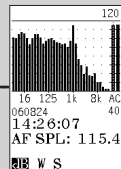

Statistics is optional

### Statistics – displaying the percentiles

Instruments equipped with the optional extension 4 – statistics – will measure the statistics every time. This cannot be switched off.

The sampling for the statistical calculations is made with F time constant and the class width is 0.2 dB over the entire 130 dB dynamic range – always! When the frequency mode has been activated, the instrument does statistics in every frequency band!

You may think that storing all these data will require a huge memory, and you're absolutely right. Therefore, we store just eight percentiles. Seven of them are fixed and one is user-editable.

Your user-editable percentile can be set to anything in the range 0.1–99.9 %, both extremes included.



**Missing percentiles?** There may be percentiles that fail to produce values in the table. This is because you have not measured for a time long enough to provide the necessary number of samples.

Statistical sampling – which should not be confused with the sampling of the analogue-to-digital conversion – takes place 10 times a second. For comparison, the sampling of the analogue-to-digital conversion runs at 48 kHz!

Since the statistical sampling takes place 10 times a second, it will take 10 seconds to produce 100 samples. You will need at least 100 samples to be able to calculate the 1% percentile.

Likewise, for the 0.1% percentile the minimum time required will be 100 seconds. Measurements whose duration is shorter than these minimum limits will not produce percentile values for all possible settings of the percentiles.

### Editing the user-defined percentile

To enable the editing, the instrument must display the percentiles table. In the percentiles table press the **◀** key (the end-left key) to enable this.

Once the percentile field is shown inverted (with white text on black background) the text can be edited using the **NUMERICAL KEYPAD** or **INC** and **DEC**. If you use the **NUMERICAL KEYPAD** you must press **ENTER** to confirm that you have keyed in the new percentile.

To terminate the editing process press the **▶** (end-right key). The corresponding percentile value will now be displayed, given that the measurement duration was long enough to provide a sufficient number of samples.

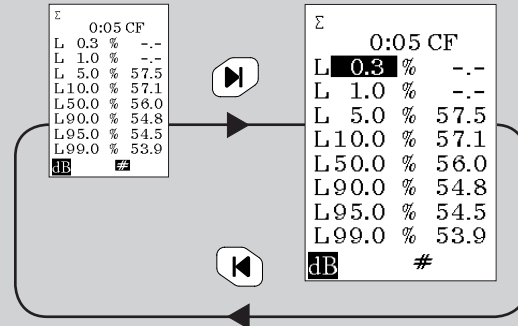

The user-defined setting applies to every network and frequency band. They cannot have individual settings!

Data measured, (not recalled) may be subject to changes in the user-defined percentile. This means you may change the percentile as many times as you want. For stored and later recalled data any changing of the user-editable percentile is no longer possible.

How to set the user-editable percentile is described in the side bar on the previous page.

### Storing the acquired data

The Nor140 has a large, non-volatile memory to hold the measurements. Thus, memory needs no battery power for retaining the data. The same holds for the optional SD-card. The memory structure resembles the memory structure of a personal computer in the sense that both use folders and files.

The structure of the Nor140 is very simple, the folder has the name of today's date and the files are numbered consecutively from 0001 and upwards. This means, of course, that the maximum number of measurements per day is 9999, but this should be a limitation most people will be able to live with. After all, you are going to look through these files later as well, aren't you?

#### *Storing the acquired data:*

- Press the **STORE** key. The display will show the folder and file number as can be seen from the figure.

All aspects of the memory handling are discussed in detail in *Memory handling*.

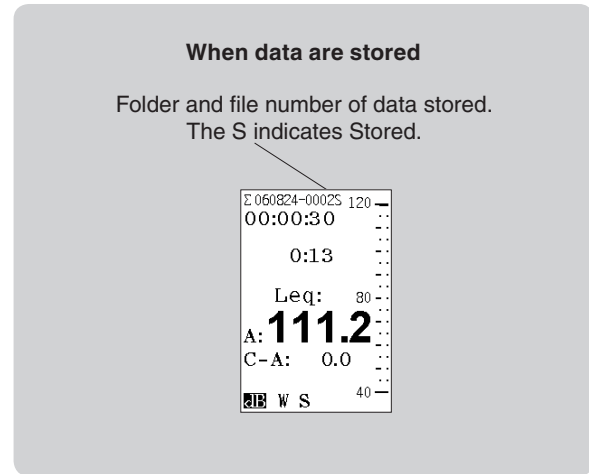

### Printing out the results

By connecting a printer to the RS232 interface, the results can be output to a printer. This is treated in detail in *Making hardcopies*.

### NC, NR and RC rating

Many applications, particularly in the heating and ventilation industry, require the use of noise rating criteria that compare the frequency spectra of the measured noise levels against the reference curves.

The NC – Noise Criteria, NR – Noise rating and RC – room criteria are supported in the Nor140, all returning a single dB value based on frequency rating curves. The noise rating criteria requires that the instrument is equipped with the 1/1 octave option. The rating is also calculated if the measurement is performed with 1/3 octave spectra. In this case the Nor140 is automatically recalculating the 1/3 octave values to 1/1 values prior to the noise rating calculation

Noise Criterion - NC - were established in U.S. for rating indoor noise and noise from air-conditioning equipment etc. In Europe it is more common to use Noise Rating Curves – NR. The method consists of a set of criteria curves extending from 63 to 8000 Hz for the NC rating and from 31.5 to 8000 Hz for the NR, and a tangency rating procedure. The criteria curves

define the limits of octave band spectra that must not be exceeded to meet occupant acceptance in certain spaces.

Similar the RC – room criteria value is based on a set of criteria curves in the frequency range from 16-4000 Hz. The RC value however is only based on the three octave bands 500 Hz, 1 kHz and 2 kHz. In addition is H (Hiss) and or R (Rumble) added to the value. The R is added if any 1/1 octave band between 16 Hz and 500Hz is crossing the determined RC rating curve. Similar a H is added if the 2000 or 4000 Hz 1/1 octave band is crossing the determined RC curve.

The rating value (NC, NR and RC) is obtained by plotting the octave band levels for a given noise spectrum - the rating curves. The noise spectrum is specified as having a rating same as the lowest rating curve which is not exceeded by the spectrum. The rating evaluation is performed in 1 dB steps.

The rating values are found in the bottom of the frequency spectrum table. Push the TBL button in the frequency display to get access to this table.

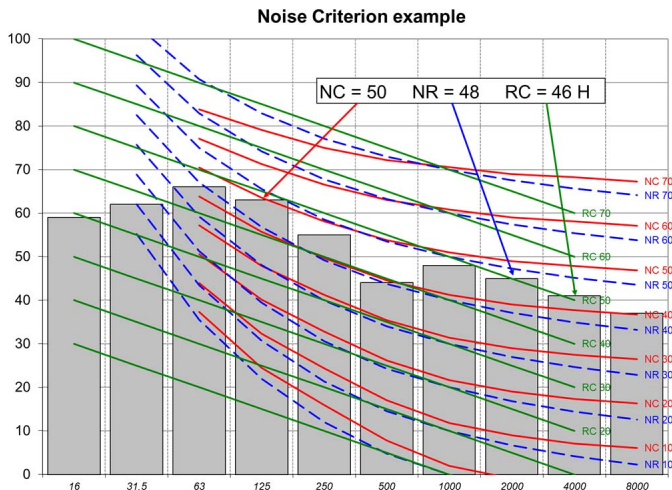

The noise criterion evaluation search the highest 1/1 octave band that fits below the applicable noise criterion lines. The evaluation is performed in 1 dB steps. 1/3 octave spectrums are re-calculated into 1/1 octave spectrums prior to evaluation

# Basic time profile measurements

Instruments equipped with the optional extension 6, level vs. time will be able to log the time profile like the classic level recorders used to do.

The time profile is measured by dividing a total measurement into smaller periods of time, all having the same duration. Extension 6 allows the period length to be from 1 second and upwards in 1 second steps, while the enhanced profile (the optional extension 7) allows a period length from 50 ms and upwards in 25 ms steps (but in 1 second steps above 1 second period length).

The logged profile may be transferred to a PC for further analysis. Software like Nor1026 NorReview may be used for extensive analysis of the result.

## Global vs. profile

The traditional sound level measurement and the frequency analysis both consider the entire measurement as a whole without dividing it into smaller parts. One may therefore consider these two measurements as global measurements, while the level vs. time measurements represent the *profile*.

In the display, the global measurements are denoted  $\Sigma$  (pronounced sigma) while the profile measurements are denoted  $\Delta$  (pronounced delta). To switch between the modes, just press the  $\Sigma \leftrightarrow \Delta$  key.

The  $L_{eq}$ ,  $L_{MAX}$  and  $L_{MIN}$  are measured for every period separately and stored in a buffer. All functions are A-weighted apart from the peak level which can be set as C-or Z-weighted. The enhanced profile (ext. 7) provides more options – see Enhanced profile measurements.

Profile measurements may be made in parallel with global frequency analysis (filters are optional) and in parallel with the traditional sound level measurement described in the chapter Simple sound measurements. If your Nor140 is equipped with the multi-spectrum extension, you may log the spectrum as a function of time. See *Multispectrum measurements* for more on this.

---

The time profile is no less than an electronic level recorder!

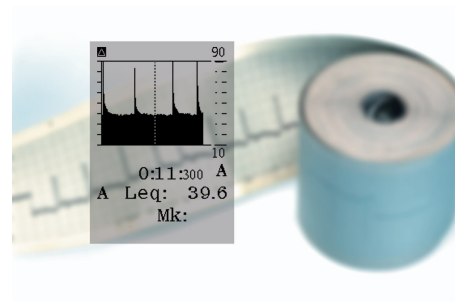

### The measurement duration setup menu

Total (global) duration of measurement.	<u>Meas.dur.:</u>
Selected resolution	Duration: 00:00:05
No. of periods with selected duration and resolution	Resolution: 00:00:01
Max. No. of periods (depends on the amount of free memory available)	N: 5
	Mx: 707174 #

The profile resolution does not have to be selected so that the global duration becomes a multiple of the profile resolution. The last period will be truncated if the duration divided by the profile is not an integer.



#### Which resolution should you use?

This will always be a trade-off between the need for information and the amount of data generated. You should also take into consideration the global duration of your measurement.

For example, you may want a higher resolution in a 1 minute measurement than in a 24 hour measurement. Will you need a 1 second resolution for 24 hours? It's going to be a lot of information to go through afterwards.

No absolute rules or guidelines can be given since there are so many different applications and requirements.

### The time profile display

The  $\Delta$  indicates the profile (global is indicated by a  $\Sigma$ )

Graph cursor. Use  $\blacktriangleleft$   $\blacktriangleright$  keys to move the cursor along the graph. This feature is not available during a measurement

Display top scale

Spectral weighting function applied to the right hand bargraph,

Measurement running

Value at cursor's position

### Pause and profile

Here, the instrument is in **pause** mode. Global acquisition is halted, but the profile is still acquiring data. The thin line below the graph represents a marker associated with the periods acquired while paused. The meaning of the line below the graph is given by the text: Mk: P which should be interpreted as Marker: Paused to indicate that these data will not be a part of the global level assessment.

### Displaying the result tables

#### Sound level meter display mode

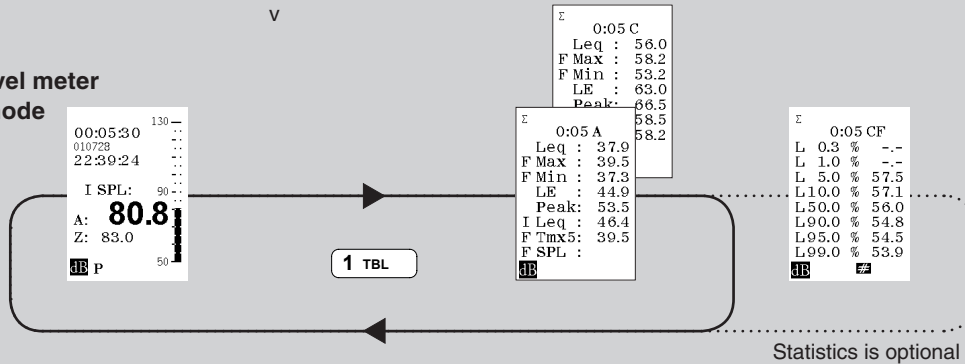

Units *not* configured for the German speaking markets will have tables without I Leq (Leq) and Tmx5 values.

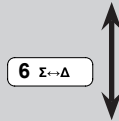

To move the graph cursor use the ◀▶ keys, but not during a measurement, only after.

#### Profile display mode

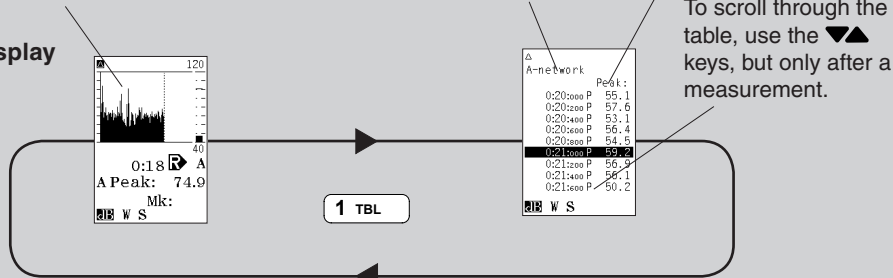



### No back-erase in profile pause mode.

The resumption of a paused measurement will cause up to 20 seconds (adjustable from 0 - 20 s) acquired immediately before the pause to be erased. This applies to the global measurement, but not to the profile.

Assume you have set up the measurement to also include profile and that the measurement is running. If you press pause, the global data acquisition will be halted, but the profile will still acquire data! These data will be marked P for pause to denote that they were acquired in pause mode and that they do not participate in the global level assessments.

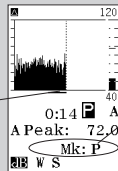

The line denotes periods are marked

The pause marker

When you later press pause again to resume, the amount of periods marked as paused will be expanded backwards in time (about 10 seconds) to include periods acquired in the time-span subject to back-erasure in the global mode.

The reason why we designed it this way, was to provide you with the complete overview – if you later transfer the acquired data to your PC you will be able to do calculations on any parts of the profile while at the same time you'll be able to see the intervals that didn't take part in the global assessments.

Consequently, the duration of the measurement will seem ambiguous. The global duration will be less the pause and less any back-erase, while the profile will have a duration including the pause length and without back-erase!

This chapter deals with profile measurements only. For details on global frequency analysis see the chapter *Frequency analysis*.

## Making measurements

All you need to do to set up the Nor140 to expand the measurements to also include the time profile is to define the time resolution.

### To define the duration and the resolution:

- 1 Press **SETUP > 2**. Units with the option 6 installed will then produce the measurement duration menu. See side bar for details.
- 2 Set the global duration.
- 3 Move down to resolution and set as required. Make sure that number of periods, N, is below the maximum value. Navigate and leave the menu as usual.

If you've set up a profile resolution different from (i.e. shorter than) the global measurement duration, the instrument will log the time profile in addition to the global measurement.



The effect of pressing stop before resuming. If you terminate an ongoing measurement prematurely by pressing the **STOP** key and later resume the measurement by pressing **PAUSE/CONT** an S marker will be added to the period within which the **PAUSE/CONT** key was pressed – i.e. we mark out the first period after resumption.



**To start the time profile measurement:**

- Press **START**.

**To switch to see the time profile:**

- Press the **Σ↔Δ** key. To return to global mode press the key again.

The features available while measuring – described in the chapters *Simple sound measurements* and *Frequency analysis* apply even here.

**Presenting the L(t) as a table**

Numerical presentation of the acquired data works even here. Press **TBL** while in  $\Delta$  (profile) mode to produce the table. This can be done during, as well as after, a measurement. An example of the table is shown in a side bar on the preceding pages. Use **▼▲** keys to move the cursor up and down, but only after the measurement have ended.



**Functions measured in the basic time profile mode.** In the basic time profile mode, the instrument logs the A-weighted equivalent level, the A-weighted maximum sound pressure level and the Z- or C-weighted peak level.

At the same time, the global mode measures the instantaneous SPL, the maximum and the minimum SPL, the equivalent level, the sound exposure level and the maximum peak level. All the global levels are measured as A-weighted and Z- or C-weighted levels.

# Enhanced time profile measurements

The optional extension 7 – enhanced time profile lets you select the functions to be measured as a function of time. Select from A-weighted functions as well as C- or Z-weighted – even A-weighted peak! Furthermore, enhanced profile opens up for the use of source coding – see *Adding markers* for details. Apart from this and the lower limit for time resolution, there is no difference between basic and enhanced time profile mode.

## Selecting which functions to log

We always recommend that you keep the number of functions to measure as small as possible. This helps to maintain the overview and keeps the amount of memory spent low. Although it may be tempting to measure “everything”, do not forget that you are going to review the acquired data afterwards. How much time are you willing to devote to that?

### Setting up the functions to log:

- 1 To gain access to the profile function activation menu, press **SETUP > 3** [L(t) par.]. This menu looks as shown to the right.
- 2 Navigate in the menu as usual and use the **INC** and **DEC** keys to activate the functions required for your task. Deactivate those that you won't need. A “1” means activated and a “0” means deactivated.

- 3 The set up for both the A-weighted and the C- or Z-weighted functions and filter bands, if available, are accessible from within this menu. Use the **NETW** key to switch between filters, A- and C- or Z-weighted (which is set up in the 2nd network menu – see Simple sound measurements for more on this).

Units with multiple time constants installed may include the time constant setting in the setup – see the Fig. below left.

**Functions to log – setup menu**

L(t) par.:	F	S	I
A SPL:	1	0	0
A Leq:	1	0	
A Max:	1	1	1
A Min:	0	0	0
A LE :	0	0	
A Peak:	0		
	#		

L(t) par.:	F
A SPL:	1
A Leq:	1
A Max:	1
A Min:	0
A LE :	0
A Peak:	0
	#

Setup menu with multiple time constant option (left) and without the multiple time constant option (right)

Functions like  $L_{eq}$ ,  $L_{MAX}$ ,  $L_{MIN}$  and  $L_{PEAK}$  are measured during each period. The SPL, however, is sampled at the end of each period.

### Copy the setting to Prnt/Xfer

Upon leaving the functions to log menu you will be prompted to decide whether the settings you made shall apply to the functions to print or transfer

In order to avoid being totally drowned in values, you may set up instrument to just print a few of the functions measured. However, for convenience we offer the feature of setting up the same functions for printing as for measurement. If you then want to print fewer functions, just go to the print functions setup menu and deactivate those you won't need.

### To produce the print functions setup menu:

- Press **SETUP > 1 > 9 > 1**

Functions to be printed are denoted by a "1". The same applies to the transfer of measured function values to your PC. You may not want to have all the data transferred, so you can set up which functions whose values you want to transfer.



#### The time constant cannot be set from inside the L(t) par menu!

Instruments which are not equipped with multiple time constants will make use of the time constant currently selected. If this is not the one you want to use for your profile measurements, you must change it. This cannot be done from within the L(t) par menu. Leave the menu and change the time constant by means of the **TC** key.

### To produce the transfer functions setup menu:

- Press **SETUP > 1 > 9 > 2**

## Setting the time resolution

### To define the duration and the resolution:

- 1 Press **SETUP > 2**. Units with the option 6 installed will then produce the measurement duration menu. See side bar for details.
- 2 Set the global duration.
- 3 Move down to resolution and set as required. Navigate and leave the menu as usual.

If you have set up a profile resolution different from (i.e. shorter than) the global measurement duration, the instrument will log the time profile in addition to the global measurement.

Option 7 permits the time resolution to be as low as 25 ms. See text for details

<b>Meas.dur.:</b>	
Duration:	000:00 <b>105</b>
Resolution:	125 ms
N:	40
Mx:	68042
<b>W S #</b>	

Here the resolution is set to 125 ms



### No back-erase in profile pause mode.

The resumption of a paused measurement will cause up to 20 seconds (adjustable from 0 - 20 s) acquired immediately before the pause to be erased. This applies to the global measurement, but not to the profile.

Assume you have set up the measurement to also include profile and that the measurement is running. If you press pause, the global data acquisition will be halted, but the profile will still acquire data! These data will be marked P for pause to denote that they were acquired in pause mode and that they do not participate in the global level assessments.

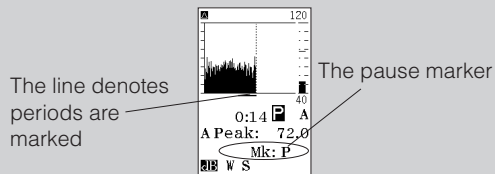

When you later press pause again to resume, the amount of periods marked as paused will be expanded backwards in time (about 10 seconds) to include periods acquired in the time-span subject to back-erasure in the global mode.

The reason why we designed it this way, was to provide you with the complete overview – if you later transfer the acquired data to your PC you will be able to do calculations on any parts of the profile while at the same time you'll be able to see the intervals that didn't take part in the global assessments.

Consequently, the duration of the measurement will seem ambiguous. The global duration will be less the pause and less any back-erase, while the profile will have a duration including the pause length and without back-erase!

The enhanced profile offers a time resolution (period length) down to 50 ms! Between 50 ms and 1 s the resolution is adjustable in 25 ms steps. Above 1 s the step size is 1 s as is the case for the basic profile.

### Setting a period length lower than a second

- Set the resolution to 1s and press the **DEC** key to enter the ms area. Scroll down to the required setting or use the numerical keypad as usual after the ms sign appears. Note that if you keep the **DEC** key (or the **INC** key) depressed it will, after a while, speed up the scrolling.

or

- Key in 59 s as the resolution and then press **ENTER** followed by **INC**, the resolution will be set to 50 ms immediately. Press **INC** to adjust, or use the **NUMERICAL KEYPAD** to set the value directly. Step size is 25 ms. If you key in a value between valid settings, the value will be put to the nearest valid setting.



### The effect of pressing stop before resuming.

If you terminate an ongoing measurement prematurely by pressing the **STOP** key and later resume the measurement by pressing **PAUSE/CONT** an "S" marker will be added to the period within which the pause/cont key was pressed – i.e. we mark out the first period after resumption.

## Measuring in enhanced mode

The enhanced time profile mode is similar to the basic time mode and should thus be regarded as an add-on to the instrument's basic functionality. This means that the features available while measuring – described in the chapters *Simple sound measurements* and *Frequency analysis* apply even here.

## Displaying the functions measured

To see the different functions measured, just use the **FUNC** key as usual.

## Presenting the L(t) as a table

Numerical presentation of the acquired data works even here. Press **TBL** while in  $\Delta$  (profile) mode to produce the table. This can be done during, as well as after, a measurement. Use **▼▲** keys to move the cursor up and down, but only after the measurement have ended.

# Adding markers to a measurement

Have you ever made a measurement where you later found out that you desperately need to identify the cause of the level?

Enter *source coding*. With the enhanced profile option (optional extension 7) you may tag or code sources as they happen. A one digit code (which appears in the display as 1~4) is entered to later serve as an identification of the type of noise. This can also be referred to as adding a marker to the measurement.

---

What were these impulses caused by?

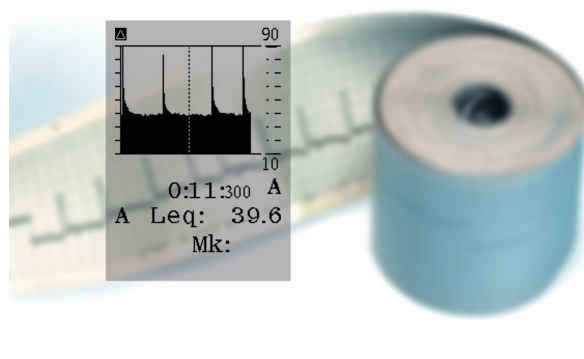

**Example:** In a traffic noise measurement a bus passing may be identified by the digit “1”, while trucks may be identified by “2”, unexpected vehicles by “3” etc. In the profile display the markers appear as dots or lines below the graph. If you move the time cursor onto such a dot, the marker type (i.e. its number) will appear in the display.

During a measurement, adding any of the markers “1”, “2” and “3” will assign the corresponding marker number to the current period only.

When you press marker number “4”, however, the marker will stay on until the key is pressed again. The marker will therefore be assigned to the current period plus all consecutive periods until the marker again is deactivated. This marker type is often referred to as a toggle marker, as opposed to the single marker which is the other type. A typical application for a toggle marker is to mark out intervals of particular interest.

## The keys to use

The keys used to enter the markers are **PRINT** (marker 1), **MODE** (marker 2), **CAL** (marker 3) and **EXIT** (marker 4) since these keys are the lower most keys of the front panel and thus easy to reach during a measurement. None of these keys are used for other things during a measurement either.

## Other markers inserted by the instrument

As discussed in the side bar *No back-erase in profile mode* (in chapter 7) the *single* marker “P” is added to the periods to denote that these periods contain data acquired in pause mode.

In addition, if you terminate an ongoing measurement prematurely by pressing the **STOP** key and later resume the measurement by pressing **PAUSE/CONT** an “S” *single* marker will be added to the period within which the **PAUSE/CONT** key was pressed – i.e. we mark out the first period after resumption.

An “R” *toggle* marker will be added during record of the signal (Option 8). If some of the specified tasks has been omitted due to work overload for the signal processor, a “W” *toggle* maker will be added.

The total number of recorded signals, and hence inserted “R” markers, for one measurement is limited to 1000. In addition, each measurement may contain up to a total of 1 000 markers of all the other kinds. In these limitations, each toggle marker only counts as one marker.

## Instrument markers have priority

The marker “4” is a *toggle* marker, i.e. once activated it will assign a marker to every period occurring until it is deactivated again.

What happens if marker “4” has been activated while you press the **STOP** key or the **PAUSE/CONT** key? Will it assign both “4” and “P” or “S”? No, it won't! “P” and “S” have priority and they will be inserted instead of any other marker active by the time pause or stop is pressed. So you'll never have more than one marker assigned to a profile period.

## Marker overview

- 1 M1 marker
- 2 M2 marker
- 3 M3 marker
- 4 M4 marker (toggle)
- S Stop
- P Pause
- A Audio record
- \*(OL) Signal overload
- W Work overload  
(too many functions selected)

Marker “1” has been inserted

The keys used to insert markers.



# Multispectrum measurements

The combination of filters (minimum option 1) and time profile mode (minimum option 6) takes the instrument to greater sophistication by introducing multispectrum measurements.

This upgrade of time profile permits complete spectra to be measured as a function of time – not just broadband values (albeit spectrally weighted). You may then track a given frequency band as a function of time or inspect the spectrum at a given moment in time. This is illustrated by the dotted lines in the below Fig.

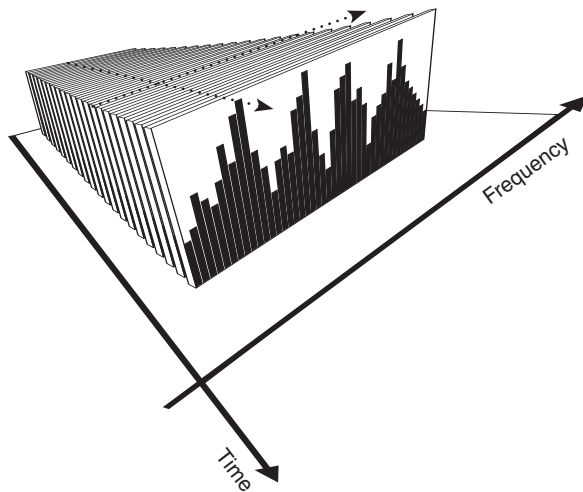

## Setting up for multispectrum

Multispectrum measurements can be made based on basic- as well as enhanced time profile extensions installed.

### Instruments equipped with basic profile extension

Units equipped with basic time profile extension (and filters, of course), have a very simple setup procedure:

#### To set up for multispectrum measurements (basic time profile):

- 1 Set up the instrument to make time profile measurements as described in *Basic time profile measurements*.
- 2 Press **SETUP > 4** and activate the filters as described in the chapter *Frequency analysis*. Navigate, set the parameters and leave the menu in the usual manner.

The instrument is now ready to make multispectrum measurements

### Sound level meters equipped with enhanced profile extension

Instruments with enhanced time profile extension installed, have a few more things to set.



**To set up for multispectrum measurements (enhanced time profile):**

- 1 Set up the duration and resolution
- 2 To gain access to the profile function activation menu, press **SETUP > 3** [L(t) par.]. This menu looks as shown below.

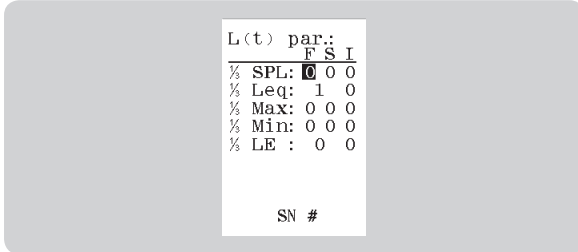

- 3 Navigate in the menu as usual and use the **INC** and **DEC** keys to activate the functions required for your task. Deactivate those that you won't need. A "1" means activated and a "0" means deactivated.

This menu is used to activate/deactivate:

- the A-weighted functions to be measured
- the C- or Z-weighted functions to be measured
- the filter band functions to be measured

**Functions to log – setup menu**

L(t) par.:  
F S I

A SPL: 1 0 0

A Leq: 1 0

A Max: 1 1 1

A Min: 0 0 0

A LE : 0 0

A Peak: 0

#

Use  
the **NETW** key  
to gain access to  
the C/Z-weighted  
functions and the  
filter band func-  
tions as well

L(t) par.:  
F

A SPL: 1

A Leq: 1

A Max: 1

A Min: 0

A LE : 0

A Peak: 0

#

Setup menu with multiple time constant option (left) and without the multiple time constant option (right)

Use the **NETW** key to switch between A-weighted functions, the C-/Z-weighted functions *and* the filter band functions. Remember that the filter functions must be turned on (using **SETUP > 4**) before they can be selected in this menu. If you fail to activate functions for the filter bands, there will be no multispectrum data, either.

**Making multispectrum measurements**

Multispectrum measurements are made in the same way as ordinary time profile measurements. The only difference lies in the fact that the multispectrum measurements log the spectrum as a function of time and not just the broadband values.

**To go between level vs. time and level vs. frequency:**

- 1 Make sure the instrument is in profile mode (a Δ displayed in the upper left corner of the display). If not, press the **Σ↔Δ** key to enter profile mode.
- 2 Use the **f↔t** key to go between display of level vs. time and level vs. frequency.

**To move the cursor along the frequency axis:**

- 1 Make sure the display shows the spectrum. If needed, use the **f↔t** key.
- 2 Use the **◀** and the **▶** keys to move the cursor along the frequency axis.
- 3 Use the **◀◀** and the **▶▶** keys to move the cursor to either extremes of the spectrum.



**Are you going to use C- or Z-weighting as spectral weighting function?** This is set up in the 2nd network menu – press **SETUP > 1** (Instr.) **> 5** (2nd netw) and navigate as usual.

**To move the cursor along the time profile axis:**

- 1 Make sure the display shows the time profile (level vs. time). If needed, use the **f↔t** key.
- 2 Use the **◀** and the **▶** keys to move the cursor along the time axis.
- 3 Use the **◀** and the **▶** keys to move the cursor one screenwidth along the time axis in either direction.

**To see the spectrum of another moment in time:**

- 1 Make sure the instrument is in profile mode and that the spectrum is displayed (a **Δ** displayed in the upper left corner of the display). If not, press the **Σ↔Δ** key to enter profile mode and the **f↔t** key to enter the frequency domain.
- 2 Use the **▲** and the **▼** keys (repeatedly, if needed) to reach the moment in time required.

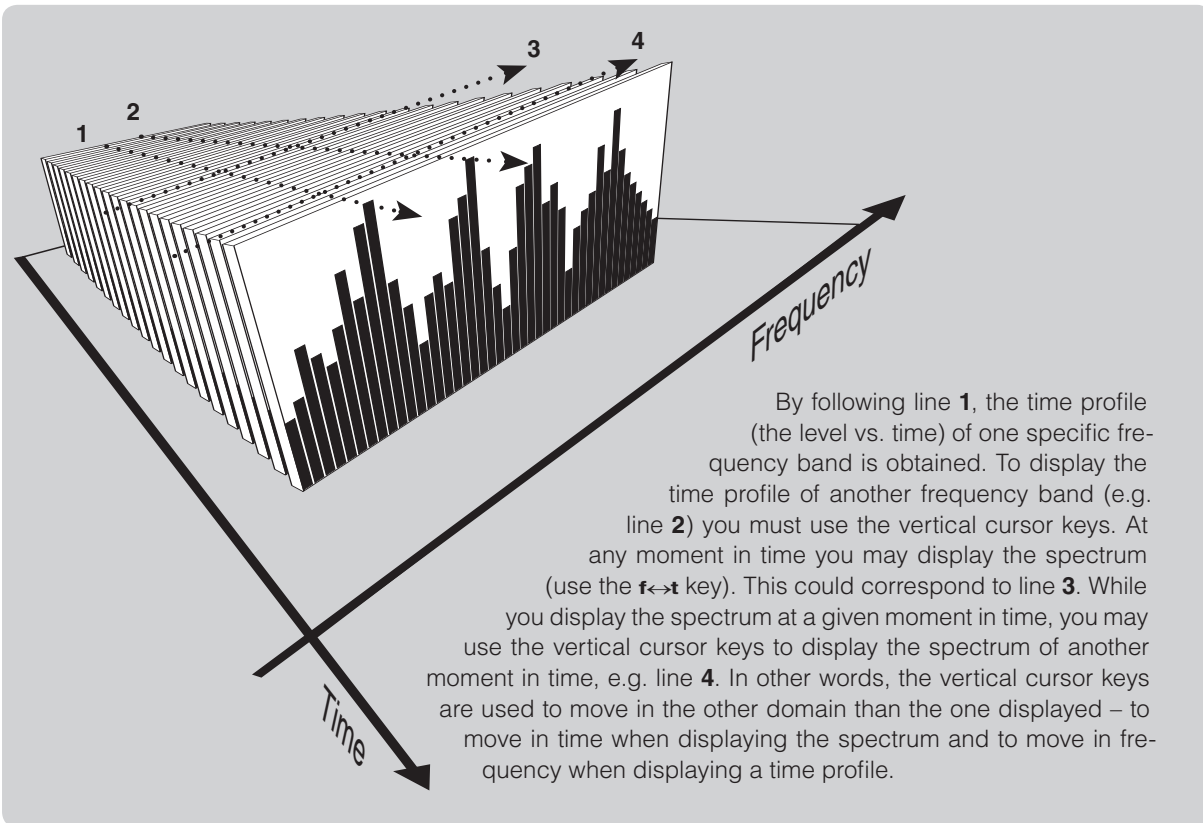

**To see the level vs. time (the profile) graph of another frequency band:**

- 1 Make sure the display shows a time profile (level vs. time). Use the **f↔t** key, if needed.
- 2 Use the **▲** and the **▼** keys (repeatedly, if needed) to move to another frequency band.

**To see the global values:**

- 1 Make sure the instrument is in global mode (a  $\Sigma$  displayed in the upper left corner of the display). If not, press the  **$\Sigma$ ↔ $\Delta$**  key to enter global mode.
- 2 Use the **f↔t** key to go between the sound level meter display and the spectrum display. Move the spectrum cursor as explained above.

The spectrum you see now is the global spectrum. This spectrum should not be confused with the multispectrum feature.

**The result tables**

The measured values can be presented tabulated as usual. In multispectrum mode there are two tables available in profile mode:

- Each function shown for all frequency bands (use the func key to go to another function)
- The functions measured shown for a single frequency band or spectral weighting network.

These are shown in the Fig. to the right as well as overlaid together with the displays and tables available for the global part of the measurement.

**To produce the result tables in multispectrum mode:**

- 1 Press **TBL** once to produce Table 1 and again to produce Table 2.
- 2 Press again to return to graphical display.

Table 1

Δ020419-0004S	
0:27:500	
½-oct	Leq:
5.0 kHz	22.1
6.3 kHz	19.9
8.0 kHz	18.4
10.0 kHz	19.0
12.5 kHz	19.0
16.0 kHz	17.3
20.0 kHz	21.9
A-netw.	48.4
C-netw.	-.-
<b>dB</b>	

Use **▼▲** keys to move up and down in table, **◀▶** keys to move to another moment in time and **FUNC** to scroll through the functions measured.

Table 2

Δ020419-0004S	
0:27:500	
A-network	
<b>F SPL:</b>	<b>48.6</b>
Leq:	48.4
F Max:	49.3
F Min:	48.6
S Min:	54.1
<b>dB</b>	

Use **▼▲** keys to move up and down in frequency (incl. spectral weighting networks) and **◀▶** keys to move to another moment in time and **FUNC** to scroll through the functions measured.

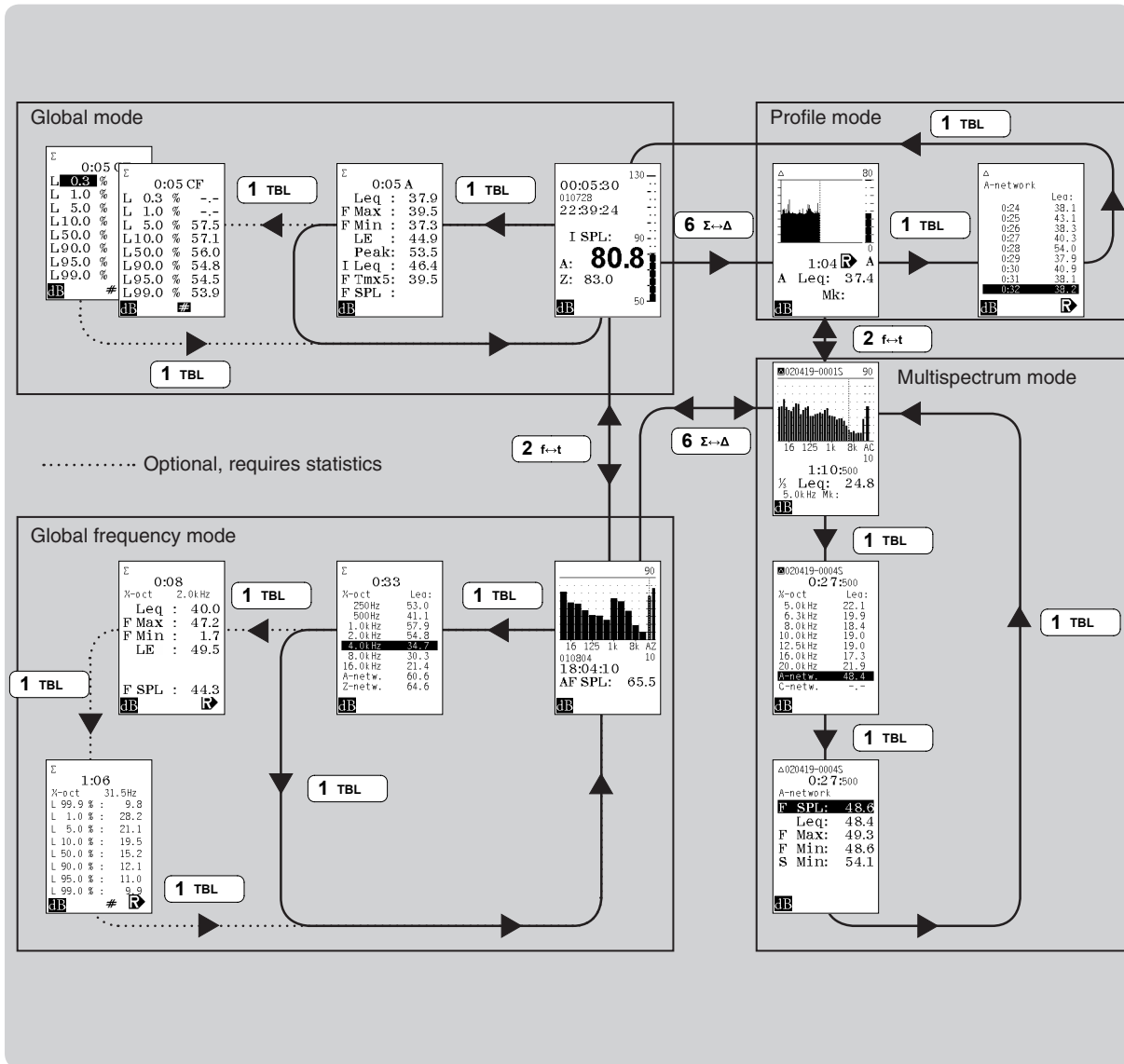

The key pressing sequence is also illustrated in the Fig. overleaf, while operating details are provided below. Both tables are accessible during measurement, you can even start a measurement from within any of the tables! All functions available for a profile measurement apply even here. If your instrument supports the use of markers, they may be used in the usual way.

Pause and global back-erasure also works as usual. For a discussion of these features, turn to *Enhanced time profile measurements*, *Basic time profile measurements* and *Adding markers to a measurement*.

# Engineering units

## Introduction

The “Engineering Units” feature allows you to recalculate and display the result in physical units, e.g. the sound pressure may be indicated in Pascal instead of decibel. In conjunction with other sensors than the usual microphone, the general “EU” sign may indicate any relevant physical quantity.

All values are still stored as level values. This allows even stored results to be displayed as **dB** or **EU** dependent on the selected setup when the results are retrieved and displayed. The selected format for units, either **dB** or **EU** is indicated in the lower, left corner of the screen as shown on Fig. below.

When values are transferred to a PC, the **dB** format will be used independent of the setting in the instrument.

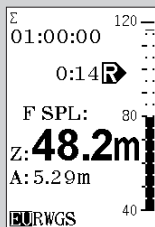

Engineering units is indicated by an **EU**-sign in the lower, left corner of the display

## Selecting Engineering Units

The selection between levels in decibel or linear units in “EU” is selected in the instrument set-up menu.

Press **SETUP** and select

**1** Instr, > **9** Misc. par > **6** Units

Use the field cursor to highlight **dB** or **EU** as appropriate and press **ENTER** repeatedly until you are back in the ordinary display.

## How values are indicated

Due to the high dynamic measurement range for Nor140, the measured values displayed in linear units will vary over more than six decades. By changing the sensitivity of the instrument (calibration), the display range may need to cover nearly twelve decades. A floating-point format for the linear indicated value is therefore necessary. A letter following the numeric value is used for indicating the power-of-ten exponent. The following letters are used:

The graphical display is left unchanged when engineering units are selected.

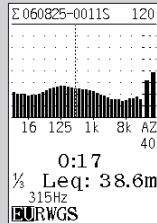

f	10 <sup>-15</sup>	(femto)
p	10 <sup>-12</sup>	(pico)
n	10 <sup>-9</sup>	(nano)
u	10 <sup>-6</sup>	(micro)
m	10 <sup>-3</sup>	(milli)
k	10 <sup>3</sup>	(kilo)
M	10 <sup>6</sup>	(mega)
G	10 <sup>9</sup>	(giga)
T	10 <sup>12</sup>	(terra)

An underscore “\_” is used if no other postfix characters apply. The following examples may illustrate the principle:

$$189\text{m} \leftrightarrow 189 \times 10^{-3} \leftrightarrow 0.189$$

$$78.3\text{u} \leftrightarrow 78.3 \times 10^{-6} \leftrightarrow 0.0000783$$

## Relation between dB and EU

The logarithmic dB scale is a scale relative to a common reference value. In the Nor140 instrument the reference value is always  $2 \times 10^{-5}$  corresponding to the common reference value for sound pressure levels: 20  $\mu\text{Pa}$ . A linear quantity X will therefore correspond to a level

$$L_X = 10 \lg \left\{ \frac{X^2}{X_0^2} \right\}$$

where

$$X_0 = 2 \times 10^{-5}$$

This implies that 1 EU corresponds to 93,979...dB or as usually stated 94 dB.

## Calibration

The sensitivity is always expressed as a logarithmic sensitive in dB relative to 1 volt/EU. Even if engineering units are selected, the sensitivity still has to be specified in this way. However, if a calibration signal is presented to the input, the indication will be in engineering units or decibel dependent upon the selected setup. Use the **INC** or **DEC** keys as usual for adjusting the sensitivity in 0.1 dB step.

If you want to calculate the sensitivity, some examples may clarify the procedure.

**Example 1**

A microphone with preamplifier has a sensitivity of 50 mV/Pa or 0.05 V/Pa. The SI-unit pascal [Pa] is now used as “EU”. The logarithmic sensitivity will be:

$$L_s = 10 \lg \left\{ \frac{\left(0,05 \frac{V}{EU}\right)^2}{\left(1 \frac{V}{EU}\right)^2} \right\} = -26.02 \text{ dB}$$

If you set the sensitivity to this value and dB is selected, the sound pressure will be indicated in dB relative to 20 μPa. If EU is selected, the signal will be indicated in pascal. Normal levels will correspond to the root-mean-square value (RMS), but the peak value will correspond to the absolute value of the pressure peak.

Set the sensitivity level  $L_s$  to 0 dB. The indication in engineering units will then correspond to the voltage in volt of the signal presented at the input terminal (microphone socket).

**Example 2**

The combination of an accelerometer and an amplifier has a sensitivity of 20 mV/ms<sup>-2</sup>. The unit for acceleration, ms<sup>-2</sup>, is now the engineering unit. The logarithmic sensitivity will be:

$$L_s = 10 \lg \left\{ \frac{\left(0,02 \frac{V}{EU}\right)^2}{\left(1 \frac{V}{EU}\right)^2} \right\}$$

Setting the instrument to this sensitivity and selecting EU will make the instrument indication to be vibration expressed as m/s<sup>2</sup>.



# Memory handling

The instrument has a large built-in, non-volatile memory which can hold large amounts of measured data and measurement setups. These data can be transferred to a remote PC for further processing and/or printed out.

In addition, the data may be stored on a SD-card. Cards up to 8GB may be used, but we recommend Industrial Grade cards up to 2GB since they are faster and more reliable than the inexpensive standard cards you can get for digital cameras and cellular phones.

Please note that no file in the system may exceed the 4 GB limit. This file size is only possible to achieve with audio recordings, and it corresponds to a recording of approximately 8 hours using 48 kHz sampling 24 bit resolution or 92 hours of 12 kHz 8 bit resolution.

## Memory structure

The memory structure of the Nor140 is quite similar to that of a PC. They both have folders and files. However, simplicity is a keyword in the Nor140 memory handling, the folder available for storage has the name

---

A memory structure metaphor

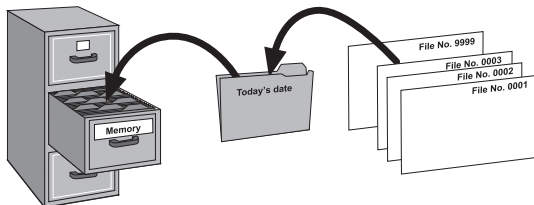

of today's date and the files are numbered consecutively in ascending order as they are stored, starting at 0001.

## Internal memory size

The available internal memory for storing of measurements is approximately **25 megabytes**. This is a number which says more or less nothing to most people since it reveals nothing of the number of bytes required to store the measured values etc. Let us therefore provide a few examples.

**Example 1.** The internal memory can hold more than 50 000 global measurements with all available global functions and distribution when frequency analysis has been deactivated.

**Example 2.** The memory can hold more than 12 000 global measurements with all available global functions and distribution when frequency analysis has been activated.

**Example 3.** The memory can hold approximately 1 250 000 samples of  $L(t)$  when only one function is logged (requires the enhanced profile extension). This corresponds to more than 300 hours logging with 0.1 s resolution!

**Example 4.** The memory can hold more than 450 000 samples of  $L(t)$  when all 28 functions are logged in profile (requires enhanced profile and multiple time constants). This corresponds to more than 125 hours with a resolution of 1 s.

## Select the device for storing

You may select either the internal memory or the optional SD-card as the location for storing data. You have one selection for measurement setups and one for the result of the measurements. The selection is done in the instrument menu:

- Press **SETUP > 1** (Instrum.) **> 1** (Storing)
- Use the cursor key and move to the field for setup. Use the **INC** or **DEC** key to select the wanted place for storing the setup.
- Use the cursor key and move to the field for Result. Use the **INC** or **DEC** key to select the wanted place for storing the result of measurement.
- Press **ENTER** repetitively for returning from the menu system.

## SD-card memory

A SD memory card (Secure Digital) may be used for storing set ups, measurement data and sound recordings. The card is located at the left side of the instrument behind the rubber protection. Card with memory size up to 8 GB may be used, but we recommend using card with memory size 2 GB or less as operation on such card will be faster. Note: Do not use miniSD without a proper adapter. Since the card may easily be removed from the instrument and placed in a card reader connected to your PC, the SD-card is also a convenient device for transfer of data.

*Never remove the card from the instrument during reading or writing operations!*

## Format

Always format the SD-card *in the instrument* before first time use. Formatting a card is also the fastest way for deleting all data on the card. We recommend that you format your card from time to time. After a time with normal use where files are stored and deleted, the file structure may be fragmented which lower the speed for transfer of data.

The card may be formatted by the following operation:

- Insert the card in the card slot on the left side of the instrument.  
  
Make sure the instrument is set to store results on the SD card. (**SETUP > 1**(Instrument) **> 1**(Storing)).
- Press the **DEL** key
- The upper line in the display should read "Clear: SDC", if not press **INC** or **DEC**
- Press cursor left ◀ **> ENTER**
- Scroll down to **FORMAT** and press **ENTER**
- Confirm the **FORMAT** selection and press **ENTER**
- Wait until the format operation has been completed.

## Storing a measurement setup

Measurement setups can be stored for future use. This can be handy feature when the instrument is used by several people or for many different tasks.

This measurement has been stored as file No. 7 in today's folder (S for stored)

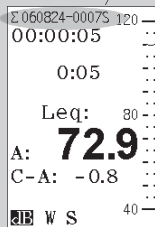

This is setup No. 4 stored in this instrument (S for stored)

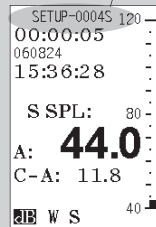

## General

Most set-up parameters are stored separately for each mode of operation. As an example, you don't have to readjust the filter bandwidth to 1/3-octave due to a previous measurement of STIPA, which requires a full octave bandwidth.

The mode related set-ups cover most measurement parameters such as selection of network, measurement time, time resolution, frequency resolution etc. However, some parameters are global and adjustment in one mode will define these parameters also when the instrument is operated in a different mode.

## Global parameters

The following parameters are global and adjustment in one mode of operation for the instrument will be valid also in other modes of operation:

- Microphone sensitivity (calibration)
- Preamplifier/Polarisation voltage
- Calendar/clock settings
- Serial interface on/off and baud rate or USB-selection
- Second weighting-network (C- or Z-weighting)
- Level range (Normal/High)
- Units (dB or engineering units)
- Corrections on/off
- Printer
- Language (for print)
- Instrument identification (Option 11)



If you have made a measurement and the instrument presents a result, the **STORE** key will store the measurement result and not the set up separately in the set up folder. You may clear the measurement results and return to the Ready-mode by pressing the EXIT key. Then you can store the current set up using the STORE button. There can be a set up folder both in the internal memory and on the optional SD-card. You use the MODE 1 SETUP 1 1 button sequence to decide where to store results and set ups.

### Mode dependent parameters

The parameters, which are not global, can be adjusted in one mode of operation for the instrument without affecting the value of the same parameters in another mode of operation. If you close a mode and return to it later, the value last used for the parameters will be automatically loaded. Please note that not all operating modes have access to the instrument set up menu. In these cases, the set up button is used for specific mode dependant functions. Please return to the Normal operating mode and adjust the instrument set up before you continue.

#### To store a measurement setup:

- Set up the instrument as required and press **STORE** *without* making a measurement. Setups are stored in a separate folder called SETUP.

### Storing a measurement

Once a measurement has been made, it can be stored in the non-volatile memory for future use, . It can be stored either in the internal memory or on the optional SD-card.

#### To store the data:

- Press the **STORE/RECORD** key after a measurement.

The data will now be stored in a folder with the name of today's date. If this folder do not exist, it will be created by the instrument. The first file gets the number 0001, the next gets the number 0002 etc. If you choose to delete one of the files already stored you will leave a gap in the file list. This gap will not be filled with a file stored later, but be left open. Otherwise, you will easily loose track of which file contains what.

When a measurement is stored, a genuine identity number (instrument ID) is also stored with the measurement results. This is not visible in the instrument itself, but post processing or measurement control software like the NorXfer or NorMonit, can be sure that the measurement results come from one specific sound level meter.

### Retrieving stored setups and data

Measurements stored are easily retrieved.

#### To retrieve a stored setup or stored data:

- 1 Press the **RECALL** key.
- 2 Select the internal (INT) or the SD-card for retrieving the data by using **INC** or **DEC**.
- 3 Follow the procedure explained in the side bar.

If you retrieved a stored setup this is now available for use, if you retrieved a stored measurement this is now available for inspection. The fact that you have retrieved something from the memory is reflected in the text line appearing at the top of the display – see Fig.

The uppermost text line in the display shows which file has been retrieved. The little R denotes Recalled, just like S denotes Stored

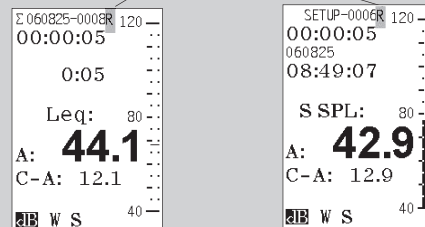

## Standard set-up

Some standard set-ups are delivered with the instrument. You may use one of these set-ups as a starting point for making your own version, or simply use them as they are. The standard set-ups are placed in a folder marked "STNDRD" in the internal memory, see figure below. A description of the different set-ups is found in the table on the next page. A short description of these different set-ups is found in the table on next page.

If a set-up for a particular mode is loaded, the instrument is automatically set to the corresponding mode of operation independent of the previous mode.

### Standard set-up

```

Recall: INT
SETUP      0006L
STNDRD     0007R
060823     0008R
060824     0009R
060825     0010R
            0011P
            0012B
            0013S
            0014F
aB W S #
    
```

### Retrieving stored setups and data

Folders      Storing device

```

Recall: INT
SETUP      0001M
STNDRD     0002M
060823     0005M
060824
060825
aB W S #
    
```

Files of selected folder

```

Recall: INT
SETUP
STNDRD
060823
060824
060825
aB W S #
    
```

```

Recall: INT
SETUP
STNDRD
060823
060824
060825
aB W S #
    
```

```

Recall: INT
SETUP      0002L
STNDRD     0004L
060823
060824
060825
aB W S #
    
```

Once you've pressed the **RECALL** key, the display will show the selected storing memory and a list of folders and the contents of one of them (here this is the folder 060825). Use the **INC** or **DEC** to select the wanted storing device. Use the vertical cursor keys to move up and down in the file list of this folder.

To be able to scroll in the folder list, press the **◀** key once and then use the vertical cursor keys to move to the required folder

For example the folder containing all the setups...

To display the files contained in the selected folder, press the **▶** key and locate the file in question by means of the vertical cursor keys.

Press **ENTER** to recall the located file/setup or **EXIT** to leave the menu without recalling any file/setup

<b>Standard set ups for the different sound level meter modes</b>	
<b>Name:</b>	<b>Description / Use:</b>
0001L	Normal sound level meter mode measurements
0002T	Normal level versus time mode measurements
0003F	Simple frequency analysis with 1/1 octave resolution
0004F	Simple frequency analysis with 1/3 octave resolution
0005M	Multi spectre frequency analysis with 1/1 octave resolution
0006M	Multi spectre frequency analysis with 1/3 octave resolution
0007R	Reverberation time measurements in 1/1 octaves with noise excitation
0008R	Reverberation time measurements in 1/3 octaves with noise excitation
0009R	Reverberation time measurements in 1/1 octaves with impulse excitation
0010R	Reverberation time measurements in 1/3 octaves with impulse excitation
0011M	Normal Mode - Annoyance recorder
0012A	Normal Mode - Audiometer calibration

---

**Note:** The reverberation time set ups 7R and 8R use excitation from the internal noise generator (option), while 9R and 10R specify impulse excitation from an external source, such as an impulse from a pistol shot or bursting paper bag.

---

## Clearing files and folders in the memory

### To delete files and folders in the directory:

- Press the clear key. The display will now produce the CLEAR menu.

In order to successfully locate the files and folders you want to load, you must apply the procedures discussed in *Retrieving stored setups and data* (including the side bar on this page).

### The menus for clearing files, folders and the entire memory

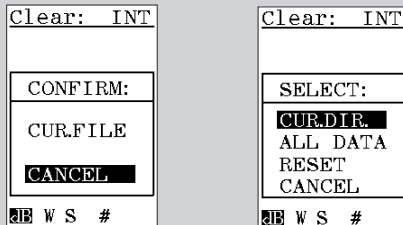

### Clearing a single file

#### To clear a single file:

- 1 Press **DEL**. Make sure that the file to be cleared is selected, i.e. highlighted (shown as white text on a black background). Press the **ENTER** key. You will now be prompted to confirm your action. However, as default the cursor is positioned on the cancel field to avoid erasing the wrong file.
- 2 Use the cursor keys to move the cursor to cur.file and press **ENTER** again. The file is now deleted.



**Keeping track of the measurement mode the file was stored in.** The different modes are indicated in the file list as follows:



All file names (i.e. file numbers) have a letter as suffix. This letter indicates the measurement mode:

- F** means frequency analysis, but no profile
- L** means that the file contains a simple global measurement, but no frequency analysis and no profile.
- M** means a multispectrum measurement
- P** means a measurement made in sound power mode.
- R** means a reverberation time measurement
- T** means a profile measurement with or without a frequency analysis (may also appear for a reverb. time measurement)
- B** means Building Acoustic measurement
- \$** means a STIPA-measurement
- f** means a FFT-analysis
- A** means an Audiometer mode measurement
- I** means an Impulse response measurement

## Clearing folders or the entire memory

### To clear a folder:

- Press **DEL**. Select it using the cursor keys and press **ENTER**. You will now be prompted to select between clearing the CUR.DIR. (i.e. the current folder or directory), all data in the entire memory or to RESET the entire memory. The option cancel is also included to avoid unintended erasures. If so, use **EXIT** to leave the menu.

If the SD-card is selected, reset is replaced by "FORMAT". Formatting the SD-card will be faster and the recommended method for clearing all data on the card.

You cannot delete the file that you are displaying. Therefore, in order to clear this file press **EXIT** before you enter the CLEAR menu.



# Automatic storing of data and noise monitoring

Due to its large memory and the high dynamic range, the Nor140 is well-suited for noise monitoring applications. Some installations, semi-permanent or permanent, are based on tight computer control, while others leave more of the job to the measuring instrument itself. The Nor140 can be used with success in both types of systems.

The Norsonic environmental solutions contain a complete range of equipment and accessories for environmental noise measurements and monitoring, all the way from outdoor microphone units, via enclosures and transmission cables to controlling and post-processing software. A detailed presentation is available at [www.norsonic.com](http://www.norsonic.com).

## Automated storage of measured data

The instrument can be set up to measure for a predefined period in time and then store the measured data. Once the data have been stored, the instrument may start to measure for another period of the same duration and then store the acquired data, start again and so on.

The snag, however, is that a little time will always be spent on storing the acquired data. This means that if

you, for example, set up the instrument to measure in periods of an hour and start the measurement exactly on the hour, the measurement period start time will exhibit a lag after some hours of measuring – typically 3–4 seconds per individual measurement.

If this lag is unacceptable for you, we recommend that you use the synchro feature. When activated, the synchro will stop the measurement slightly earlier (some seconds) to give room for data storage and housekeeping so that the measurement will start exactly on the hour.

## Available storage modes

The Nor140 will always operate in one of four available storage modes. These are:

- **Manual**, which requires that acquired data are stored manually by the operator before the next measurement is made
- **Automatic**, which causes the acquired data to be stored automatically upon measurement termination, regardless of the reason for termination – irrespective of whether termination took place because the duration expired or because you pressed stop.

- **Repeat**, which causes the instrument to store the acquired data and then restart immediately and make another measurement using the same measurement setup and duration. Repeat applies to measurements terminated by themselves only. If you terminate a measurement by pressing stop, the instrument will not restart. Note that some time will be spent on storing the acquired data, Therefore a slight delay (typically 3–4 seconds) in the restart moment will be observed.
- **Synchro**, which compensates for the time spent on housekeeping (i.e. storage of data etc.) to maintain synchronisation with the time of day. This works in the way that the instrument synchronises itself with the next full hour of the time of day. To be active, synchro requires a minimum measurement time (duration) of 30 seconds per individual measurement.

### Synchro – an example

Assume that you set up the instrument to measure in periods of one hour and that you start the measurement at 08:52:40. The first period will last 7 minutes and 20 seconds ending at 09:00:00. To give room for storage, the succeeding period will then be truncated and start a couple of seconds after 09:00:00. Each next measurement will then be a little less than an hour long to enable ending again at 10:00:00, 11:00:00 etc.

#### Going to measure very high levels?



As an optional extension the Nor140 is able to measure very high sound pressure levels without changing the microphone cartridge – see High levels in the Technical specifications for details.

A similar situation when the measurement period is set to 15 minutes will be: The first period is as before 7 minutes and 20 seconds. The following periods are all shortened so the sum of the time for measurement and storing are kept within the limit of 15 minutes. The instrument will start a new measurement period a couple of seconds after the following hour: 09:00, 09:15, 09:30, 09:45, 10:00, 10:15 etc.

We recommend limiting the use of the synchro-feature for measurement periods which are either a multiple of one hour or one hour divided by a whole number as the feature has been designed with this limitation in mind.

If you want to apply short measurement periods below a few minutes, we generally recommend using the level versus time feature, as this gives no gap in the measured levels between the different periods.



**Keyboard lockout** – locking the keyboard to prevent unauthorized operation. You may lock the keyboard to prevent the instrument from being tampered with while it is left on its own. On/off is only locked if a measurement is running.

#### To lock the keyboard:

Press **⏪, ▶, ▶, ◀** to lock the keyboard

#### To unlock a locked keyboard:

Press **◀, ▶, ▶, ⏪** to unlock the keyboard

Note that the instrument must show the sound level meter display for this to work (in this display the cursor keys are not used).

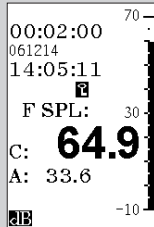
**Keyboard locked.****Setting the storage mode****To set the storage mode:**

- Press **SETUP** > **1** (Instr.) > **1** (Storing). Use the cursor keys (located below the display) to navigate in the menu as usual and set the storage mode as required by **INC** or **DEC**.
- Select the appropriate place for storing the data: either the internal memory or the optional SD-card.

**Other setup aspects**

The setup for a monitoring job will depend on the task, so no absolutes can be given here. However, you should consider such things as



**Using windscreen?** The effect of using a windshield is discussed in Windscreen in the chapter Technical specifications.

- What information will you need, and how detailed should it be?
- Measurement period length
- Profile resolution required (if applicable)
- The need for frequency analysis and bandwidth (if applicable)
- The functions to be measured
- The need for statistics (if applicable)
- The type of outdoor microphone unit (for semi-permanent or permanent installations)
- Type of calibration and microphone check.
- Adaptors needed (if applicable)
- Cabinet or casing required for the sound level meter
- Cables and cable-lengths
- External power to the instrument (batteries or mains connection)
- Type of connection to remote PC (modem, GSM modem, directly wired to the PC or maybe you will come by at regular intervals with your PC to download acquired data)

The setup of Nor140 will be found in this manual, while all accessories can be found in a separate leaflet or at [www.norsonic.com](http://www.norsonic.com).

# Making hardcopies

Measured data can be output to a printer for documentation. The instrument's print drivers support the following printer types:

- HP ThinkJet class of printers
- HP DeskJet class of printers
- Diconix range of printers
- Most numerical printers

The range of printers commercially available is an ever changing issue. Therefore what was true by the time of design of the printer drivers used in Nor140 may not be true the day you read this. Output from the Nor140 is purely numerical, hence almost any numerical printer should be able to produce the output text on the paper. The difference between the printers lies mostly in such

things as character size and width, which determines the number of characters that fit on a page.

Therefore we recommend that you make a few experiments with the setup and your printer to find the driver that produces the best-looking printouts.

Norsonic may provide a suitable cable between the instrument and the printer.

## Setting up for printouts

The setup for printouts is made in the IO/Print menu.

### To set up for printing:

- 1 Press **SETUP > 1 (Instr) > 2 (IO/Print)**.
- 2 Set the serial interface port to RS232, set a baud rate your printer can handle – be sure to use the same setting in the printer. Select the printer type as described above, and unless you're in need of printouts with German text, set language setting to ENGLISH.

Press **SETUP < 1 < 2** to produce this menu

```
IO/Print:
I face:RS232
Passw:OFF
Baud:115200
Printer:
  THINKJET
Lang:ENG.

1: DigIO
  [B]
```

## Printing out measured data

To print out measured data, be sure to visit the Prnt par menu first. This menu lets you decide which of the measured functions should be printed out. The menu comes in two flavours, depending on whether your instrument is equipped with multiple time constants or not.

**To set which functions to print out:**

- 1 Press **SETUP >1 >9 >1** (Depend on options).
- 2 Use the cursor keys to navigate and the **INC** and **DEC** keys to set the functions to be printed. A "1" means that the function will appear in the printout.
- 3 Units equipped with the enhanced profile extension allow you to select which functions to log as level vs. time. Once you've set up this table and pressed enter to put changes into effect, the instrument will prompt you to decide whether this setup shall be copied to the Prnt par. menu as well, for convenience. Note that this applies to profile printouts only.

**To start a printout:**

- 1 Set up everything as required.
- 2 Press the **PRINT** key.

For level and frequency analysis measurements the entire data set will be printed out. For profile measurements the printout will contain the periods from the present cursor position till the end of the time record.

**How to print the level, the profile and the frequency spectrum:**

- You decide what to print by what is on the display you press the print key. This means that to print the spectrum, you must display the spectrum on the screen, to print the profile you must display the profile and so on.

Two printout examples, a profile and a sound power measurement output

```

Start Date : 01:10:20      Time : 19:18:07
End Date : 01:10:20      Time : 19:18:11
Duration : 0:15          Pause : 0:00
Full Scale : 80 dB       Sens. : P=26.0dB
Time Const.: F          Period: 125 ms
    
```

Rel. Time	O	N	AF	SPL: A	Leq1	AE	Max1	C	Peak1
0:00:000				37.7	37.8	37.7			63.3
0:00:125				37.6	37.6	37.7			64.4
0:00:250				37.3	37.3	37.7			65.1
0:00:375				37.0	36.9	37.4			62.8
0:00:500				37.4	37.4	37.4			65.6
0:00:625				37.6	37.7	37.6			64.4
0:09:000				41.2	39.3	42.9			63.1
0:09:125				41.4	41.1	41.4			74.3
0:09:250				44.5	45.9	45.4			69.3

Sound Power Measurement According to ISO 3746/EN 23746		Norsonic AS	
Page 1 of 2: General Information and Overall Results			
<b>Sound source</b>			
Manufacturer:	.....	Type:	..... Ser.No: .....
Dimensions:	.....(l).....(w).....(h)	Year of manufacture:	.....
Technical data: .....			
<b>Test conditions</b>			
Operating conditions: .....			
Location of sound source in test environment: .....			
Multiple sources: .....			
<b>Acoustic environment</b>			
Test environment: .....			
Wind speed: .....			
Wind direction: .....			
Acoustical qualification of the test environment: .....			
<b>Instrumentation manufacturers</b>			
Instrument:	...Norsonic AS.....	Type: ...118...	Ser.No: .....
Preamplifier:	...Norsonic AS.....	Type: ...1201...	Ser.No: .....
Microphone:	...Norsonic AS.....	Type: ...1220...	Ser.No: .....
Windscreens:	.....	Type: .....	Characteristics: .....
Calibrator:	.....	Type: .....	Ser.No: .....
Calibration method: .....			
Calibration date:..... Place: .....			
Result: .....			
<b>Acoustical data</b>			
Measurement surface: Parallelepiped on three reflecting planes			
Reference box Length:	1.00 m		
Reference box Width:	1.00 m		
Reference box Height:	1.00 m		
Measurement distance:	1.00 m		
Measurement surface area:	21.00 m <sup>2</sup>		
A-weighted sound power:	Lw = 73.7 dB(A)		
Surface sound pressure:	60.5dB(A)		
Background noise correction K1:	0.0 dB		
Environmental correction K2:	8.50dB		
Qualification method:	.....		
Maximum C-weighted Peak:	99.1dB		
Impulsive noise:	Yes		

# Transfer of data to a PC

Different options exist for transferring data from the instrument to a personal computer (PC). The instrument may be connected to the PC by either a serial cable (RS232) or an USB-cable (USB). The quickest way however is to store the data on the SD-card and move the card to a PC for loading the data. Norsonic supply different programs for controlling the instrument and analysis of the measured data. Contact your local Norsonic distributor for more information as the number of programs is steadily growing.

For just reading the data stored in the instrument or on the SD-card, the program Nor1020 NorXfer is recommended. The program is included with the delivery of the sound level meter. The program transfers the data from the instrument to a format suitable for Windows. The data can be delivered as a text file or as an Excel workbook.

Included with the instrument is also a PC program – Virtual Instrument – which allows you to operate the sound level meter Nor140 from the PC and display a

Pin-out of the cable Nor1441, the other end is standard RS232 fitting directly into your pc.

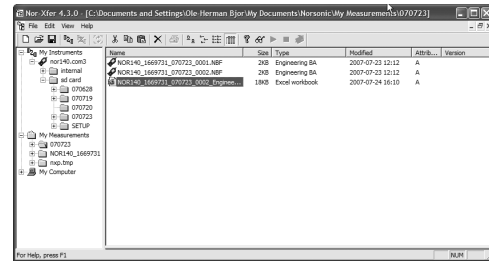
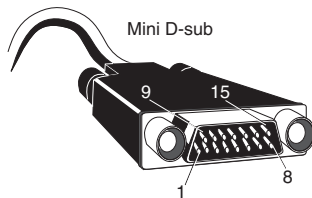

copy of the information on the instrument screen on the screen for the PC. Combined with a PC-projector this is ideal for demonstration and training. The connection to the PC can be by the serial interface or by USB.

The Nor140 is widely used for Noise Monitoring applications, both permanent and semi-permanent applications. Many of these applications is controlled by NorMonit, a program that controls the entire measurement process, by collecting data from one to many Nor140, weather stations etc. NorMonit together with NorReview forms a complete data management and reporting system for Noise monitoring. This application often requires wireless access to the instrument or communication via an IP network. Consult your local Norsonic representative for information about how to setup and configure a noise monitoring system using the Nor140.

## Select USB or serial

The selection between serial RS232 connection and USB is done by pressing **SETUP > 1 > 2**.

Select the wanted interface by **INC** or **DEC**. If serial interface (RS232) is selected, select the appropriate baud rate.

To transfer measured data from the Nor140 to a PC by serial interface you will need a Nor1441 cable (available separately, contact your local representative or the factory).

To transfer measured data via a modem, you will need a Nor1489A cable for GSM modems and Nor1490 for conventional modems. Both cables are available separately.

For the use of USB you need a standard USB cable (Nor4525 – included) and a suitable USB driver as found on the application CD accompanying the sound level meter.

A recommended way to transfer data to a PC is by means of the software program NorXfer (Nor1020). The programs NorXfer and NorVirtual Instrument are included on the CD accompanying the sound level meter. We propose that you first install NorXfer and later the NorVirtual Instrument. When you select to use USB, the PC will look for the proper driver to be installed for use by both programs.

## Password

The password feature may be turned on for providing extra safety in some applications against unwanted communication to the instrument. If this feature is switched on, all communication to the instrument on the serial and USB ports are halted until the following command is transmitted:

REMOTE\_LOGIN\_TO\_NORSONIC\_140

The communication may again be blocked by sending:

REMOTE\_LOGOUT\_FROM\_NORSONIC\_140

## NorXfer installation procedure

### Installing from the Norsonic Application CD

Insert the Norsonic Application CD.

The Autoplay feature will start the installation program directly. Just follow the instructions appearing. If problems arise, please notify us at support@norsonic.com

**NB! In Windows 7 the user will be prompted to clear the Security messages as follows:**

Click on the “Run ShelExec.exe” and the warning below will be displayed:

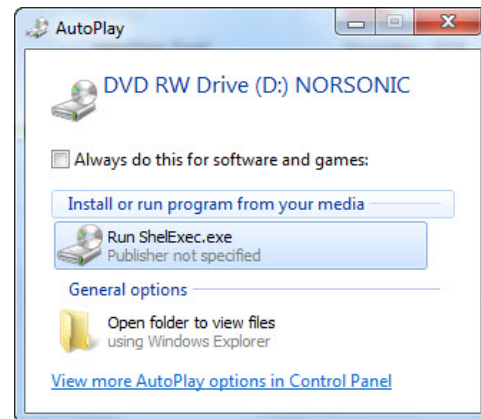

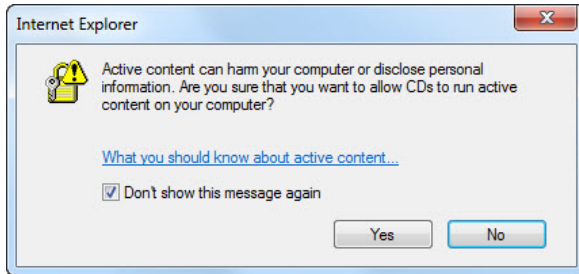

Just click “Yes” and you will proceed to the front page with the AutoPlay feature.

**PS! Under WinXp and Vista, the front page will be displayed directly.**

Select installation of NorXfer.

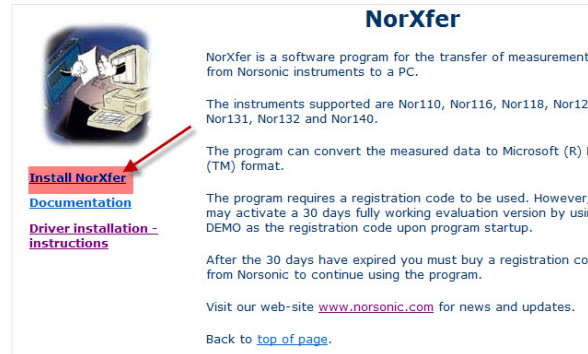
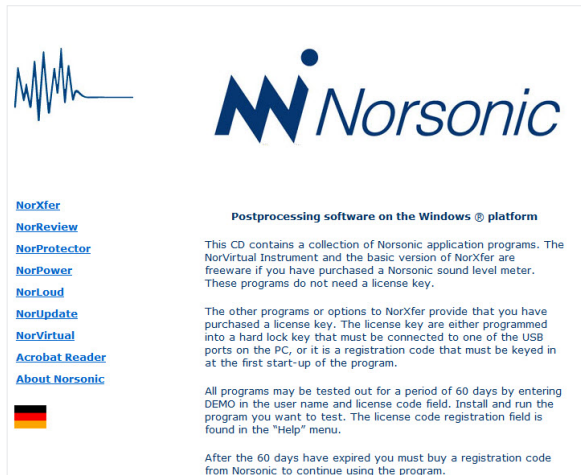

NorXfer V.5.x normally doesn't need any codes to run, unless opt.1 or 2 are installed.



**NOTE!** If this installation is an update of an existing version of NorXfer, the old version must be removed before you proceed with the installation itself. Observe that files stored in My Measurements are left unaffected by this.

For Windows 7 (default settings), there will also be a further warning before the actual installation is started, as below. Just click “Run” to continue with the installation.

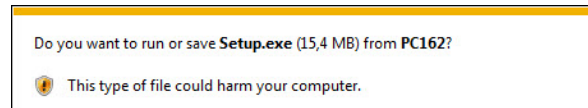

Un-installation of NorXfer V.5.x follows the normal procedure for un-installing programs in Windows.



## Installing from the Norsonic website

The NorXfer program can also be installed directly from our website [www.norsonic.com/release](http://www.norsonic.com/release). Before reaching the site where the programs resides, you will be prompted to enter information about company, name, email and product, so that we will be able to contact you if this should be necessary.

Right-click, choose “Open”, and follow the online instructions to install NorXfer:

**Norsonic instrument and PC release software site**

**Please note.** Instruments sold in Austria, Germany, Spain and Switzerland is subjected to use pattern evaluated software only. Users in these countries are requested to contact their local Norsonic representative to get the current type approved version.

**Achtung.** In Deutschland, Österreich, Spanien und der Schweiz unterliegen Schallmessgeräte einer Bauartzulassung. Die Software des Messgerätes ist Bestandteil dieser Bauartzulassung. Anwender in diesen Ländern werden gebeten, sich an den lokalen Norsonic-Vertreter zu wenden.

**Por favor,** tenga en cuenta que los instrumentos vendidos en España, Austria, Alemania y Suiza deben usarse exclusivamente con el software evaluado en el examen de modelo. Se sugiere a los usuarios de estos países que contacten con los distribuidores locales para obtener la versión aprobada en la actualidad.

**Please fill out this information before you can download any release**  
**Please fill out all the fields before downloading any release!**

Name / Firm

Email

Product

Serial number

USB drivers

- NorXfer 3.0.7.0
- NorXfer 4.0
- NorXfer 4.3.0.2 (XP/V)
- NorXfer 3.3
- NorProfile 2.0
- NorProtector 1.4.62 (XP/V)
- NorSound 2.0
- NorReview 4.0
- NorReview 3.0
- NorReview 2.0
- NorReview 1.0
- NorBuild 3.0.2.1 (W)
- NorBuild 1.2.45
- NorBuild 1.2.234
- DECT Paingo 2.0
- NorPower 2.0.74 (W)
- NorPower 1.4.64 (W)
- NorConcertControl 1.5.102
- NorVirtual 1.8
- NorImage 1.0.3 (XP/Vista)
- NorUpdate 1.5.04

## Installation of USB drivers for Nor140

Please note that you will need to install USB drivers for connecting the Norsonic instrument when communicating via the USB-port. Download drivers at [www.norsonic.com/release](http://www.norsonic.com/release).

Installation procedure for Windows 7 (32 and 64 bit).

1. Click on USB Drivers. Choose «Save as» and determine where on the PC you will save it. When the download is finished, choose “Open folder”. Rightclick on the file USB\_Drivers.zip and choose to extract the file to a known folder on the PC.
2. Power on your instrument and connect it with an USB cable (If using Nor140, remember to set it up for USB connection in the setup menu of the instrument: Press setup then 1, then 2. Use INC Button to switch between USB and RS232 )
  - a. First this message appears:



- b. After a while you see this message:



3. Then press the Windows button, rightclick on Computer and choose Properties, click on Device Manager (placed on the right side).

4. This window appears:

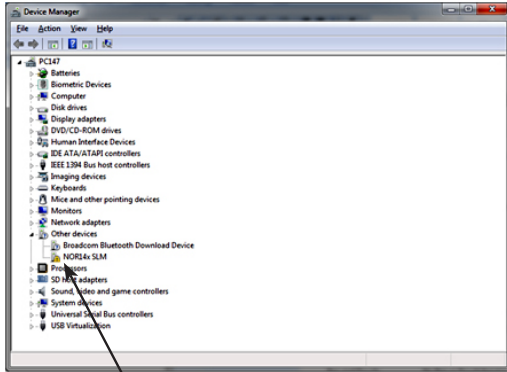

5. Rightclick on Nor14x SLM and choose Properties.

6. Click on driver pane and click on update driver.

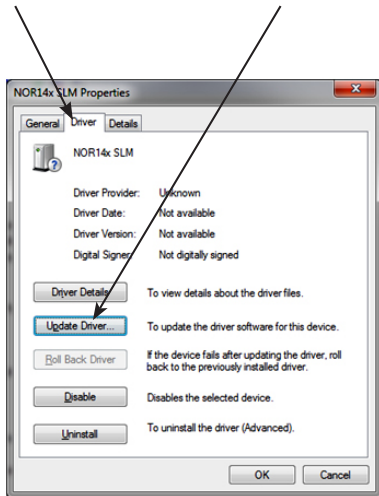

7. Click on "Browse my computer for driver software"

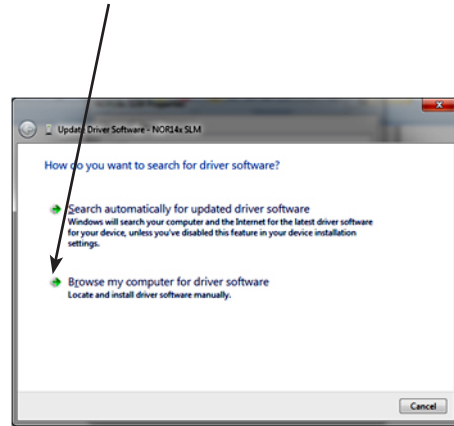

8. Click on browse and find the folder where you placed the USB drivers in step 1.

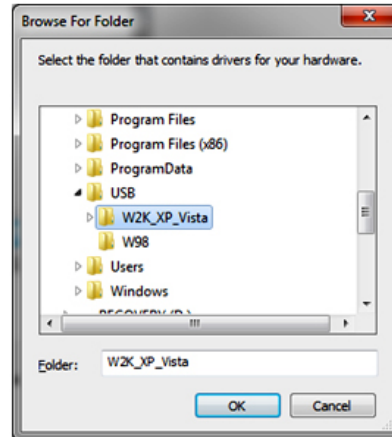

Choose the W2K\_XP\_Vista folder and click OK.

- Click Next, and a warning appears, click on “Install this driver software anyway”

If you experience problems related to the installation of the software or the driver installation, please contact your local Norsonic representative or Norsonic AS directly at [support@norsonic.com](mailto:support@norsonic.com)

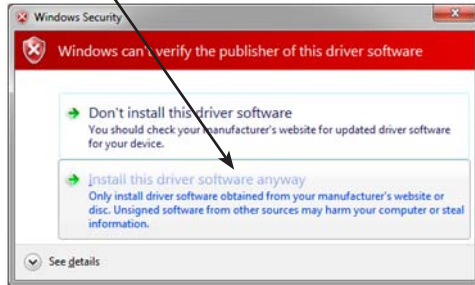

- Click Close twice.
- Back in Device manager:

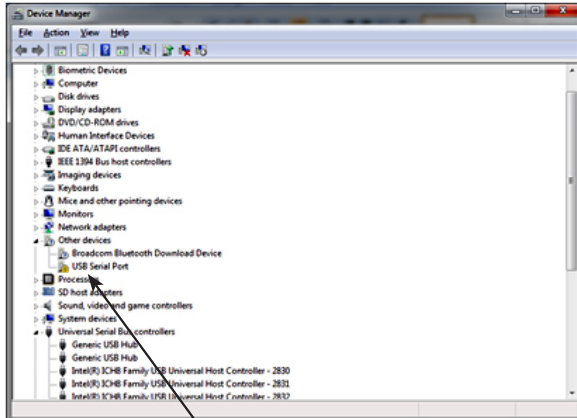

Rightclick on “USB serial port”, and repeat step 5 to 10 in this manual.

- Driver installation finished.

## Quick Reference Guide – transfer and convert a measurement to Excel

After a series of measurements are taken and stored, the files must be transferred to the PC and converted into a readable format by the NorXfer program. The program must be installed on the PC with an appropriate USB driver installed. Follow the installation procedure given when installing the program the first time. Right click on “My Instruments” and select “connect”. The menu below appears. Select either “local (SD card) (Nor140) or the appropriate USB port (Nor13x and Nor140), dependent on where the data is stored

The instrument will appear as shown below. Double-click on the instrument in the right frame to expand the file folder.

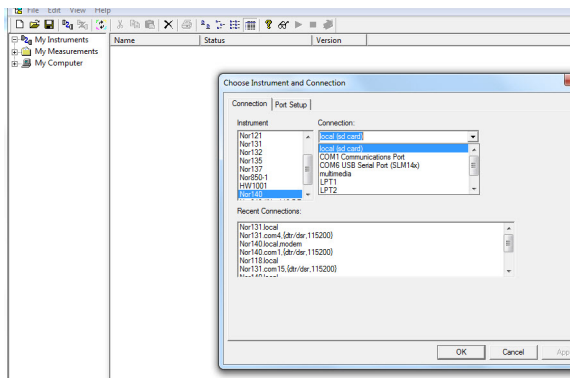

Mark the measurement files that you want to copy onto the PC. Use drag and drop to the “My measurements” folder or right click and select “send to My Measurements”

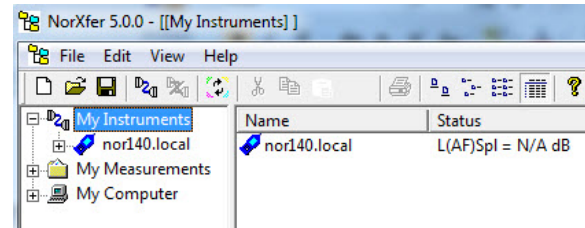

Expand “My Measurement” folder and select the right subfolder and catalogue. Select the measurement files and right click. Select “Overview (Excel)”. The Overview configuration menu appears. “Use only actual function in file(s)” checkbox and select the OK button.

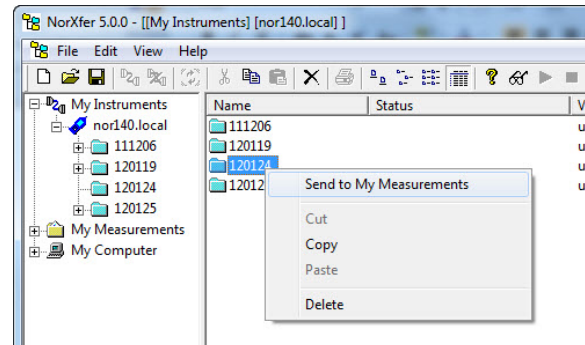



## Virtual Instrument – Nor1036 Installation procedure

Load the application CD and select install Virtual instrument. Follow the procedure given by the installation program.

## Using Virtual Instrument Nor1036

Connect the instrument to the PC and select the serial or the USB interface as appropriate by pressing **SETUP > 1 > 2**.

Start the program Virtual instrument Nor1036. The program will automatically start to look for the instrument. This may take some time. The screen below will be shown when the program is running. A copy of the instrument display is shown adjacent to picture of the keyboard for the instrument. You can operate the instrument as usual by pointing on the appropriate key with the PC-mouse and click with the left-hand mouse-button.

If you have more instruments connected, select the wanted unit in the menu “Connections”.

You may store a digital copy of screen by pressing “Snapshot”. The setup for the picture format and where to store the picture is found in the “File” menu. The figure below shows the setup. The screen picture may be stored as Bitmap (bmp), Jpeg or Tiff. The Tiff-format is reversed: white text on black background.

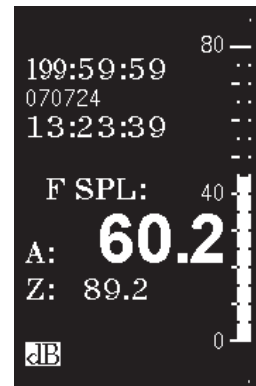
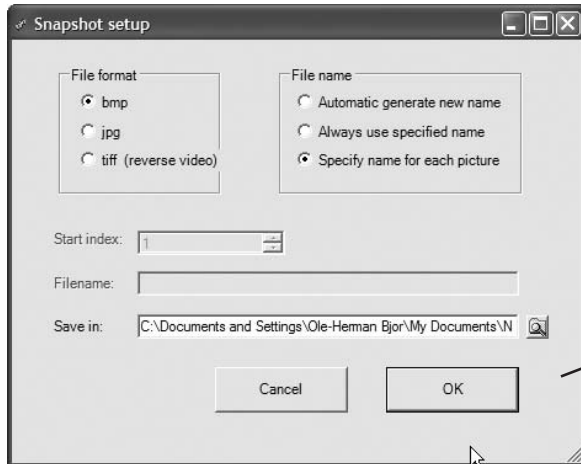
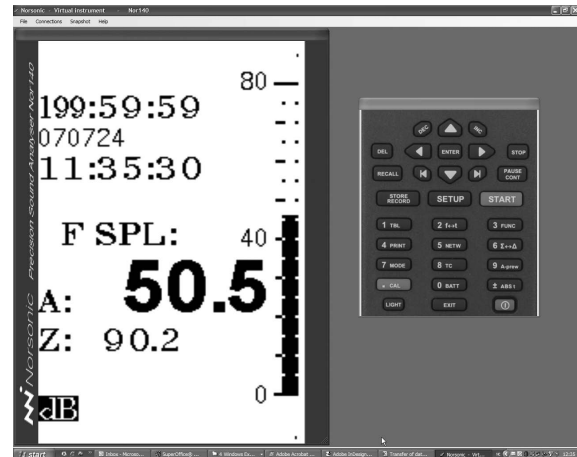

# Signal input and output

## Signal input

The socket for signal to measure is the normal microphone input socket of the Lemo type. See the section Technical specifications for detailed information. The socket supply polarisation voltage and power to the preamplifier.

The signal input is at pin 4 with the ground reference on pin 2. Pin 2 is connected to the outer shield for the connector, but it is recommended to separate the shield from the signal reference since the instrument has a very low self noise and ground currents can easily destroy low level signals in the microvolt range.

When you select the standard preamplifier by pressing **SETUP > 1 > 4** (Press **INC** if “STANDARD” is not displayed), the signal input is an AC-coupled input terminal with an input impedance of more than 600 k $\Omega$ . This mode is used when the ordinary preamplifier Nor1209 is applied.

The signal terminal may also be used for more general applications as for measuring the AC-voltage from other transducers or sources. The measurement range is from  $\pm 10$  volt peak to levels less than a microvolt

– dependent of the applied frequency weighting. The cable Nor1438 with a BNC connector in the far end may be convenient for such applications.

In this case you should set the input from **STANDARD** to **LINE**.

## IEPE

The input terminal pin 4 may also supply current to transducers of the constant current or IEPE-type. This mode is selected by pressing **SETUP > 1 > 4** and toggle the input to IEPE. A current of 3 mA from a 25 volt power source will then be supplied to a connected transducer. These types of transducers are often used for measurement of acceleration. Nor140 is able to measure down to 0,4 Hz, and will therefore be well suited for such applications.

If you need a very long extension cable between the microphone and the instrument, you should consider the Nor1207 IEPE-type of preamplifier. This will allow a one-conductor, screened cable to be used. Nor1207 may be delivered with either BNC or TNC output connector.

A detailed description of the input menu is given on page 15.

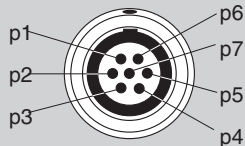

### Noise output

The signal is available on the general I/O socket. See the sections Noise generator and Technical specifications.

### RPM

The instrument is equipped with an input for tachometer signals marked RPM, on the right hand side of the instrument. The RPM functions are turned on and off via the **SETUP 9** selection.

### Signal output

The sound level meter Nor140 is equipped with a signal out terminal. The signal is a replica of the microphone- or input signal. You may use the terminal for listening to the measured signal, or you may use it for other purposes.

The signal output gain is set via the selection of displayed full scale. Full scale on the display corresponds to 100 mV on the signal out terminal. Although the selection of full scale will not affect the measurement, it will determine the sensitivity for the signal out. Use the **INC** and **DEC** keys to adjust the gain. The gain may be varied over a range of 60 dB in 10 dB steps.

The signal out terminal can drive loads with impedance down to less than 16 ohm, but we normally recommend a headset with 32 ohm impedance. Even



#### Use a stereo plug!

Never use a mono plug for the signal output jack as this will short-circuit one of the outputs. Although it will not destroy the instrument, the power consumption will increase



#### Jack-plug for signal out

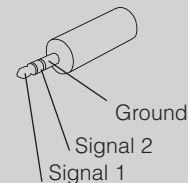

a short-circuit will not affect the measurements, but should be avoided due to an excess power consumption.

The signal output terminal is a 3,5 mm stereo-jack compatible with most headphones. Both channels have the same signal, but are driven from separate amplifiers and should therefore not be connected together.



# Trigger

## General

Noise monitoring often requires operating a sound level meter out in the field for unattended long-term measurements. The trigger option (option 16) allows the measurement to start when a selected condition is satisfied. The condition may be:

- A certain time of the day
- An externally supplied trigger signal is activated
- Level is above a specified threshold

By using the clock trigger, a measurement may be started at a specified time of the night even if the instrument is set up during daytime. The result may be stored automatically, the instrument can be picked up later and the results downloaded.

By setting the storing option to “Repeat” a measurement may be started automatically each day at the same time. Ensure that the measurement time is selected so the measurement is terminated before a new trigger condition is satisfied.



### Triggering a sound record

The triggering of sound records are covered in the section “*Recording the sound*”.

The measurement may also be initialised by a trigger signal from an external device. When started, the measurement will last as long as set up by the measurement duration parameter. By using the storing option “Repeat”, a new measurement may be started by a new trigger signal after the first is finished.

The external trigger option may be used for synchronising more sound level meters.

An often-used trigger function is the threshold trigger, which starts a measurement as soon as the noise level exceeds a pre-defined level. Used in combination with the repeat function and automatic storing of the result, the sound level meter may unattended store a number of noise events for later analysis.

The triggering of sound records are covered in the section “*Recording the sound*”.

### Setup menu

```

SETUP:
1: Instrument menu
2: Meas. duration
3: L(t) params
4: Frequency mode
5: Level range
6: Trigger
7: Noise gen.
8: Recording
9: Reference tone
  
```

BRWGS #

### Trigger menu

```

Trigger:
1: Meas.
2: Record
  
```

BRWGS #

## Setting the trigger condition

When the instrument is installed with the trigger option, the Trigger Menu is found in the Setup menu. Press **SETUP** and **6** for “Trigger” and press **1** for measurement trigger. The first four lines in the menu allow you to select the function for triggering. The last line allows you to set the parameters associated with the selected function.

Use the **▼▲** cursor keys below the display to select the desired trigger function. Press **ENTER** to confirm the selection.

### Manual trigger

When MANUAL trigger is selected, the measurement will start immediately after the **START** key is pressed. This corresponds to the way of operation before the trigger option was installed.

### Clock trigger

Move the field cursor to “Clock”, and then press **1** to select the menu for setting the time for starting the measurement. The display below will be shown. Use the **◀▶** cursor keys to select the field for hour, minutes

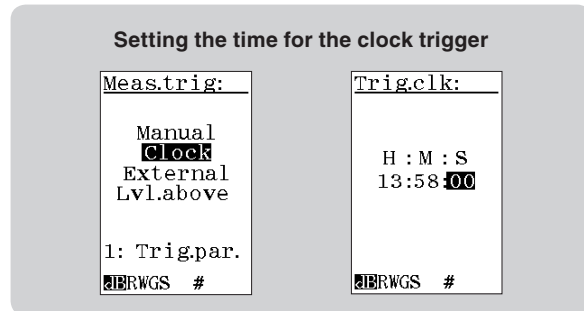

or seconds. Modify the value by using the **INC** and **DEC** key on the right side of the display, or key in a numeric value followed by pressing **ENTER**. When the required time is set, press **ENTER** twice for leaving the menus.

For making a measurement, press the **START** key. A “Wait-indicator”



will be shown in the display instead of the “Run-indicator”. When the displayed time of the day as indicated by the clock in the instrument coincides with the triggering time, a measurement will be automatically started.

If you want to interrupt a waiting-for-trigger operation, press the **STOP** key.

If you set the repeat measurement/store function (Press **SETUP > 1 > 1**), the instrument will start a new measurement after the first is finished and wait for the trigger condition to be satisfied again. This will occur at the same clock the following day. In this way, you may start a measurement at the same time every day. The duration and time resolution of the measurement are set as usual.

Alternatively, if you set the synchro measurement/store function (Press **SETUP > 1 > 1**), the instrument will start a measurement at the pre-selected time, store the result and start a new measurement. The duration of the measurement will be as selected, but adjusted so the start of the periods are synchronised with the change of the hour for the real-time clock in the instrument. Example: A measurement with a duration of ½ hour is started 09:40. The first period will end in due time to start the next measurements 10:00, 10:30, 11:00 etc.

## External trigger

The external trigger function is selected by moving the field cursor to the field “External” and pressing **ENTER**.

After pressing the **START** key, the instrument will start waiting for an externally supplied binary voltage signal (3,3 volt CMOS). The signal has to be applied to DI-1, pin no 8 on the general I/O-socket. See the specification section for further information.

The remote hand switch Nor263A is designed for external trigger of either remote start of the measurement process or remote start of an audio recording. The trigger conditions is set in the trigger menu; **SETUP > 6**. After selecting the trigger condition the digital IO must be configured to use the remote hand switch Nor263A. You may skip the configuration, since the push button will work regardless of the setting. However, to achieve proper operation of feedback LED mounted on the handswitch, you need to set this in the digital IO menu. Push **SETUP > 1** (Instrument menu) > **2** (IO / Print) > **1** (Digital I/O). The LED is connected to DO-1. Please note that the QC (Quality Control) function in the Reference Curve menu **SETUP > 4** (Freq mode) > **1** (Reference curve) must be turned off, unless is DO-1 and DO-2 reserved for the QC function.

Select DO-1 to RUN if you use the hand switch to start a measurement or to **REC** if you use the hand switch to start an audio recording.

If you set the repeat measurement function (Press **SETUP > 1 > 1**), the instrument will start a new measurement after the first is finished and wait for the trigger condition to be satisfied again.

If you want to interrupt a waiting-for-trigger operation, press the **STOP** key.

## Level above-trigger

The level above-trigger function allows a measurement to be started as soon as the level in the specified network or filter band is above a specified threshold. In this way, a noise event may initiate a measurement. The duration and time resolution of the measurement are set as usual. The selected main time constant, F, S or I, is used for the level triggering function.

Move the field cursor to the field “Lvl.above” as shown on the figure and press **1** for selecting the threshold. A menu as shown on the right is displayed. The field below “Threshld:” indicates the sound pressure level needed for triggering. Modify the value by using the **INC** and **DEC** key on the right side of the display, or key in a numeric value followed by pressing **ENTER**.

When the required level is set, move the field cursor to the field below “Freq/netw:”. Select the required frequency band or network by using the **INC** and **DEC** key on the right side of the display. The networks may be selected by scrolling above the highest frequency band.

Press **ENTER** repeatedly until the main measurement display appears.

For making a measurement, press the **START** key. A “Wait-indicator”



will be shown in the display instead of the “Run-indicator”. As soon as the level comes above the threshold, the measurement is automatically started.

If you set the repeat measurement function (Press **SETUP** > **1** > **1**), the instrument will start a new measurement after the first is finished and wait for the trigger condition to be satisfied again.

If you want to interrupt a waiting-for-trigger operation, press the **STOP** key.

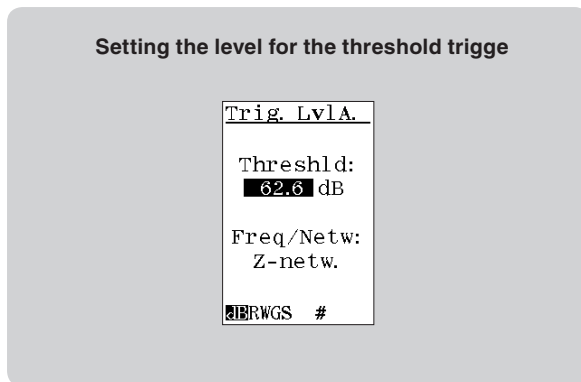

# Recording the sound

The Nor140 instrument allows storing the sound signal itself obtained by the microphone if the appropriate option 8 is installed. The most common application is for identification purposes (by listening to the sound signal). Dependent on the selected quality of the selected storing format, the signal may also be used for further analysis.

The recording quality is available in several flavours serving slightly different purposes. The main disadvantage for using an unnecessary high quality is large files which consumes a large part of the storing medium and the need for a longer time for handling.

## Formats

Three different word lengths, 8 – 16 – 24 bit, and two sampling frequencies, 12 kHz and 48 kHz, give in total 6 different formats for the recorded sound. A sampling frequency of 48 kHz is equal to the native sampling frequency for the instrument and corresponds to the full frequency range for the instrument (about 23 kHz). When combined with 24 bit resolution, the format reflects the basic accuracy of the instrument and should be used if further processing of the signal is requested. When the sampling frequency is set to 12 kHz, only frequencies up to 5 kHz can be reproduced. However, in most cases this is sufficient for noise source iden-

tification. Note that the best format consumes twelve times as much memory as the simplest for storing a recording with a certain duration.

## Recording gain

The Nor140 has a large dynamic range – exceeding 120 dB. This means that if you try to play back the recorded sound after having transferred the files to your PC, you will – in most cases – hear nothing! The reason why is that most soundcard/PC solutions simply can't handle the high dynamic range. To overcome this problem you may introduce a gain applied to the recorded sound only – the rest of the measurement is left unaffected. The drawback is that the dynamic range for the recording is reduced accordingly so a sound recording overload may occur with no overload being detected by the instrument. All other parts of the measurement are left unaffected by this gain setting.

The upper range for the recording will be the upper level for the instrument minus the selected recorder gain. The upper range for the instrument is dependent of the calibration, but is normally 130 dB (140 dB peak). The recording gain may be selected in steps of 6 dB (2x) from 0 dB to 96 dB. Enter a numeric value or use **INC** or **DEC**.

## Recording duration

The duration of a recording can be set from 1s in one second steps up to 9999 s (close to three hours). If the duration is set to 0, the record length will have no limit. This means that the record will last to the end of the measurement or until the storing device is filled.

Note that for event triggered recordings, the specified duration will indicate the maximum duration – the duration will otherwise be set by the condition for triggering.

## Making a recording

The start of a recording may either be done manually by pressing the **RECORD** key or if trigger option is installed, by supplying an external trigger signal (as from a remote button) or based on a noise event detected by the instrument. If the trigger option is not installed, only the manual start of the recording without any delay is available.

For a level triggered recording the recording will start during a measurement if the level in the selected network or filter band exceeds the preset level. The length of the recording is selected as a part of the setup.

From the trigger menu, the delay in starting the sound recording can be set from -99 seconds up to

99 seconds. This allows the recording to start up to 99 seconds *before* you pressed the record button or the trigger condition was fulfilled.

The recording file is automatically assigned to the current measurement. When the level versus time display is selected, the time for the recording will be marked adjacent to the time axes. See figure below. The audio file itself can not be seen in the Recall function picture. You can use the program NorXfer to transfer the files to your PC for further examination or analysis.



Please note that use of pre-trigger (negative trigger delay) of more than 5 seconds (-6s to -99s) in reality means that the instrument is storing the audio recording file continuously in order to be prepared for any possible audio trigger. This may bring the internal processor up to its maximum capacity which then will result in slow update of the display screen or in extreme cases even an automatic turn-off of the recording in case of a processor work overload (marked with a W in the display).

If this problem occurs with the current setting, the user may reduce the processor capacity by altering any of the following settings:

- Reduce the audio recording quality (8 or 16 bit instead of 24 bit, 12kHz sampling instead of 48kHz)
- Avoid use of large capacity SD-cards (remember that several small SD-cards is safer than only one large SD-card)
- Limit the audio recording pre-trigger (negative trigger delay) to less than 6 seconds (-5s to 99s)
- Limit the number of selected L(t) parameters
- Increase the selected level vs. time profile resolution
- Avoid use of the Pause/Cont feature

Recording mark

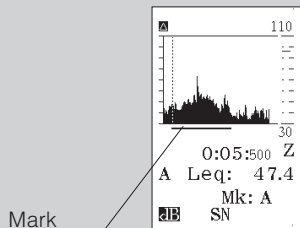

## Setup for a recording

Press **SETUP** > **8** and menu for specifying the recording will be shown.

Select the duration for each recording in seconds. Enter a value in the range 0 to 9999 seconds by keying in the value or by using **INC** or **DEC** to modify the displayed value. The value 0 is used for selecting a recording which lasts to the end of the measurement.

Select the required format for the recording by selecting the number of bits and appropriate sampling frequency. All recordings are made in a standardised WAV-format which allows most media-players to play the recorded file.

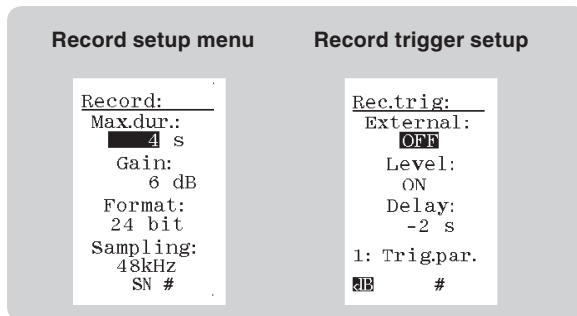

## Setup how to start a recording

A press on **STORE/RECORD** will start a recording with the selected duration.

If the trigger option is installed (Option 16), triggering from an external signal or from a noise event is also viable. Press **SETUP** > **6** for triggering and then select **2** for record triggering. You have to select between the following alternatives:

### Manual trigger

Set the external and level triggering to “OFF”. Select the time delay between the trigger command and the execution. A value in the range -99 to 99 may be used. -99 means that the record starts 99 seconds before **RECORD** was pressed. Note that a measurement has to be running before you are allowed to store a record! Key in the value or use **INC** or **DEC** to modify the displayed value.

### External trigger

Set External to “ON” by the use of the **INC** or **DEC** keys if you want to enable triggering by an external signal to the digital input terminal. After pressing the **START** key, the instrument will start waiting for an externally supplied binary voltage signal (3,3 volt CMOS). The signal has to be applied to DI-1, pin no 8 on the general I/O-socket. See the specification section for further information.

The remote hand switch Nor263A is designed for external trigger of either remote start of the measurement process or remote start of an audio recording. The trigger conditions is set in the trigger menu; **SETUP** > **6**. After selecting the trigger condition the digital IO must be configured to use the remote hand switch Nor263A. You may skip the configuration, since the push button will work regardless of the setting. However, to achieve proper operation of feedback LED mounted on the handswitch, you need to set this in the digital IO menu. Push **SETUP** > **1** (Instrument menu) > **2** (IO / Print) > **1** (Digital I/O). The LED is connected to DO-1. Please note that the QC (Quality Control) function in the Reference Curve menu **SETUP** > **4** (Freq mode) > **1** (Reference curve) must be turned off, unless is DO-1 and DO-2 reserved for the QC function.

Select DO-1 to RUN if you use the hand switch to start a measurement or to **REC** if you use the hand switch to start an audio recording.

### Level above-trigger

Set the level triggering "ON" by the use of the **INC** or **DEC** keys if you want to enable triggering by a level. A record of the sound will be started as soon as the level in the specified network or filter band is above a specified threshold. In this way, a noise event may initiate a record. The selected main time constant, F, S or I, is used for the level triggering function. While the cursor is on the field for level triggering, press **1** for setting the level and frequency weighting for the trigger point. The field below "Threshold:" indicates the sound pressure level needed for triggering. Modify the value by using

the **INC** and **DEC** key on the right side of the display, or key in a numeric value followed by pressing **ENTER**. The frequency weighting may be one of the bandpass filters if the filter option is installed. Use **INC** or **DEC** to modify the displayed value.

After pressing the **START** key, the instrument will start a record the selected delay after the level goes above the threshold. If a negative value has been entered for the delay, the record will start the specified number of seconds before the triggering condition was fulfilled. The minimum duration the level must stay below the threshold before the record is terminated is 3 seconds. Therefore the record will last three seconds after the trigger condition is no longer fulfilled or until the selected duration has exceeded. Note that a new event has to occur before a new record is started. (The level has to cross the threshold from below).

A new record can not be started before 5 seconds after the termination of the previous.

If you want to make an automatic record lasting for the whole measurement, set a very low threshold (e.g.: -19,9 dB) and select the duration to 0 s.

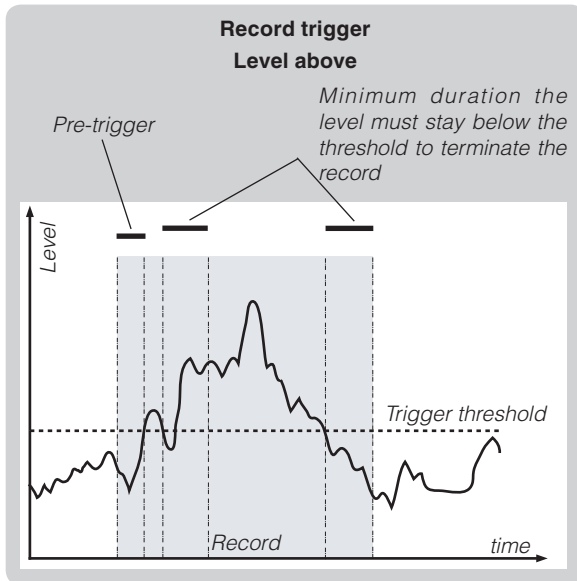

### Listening

For listening to the recorded sound we recommend to transfer the file to a PC. This may be done by transferring the measurement data with the recording to a PC or by storing on the SD-card and plugging the card in a card reader. In both cases we recommend to use the program NorXfer (Nor1020) for taking care of the menu structure. When the result is analysed with the PC-program NorReview (Nor1026) the measurement and the sound recordings are automatically coupled. Please contact your Norsonic representative for further information.



## Insert a reference tone as a recording

When listening to a recording, it may be required to make the playback with the same actual sound level at the listener's ears as the original sound was at the spot of the actual measurement. In such cases a reference tone with a pre-defined level may be recorded during the measurement, and later replayed through the listener's loudspeaker system at the spot of the replay. The reference tone is activated by use of the **CAL** key during a running measurement provided that it has been enabled in the Ref.tone menu. The menu is displayed by pushing **SETUP > 1 (Instr.) > 8 (Ref.tone)**. The reference tone feature is enabled by using the cursor keys to move the cursor to the upper position and selecting "ON" using the **INC** or **DEC** keys.

```

Ref. tone:
Ref.tone:
      ON
Type:SINE
Gain:-20 dB
Ex.time: 10
Freq 1.0kHz

      SN #
  
```

The preset type, gain and excitation time of the reference tone are edited in the same menu. The type is either PINK noise or a SINE wave. If the SINE is selected, the actual frequency is set at the lower cursor position. The default level of the reference tone is 120 dB. This may be lowered by choosing a gain between 0 and -50 dB; hence producing a reference tone in the 70 – 120 dB range. The excitation time, or duration, of the reference tone after activation by the **CAL** key is also selected in this menu. The duration is variable within the 1 – 60 second range.

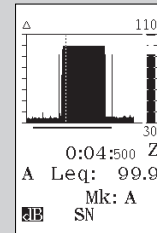

# Reference Spectrum

## General

The Reference Spectra feature is used for comparison of any measured frequency spectrum with a pre-selected user defined spectrum. It functions both on 1/1-octave and 1/3-octave spectra.

The measured spectrum may be compared to an upper limit, a lower limit, or both an upper and a lower based on user defined boundary spectra. If the measured spectrum exceeds the boundaries, a “NoGo” warning may be given.

The Reference Spectra features will be available when option 2 is installed. This option requires that option 1 (1/1-octave filters) is present.

## Activating the Reference Spectrum features

The Reference Spectrum features are controlled from the sub menu 1 in the Frequency mode menu. The basic requirement is that the Freq. Mode is turned On in the upper part of the menu.

In the Ref. curve menu, either the Upper or the Lower, or both, must be turned On. These selection will turn on the currently stored upper and/or lower Reference Spectra in the graphical level vs. frequency display. This menu is opened by first moving the field cur-

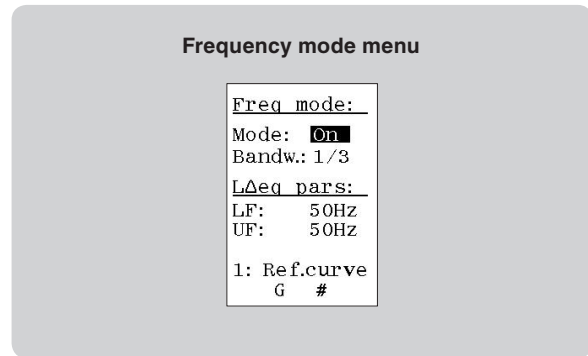

sor into the lower part of the Freq. Mode menu, and then using the **1** key to open the Reference parameter menu.

The upper and/or lower spectra are displayed using short lines for each individual frequency band. The lines are of XOR type which means the lines will always be visible both with and without the actual overlaid bar-graph. See the figures on next page which shows examples with only the upper 1/1-octave and with both upper and lower 1/3-octave Reference Spectra activated.

## Selecting the Reference Spectra

Selection and/or editing of the individual Reference Spectra are done in the Ref.curve menu.

**Reference curve selection menu.**

```

Ref.curve:
Upper: Off
Lower: Off
QC: On
Delay: 99s
1: Upper1/1
2: Lower1/1
3: Upper1/3
4: Lower1/3
G #

```

**Upper 1/1-octave reference spectrum**

```

Upper 1/1
X-oct  Leq
8.0Hz  -.-
16Hz   -.-
31.5Hz -.-
63Hz   70.0
125Hz  73.0
250Hz  76.0
500Hz  79.0
1.0k Hz 82.0
2.0k Hz 81.0
dBWGS #

```

Four Reference curves (or spectra) are stored within the instrument:

- 1: Upper 1/1-octave spectrum
- 2: Lower 1/1-octave spectrum
- 3: Upper 1/3-octave spectrum
- 4: Lower 1/3-octave spectrum

Choose the desired Reference Spectrum by use of the numerical keys **1** – **4**. A table will be presented containing either empty values for each frequency band, or, the previously used values for each frequency band. The individual values may be viewed by scrolling downwards, and values for A-, C- and Z-weighting networks are available at the lower end of the table.

## Using a previously measured spectrum

Select one of the four possible Reference curves as indicated above, press the **RECALL** key and use the normal memory operation to choose any previously saved measurement as the new Reference Spectrum. By confirming the selection with the **ENTER** key, the stored Leq values from the selected spectrum will be entered as the new Reference Spectrum.

In case a measured 1/3-octave spectrum is chosen as a Reference Spectrum for a 1/1-octave comparison, the 1/3-octave spectrum will be re-calculated into a 1/1-octave spectrum automatically. Choosing a previously measured 1/1-octave spectrum for a 1/3-octave comparison will produce an error message ("File data has wrong bandwidth").

## Entering a new Reference Spectrum manually

Select one of the four possible Reference curves as indicated above, use cursor keys to move the field indicator to the first desired frequency band, and key-in the correct value for this band using the numerical keys. Use the cursor keys to move the field indicator to the next frequency band and key-in the desired value for this new band. Continue this operation until all desired frequency bands are entered.

It is **NOT** required to enter values for all bands. Only those bands which have a value entered will be displayed on the graph. Hence, the user has full control of which frequency bands of the Reference Spectra that should be visible.

## Editing a selected Reference Spectrum

Use cursor keys to move the field indicator in row with the frequency band to be edited. Use the **INC** and **DEC** keys to adjust the value (in 0.1 dB steps) or use the numerical keys to enter the desired new value. Alternatively, use the **DEL** key to clear the value.

If the values from one or more bands are deleted, the Reference Spectrum indicators for these bands are **NOT** presented in the graphical display.

### Comparison between reference and measured spectrum. A-preview is selected

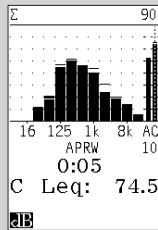

## A-pre-weighted Reference Spectrum

The Reference Spectra saved in the instrument are always stored as unweighted values. However, if the A-pre-weighting display feature is used during the comparison, both the displayed Reference Spectrum and the measured frequency spectrum will be pre-weighted.

## “Go / NoGo” Quality Control feature

The Reference Spectrum feature may be used to give a “Go” or a “NoGo” output signal in quality control applications. This additional feature is found in Ref. curve (**SETUP 4 > 1**) menu as the “QC” setting.

There are three selections for the QC feature:

- Off: No “Go / NoGo” comparisons are made
- On: The “Go / NoGo” comparisons functions continuously before, during and after the measurement. When selected On, a sub menu appears, where you may select a **Delay**. This delay will hold the Go/NoGo comparison signal on the digital I/O active the number of second that is entered. Any value between 0 and 99 seconds is accepted. This feature is especially useful when an alarm lamp or other type of warning device is connected to the instrument. The alarm will then stay on as long as the signal is outside the reference spectra plus the number of seconds entered in the **Delay** field.
- End: The “Go / NoGo” comparisons functions only after the measurement has been ended or stopped

The status of the “Go / NoGo” comparison is displayed as a “Go” or a “NoGo” symbol within the L(f) display. As the Reference Spectra only contain dB-values, the currently selected spectra function (Leq, Lmax, Lmin, etc selected by the **FUNC** key) will be the basis for the comparison of the actual measurement spectrum with the currently stored and selected Reference Spectra. All frequency band values of the actual measured spectrum must fulfil the actual requirements of the saved Reference Spectra in order to get a “Go” status.

In cases where all frequency bands must be above or below the Reference Spectrum in order to get the desired “Go/NoGo” status, a selection of the respectively Lower or Upper Reference Spectrum as limits will perform the required operation. Alternatively, selecting both the upper and lower Reference Spectra requires that the measured spectrum must be between these two Reference Spectra for all frequency bands that contain values.

### Digital output lines

One of the digital output lines of the I/O socket may be set to follow the “Go / NoGo” status. Hence, this output pin goes high when any frequency band within the measured spectra is above the upper reference spectra or below the lower Reference Spectra. If only one of the Reference Spectra is activated, only this spectrum is considered for the digital output status. See setup of digital I/O

A digital output line of the I/O socket may be set to go high when the instrument is busy taking a new measurement (i.e. in “Running” or “Ended/Stopped”) and until the instrument is ready to take a new measurement (i.e. entering the “Waiting for trigger” mode again).

As an example you may select the following:

- Pin 1 = Low (0)    Waiting for trigger to the next measurement
- Pin 1 = High (1)    Busy with an ongoing measurement
- Pin 2 = Low (0)    Status “NoGo”
- Pin 2 = High (1)    Status “Go”



**Note!** When using the relay box Nor268, Digital I/O 2, DO-2 must be set to GO in the Digital I/O menu - **SETUP 1 > 2 > 1.**

### 1/3-octave analysis with upper and lower reference spectra activated.

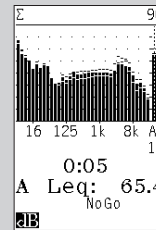

### Digital IO

Digital IO:	
DO-1:	OFF
DO-2:	GO
DO-3:	OFF
DO-4:	OFF
G	

# Noise Generator

## General

By activating option 10, access to an internal signal generator is gained. Dependant on the selected operating mode, several types of signals are available.

The generator signal is available on pin 15 on the general I/O socket. Matching cables with BNC connectors for the noise output are available under part numbers Nor4513A and Nor4514A.

The option 10 allows noise excitation to be used for measurement of reverberation time if the instrument is equipped with option 9 – Reverberation and for measurement of airborne sound insulation (Option 11).

Note that the contents in each menu will depend on the options installed.



**Note!** Use cable Nor4513A and Nor4514A, Cables Nor4513 and Nor4514, designed for use with the sound level meter Nor118, shall not be used since these cables will keep the terminal for external reset permanently low.

## Selecting noise type and level

Press **SETUP** and either **3** or **7** (dependant on operating mode) for selecting noise set-up menu. A dialogue box as shown in the adjacent figure will be shown. Use the arrow buttons below the display to move the field cursor. Use the **INC** and **DEC** key to change the content. The gain may be entered as a numeric value. Press **ENTER** to terminate a key-in operation.

- “**Gen**” switches the signal generator on/off.
- If “**Sync**” is on and “**Gen**” is off, the signal will be switched on when a measurement starts and be switched off after the measurement is ended. This is used for reverberation time measurement with noise excitation.
- The noise type may be selected white or pink. A pink noise will have similar levels in all fractional-octave bands within the main frequency range for the generator (16 Hz – 20 kHz).
- Gain is used for setting the signal level. The figure indicates dB relative to 1 volt for the broadband signal.

Press **ENTER** to leave the menu after set-up

## Adjustments for reverberation measurement

When the instrument is equipped with option for measuring reverberation time (Option 9), the noise generator may be used for the excitation. The setup is done in the Reverberation control menu as shown on the figure.

- The excitation type (Ex.type) may be selected impulse (IMP) or noise (NOS).
- The Excitation time (Ex.time) indicates number of seconds for the noise excitation.

For measuring reverberation with noise excitation, the generator must be set to OFF and synchronisation to ON in order to allow the generator to be switched on and off correctly.

## Standard Set Up

Each operating mode of the instrument has a set of default parameters that will be put into use the first time an operating mode is selected. The Noise generator set up is a part of several “Standard Set Ups” or default function selections. These set ups can also be recalled later at any time from the “Standard Set Up” directory. See the section “Memory Handling” earlier in this instruction manual.

## Equalization of the noise spectrum

Some times it is desirable to have a frequency flat excitation signal, but that can be difficult due to acoustical properties and frequency response of the excitation equipment. For this purpose an equalizer can be connected in the noise generator. The equaliser is “self adjusting”. In the Noise generator set up menu there is a selection called “Equal:”. When this is set to ON, a

new line “Adj. Equal.” appears. You can move the cursor to this line and press enter. The noise is then turned on and a spectre measurement is performed. After the measurement is terminated, the relative response from this measurement is fed into the equalizer. This equalizer has a dynamic range of 12 dB which it tries to use for this frequency response optimisation.

Using the on/off setting will then activate/deactivate the equalizer. The equalizer is not active in reverberation measurement.

### Setup menu

```

Noise ctrl:
Gen: OFF
Sync: ON
Type: PINK
Gain: -10 dB
Equal: OFF

SN
  
```

### Noise control setup up Equalization

```

Noise ctrl:
Gen: OFF
Sync: ON
Type: PINK
Gain: -10 dB
Equal: ON
Adj. equal.

N
  
```

# Compensation and correction

## General

Sometimes the accuracy of a measurement can be increased if the measurement is corrected or compensated for other known effects. Nor140 has the ability to make corrections related to

- Use of windscreen
- Measurement of random incidence sound or diffuse sound fields
- Measurement of low levels (Option 18)

## Use of windscreen

A microphone windscreen is a useful device for reducing the noise created around the microphone in windy conditions. The windscreen is also useful for protecting the microphone from mechanical impacts and from dust. However, the application of a windscreen will slightly modify the frequency response of the instrument. To correct for this effect and retain the specification the windscreen correction has to be switched on while the windscreen is mounted.

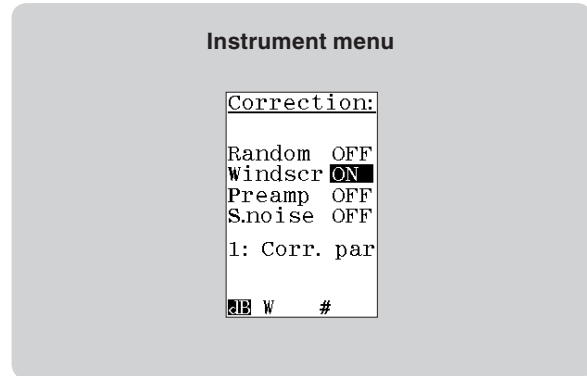

The windscreen correction is adapted to windscreen Nor1451. The nominal correction for the windscreen correction network is shown in section for specifications. Press **SETUP > 1** (Instr.) **> 4** (Input) **> 2** (Correct.) to gain access to the Corrections menu. Please note that you only get access to this menu if the input type is set to **STANDRAD**. Navigate in the menu as usual and activate the correction parameter Windscr by means of the **INC** and **DEC** keys. Do the similar operation to deactivate.

When the windscreen correction is applied, a “W” is displayed in the lower line of the display.



## Preamplifier correction

When the microphone is mounted on the preamplifier, a very small fraction of the signal is “lost” in the electronic parts. To compensate for this a small correction, usually 0.4 to 0.8 dB, can be adjusted for. The sensitivity that appears on the calibration menu may then correspond to the sensitivity that you get when the microphone is calibrated in a calibration laboratory.

The preamplifier correction is factory set to a correct level. A typical value is 0,4 to 0,8 dB. To alter this setting press **SETUP > 1 (Instr.) > 4 (Input) > 2 (Correct.) > 1 (Corr.par) > 1 (PreAmpAt)**.

## Random incidence and diffuse sound fields

The instrument is normally equipped with a microphone with flat free-field response and satisfies the class 1 requirements in IEC 61672-1 to free-field response. By selecting the random response correction network included, the instrument will satisfy the class 1 requirements in IEC 61672-1 to random response as well as ANSI S1.4-1997 Type 1. (Not included in the versions for the German speaking markets). The nominal correction for the random incidence correction network is shown in section for specifications.

Press **SETUP > 1 (Instr.) > 4 (Input) > 2 (Correct.)** to gain access to the Corrections menu. Navigate in the menu as usual and activate the correction parameter Random by means of the **INC** and **DEC** keys. Do the similar operation to deactivate. When the random incidence correction is applied, a “**R**” is displayed in the lower line of the display.

## Measurement of low sound levels

When measuring very low levels, the indicated level may be influenced by the self-noise of the instrument. If you measure an A-weighted level of 25 dB, which is about 10 dB above the typical self-noise of 15 dB, the contribution from the self-noise will make the reading to be 25,4 dB or 0,4 dB too high. Option 18 allows the A-weighted and C-weighted (Z-weighted) levels to be corrected before they are displayed.

The correction is done by subtraction of the energy related to the self-noise. The figure below shows the linearity error as a function of the difference between the true sound level and the self-noise level. The upper part shows the error without compensation, and the lower shows the error with ideal compensation and for a compensation where the estimated self-noise is +1 dB and -1 dB from the real self-noise level.

The correction is based on the following equation:

$$L_c = 10 \log \left\{ 10^{\frac{L_m}{10}} - 10^{\frac{L_{noise}}{10}} \right\}$$

where

*L<sub>m</sub>* is the measured level (signal plus self-noise),

*L<sub>noise</sub>* is the self-noise level and

*L<sub>c</sub>* is the corrected level shown on the display.

Press **SETUP > 1 (Instr.) > 4 (Input) > 2 (Correct.)** to gain access to the Corrections menu. Move the field cursor to “S.noise” (self-noise) and toggle the value to “ON” by using the **INC** or **DEC** keys. Press **1** for correction parameters. Enter the values in dB for the self-noise for the different weightings: A, C and Z. Use the arrow keys to move the field-cursor between the fields.

Press **ENTER** after entering a numeric value and for leaving the menu.

**Linearity error without and with correction**

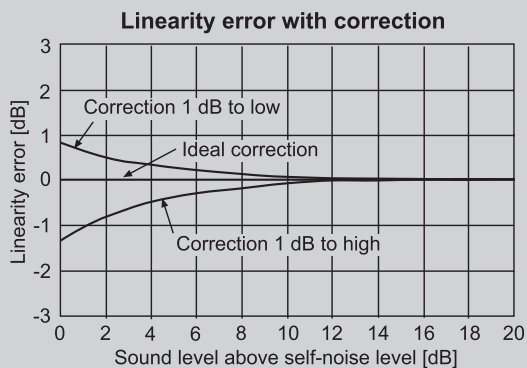
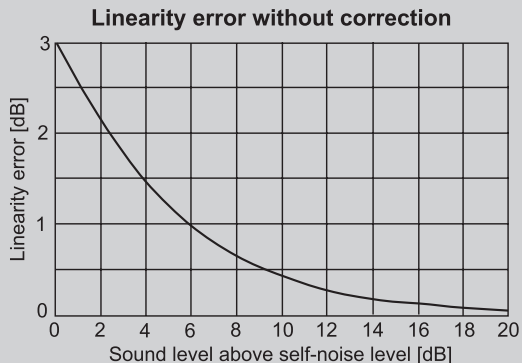

When the self-noise correction is active a “S” is displayed in the lower line of the display.

**Measuring the self-noise**

The self-noise of a sound level meter is the indication on the meter when the instrument is placed in a quiet place where the actual sound pressure level is considerably (20 dB) less than the self-noise.

The self-noise should be measured with the actual microphone after proper calibration of the instrument. Note that a dummy-microphone, often used for checking the self-noise of an instrument, cannot be used. Use of a dummy-microphone will only indicate the electrical noise of the system, and not the noise related to the acoustic impedance of the microphone.

If you don't have access to a required quiet place, the instrument may be placed inside a closed vessel placed on a place with low vibration. We recommend using some acoustic damping material in the vessel. If you have the Trigger option (Option 16), we recommend to use the clock-trigger for starting a measurement after the vessel is closed.

**Measurement of high sound levels**

When the option 18 for extended measurement range is installed and the microphone normally delivered with the instrument, Nor1225, is used, the measurement range may be shifted 10 dB upwards. This is achieved by lowering the polarisation voltage for the microphone



If you don't know the self-noise of your particular instrument within  $\pm 2$  dB, don't use the optional correction for self-noise.

from 200 V to about 70 V. The microphone sensitivity will then be reduced by 10 dB and the instrument will be able to measure peak signals up to 150 dB.

The change in the polarisation voltage will lead to a small change in the frequency response for the microphone. This change is automatically compensated when the extended measurement range is selected. Since this correction is adapted to the microphone Nor1225, the extended measurement feature should not be used with other types of microphones.

To activate or de-activate the extended measurement range, press **SETUP > 1 > 4 > 1**. This submenu is only possible to access if STANDARD input is selected in **SETUP 1 > 4**. An "H" is displayed in the lower part of the display when extended range is selected.

Normally a recalibration of the instrument is not needed. However, it is good practice to check the sensitivity of the instrument. This can easily be done by applying the usual sound calibrator. The sound level meter shall indicate the usual level as stated for the calibrator also when the extended measurement range is selected.



### Marks on the lower line of the display

Marks for the applied corrections are found on the lower line of the display:

- dB** The signal strength is indicated as a level in decibel. The reference level is normally 20  $\mu$ Pa for sound pressure levels.
- EU** Engineering unit: The signal strength is indicated in a generic linear unit. The actual unit could be voltage referring to the voltage on the input terminal or ms-2 if an accelerometer is connected to the input.
- #** Numerical keyboard. The number printed on the keys are entered if you press one of the keys on the keyboard
- E** A numeric value has been entered. The instrument expects that you press **ENTER** to confirm the number.
- N/H** Indicates **N**ormal or **H**igh measurement range. (Polarization voltage dependant.)
- ?** A key is pressed that the instrument does not understand.

Additionally there are marks indicating the applied corrections found on the lower line of the display:

- R** Random incidence correction ON
- W** Wind screen correction ON
- G** Preamplifier correction ON
- S** Self-noise correction ON
- E** Polarization voltage off - Electret microphone

# Reverberation time measurements

The optional extension 9 for the Nor140 permits measurements of the reverberation time. The reverberation time is simultaneously measured in every frequency band.

Reverberation time is not something you measure directly, it is a result calculated from a measured response.

The calculation algorithms used comply with the requirements set by ISO 354: 2003 Acoustics – Measurement of sound absorption in a reverberation room and ISO 3382:1997 Acoustics – Measurement of the reverberation time of rooms with reference to other acoustical parameters. Typical applications include the measurement of reverberation time as required in the International standards for building acoustics given by the ISO 140-series.

The instrument calculates the reverberation in the range 63 Hz to 8 kHz when 1/1-octave bandwidth is selected, and in the range 50 Hz to 10 kHz for 1/3-octaves.

You can use the Mode 2 button sequence to verify that the reverberation option (Option 9) is installed in your instrument.

## What is reverberation time?

Assume that you switch on a sound source in a room equipped with a microphone system. You will note that the sound level will not reach a steady level immediately. The reason why is that the sound will consist of the direct sound radiating from the source in combination with reflected sound and these reflections take time before they reach the microphone.

If you now switch off the sound source, the sound will take some time to decay. For most rooms without significant echoes, the level will decay linearly with the time until the noise floor is reached. The time it takes for the sound pressure to decay by 60 dB is called the reverberation time. However, the calculation in Nor140 is based on the decay in the range 5 dB to 25 dB below the stationary level and extrapolated to obtain the 60 dB range value. Reverberation times measured this way are often denoted T20. In a similar way T30 is based on the decay in the range 5 dB to 35 dB below the stationary level.

Two methods of measuring decay curves are described in the referred International Standards: The interrupted noise method and the integrated impulse response method. Nor140 can apply both the integrated impulse response method and the interrupted noise method if option 10, internal noise generator, is

additionally installed. The integrated impulse response method is often called Schroeder method after Dr. Manfred Schroeder who disclosed the theoretical relations between this and the interrupted noise method. The reverberation time is extracted from the decay by the use of a least mean square fit algorithm.

A third way of reverberation time measurements is also available. This measurement option enables a swept sine excitation signal. Sophisticated signal analyses of the measured response gives robust and accurate results.

The decay curve measured with the interrupted noise method is the result of a stochastic process, and averaging several decay curves or reverberation times measured at one microphone/loudspeaker position is mandatory in order to obtain a representative value. The integrated impulse response of a room is a deterministic function and not prone to statistical deviations, so no averaging is necessary. However, for many applications you still need spatial averaging, as described in the measurement standards

## Calculating the reverberation time

### Measurement with noise excitation

Measuring the reverberation time by using interrupted noise is often referred to as the classical method. The noise source is switched on for a time sufficient to obtain a steady level. The source is thereafter switched off, and the decay of the sound in the room is observed. Without loss of generality, the time for switching the noise off may be set to  $t = 0$ .

A plot of the sound pressure level versus time will in general contain information on the obtained stationary sound pressure level in the room  $L_0$  as well as the

reverberation time. A typical level versus time diagram is shown on the adjacent figure. The background level is indicated as  $L_N$

Information about the decay will be given for  $t > 0$ . The decay may be further processed to obtain the reverberation time.

The classical methods for the measurement of airborne sound in rooms, defined in the ISO 140- and the ISO 3382-series of International Standards specify a stochastic signal for the excitation. Although the room in most cases may be described as a deterministic system, statistical spread from the random excitation will lead to a certain stochastic variation in the result, which may be characterised by a standard deviation.

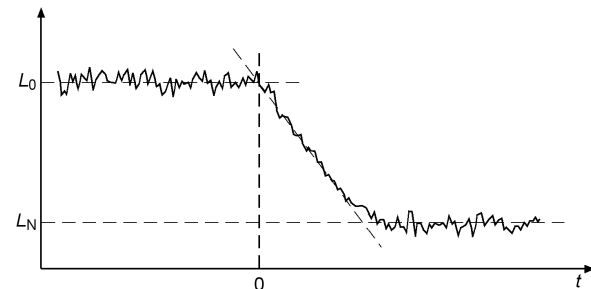

Reverberation decay

Therefore, averaging of more measurements is normally needed to obtain results close to the stochastically expected values. Such averaging may for the classical method be combined with the spatial averaging needed to obtain a mean value for the room.

### Measurement with impulse excitation

M.R. Schroeder [1] has shown that the expected decay in one particular observation point may be obtained without averaging by processing the impulse response between the excitation signal (loudspeaker) and the

observation point (microphone) directly. This holds as long as the system is linear and time-invariant.

The measured response in the classical method based on noise excitation may in theory be described as a convolution between the excitation signal and the impulse response of the room. However, in the classical method with noise excitation the response is recorded directly and information about the impulse response is normally not known.

According to the Schroeder methods, the results may be obtained from processing of the impulse response itself.

When a room has been excited by stationary white noise for a time sufficient to obtain stationary conditions and the noise is thereafter switched off at the time  $t = 0$ , the expected level at any time  $t \geq 0$  will be [1]:

$$L(t) = 10 \times \lg \left[ \frac{W_0}{C_{ref}} \int_t^\infty h^2(\tau) d\tau \right] \text{ dB}$$

where

$W_0$  is a constant specifying the signal power per unit bandwidth of the excitation signal;

$h(t)$  is the impulse response; and

$C_{ref}$  is an arbitrary selected reference value for the level calculation.

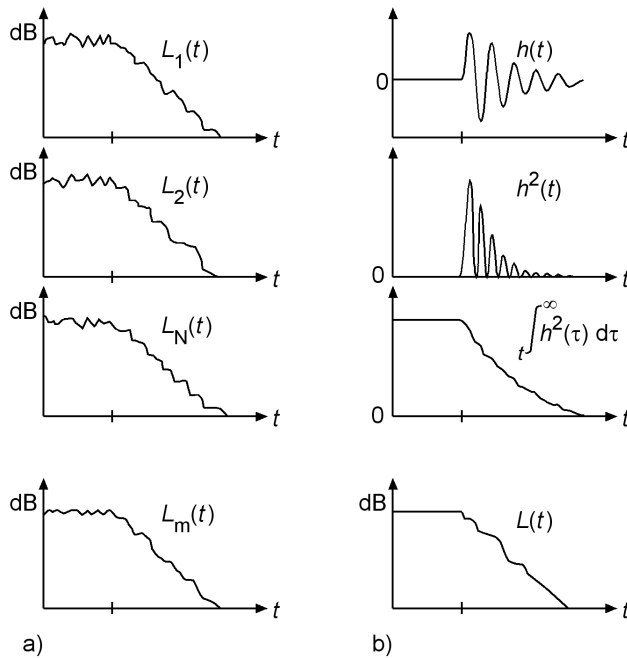

Calculation of reverberation time: a) based on the "classical" interrupted noise method and b) based on impulse excitation. For the classical method the mean decay may be obtained by averaging more decays. By the use of the impulse method the expected decay is calculated from the impulse response for the room.

The decay corresponds to the expected decay based on the classical method, which conventionally is approximated by a straight line.

Due to the fact that the running time,  $t$ , is the lower start point for the integration, the operation of the formula in the equation may be described as backward integration. In an alternative form of the formula, the integral starts at  $\infty$  and runs backward to the actual time. Historically, this was achieved using analogue technology by playing a tape with the recorded response in the reversed direction.

The formula does not consider the extraneous noise normally accompanying a measurement.

When a fractional-octave-band filter is a part of the measured system, the formula will describe the expected decay according to the classical method for the applied filter band.

The difference between the classical and the Schroeder method may be illustrated by the figure on the adjacent side. For the classical method, a), the averaged decay is obtained by averaging a number

of measurements. For the Schroeder method, b), the expected decay is obtained by processing of the impulse response  $h(t)$ .

### Measurement with swept sine excitation

New technology and the use of digital signal processors make also other types of sophisticated analyses possible. The Swept-Sine technique is excellent for reverberation time measurements in high background noise and of short reverberation times.

For the technically interested reader: The sine sweep signal covers the frequency range from 42.2 Hz to 23.7 kHz. The sweep is logarithmic and it is performed in 1.5 seconds. Data acquisition takes 2.73 seconds. The signal sampling rate is 48 kHz. The FFT of the received signal is divided with the FFT of the excitation signal and filtered (using a window function) to remove unwanted distortions. Then this signal is run through an inverse FFT process to get a wideband impulse response which finally is sent through the actual octave filter set so the reverberation time can be calculated.

This calculation process is quite complex and it takes some time to perform it.

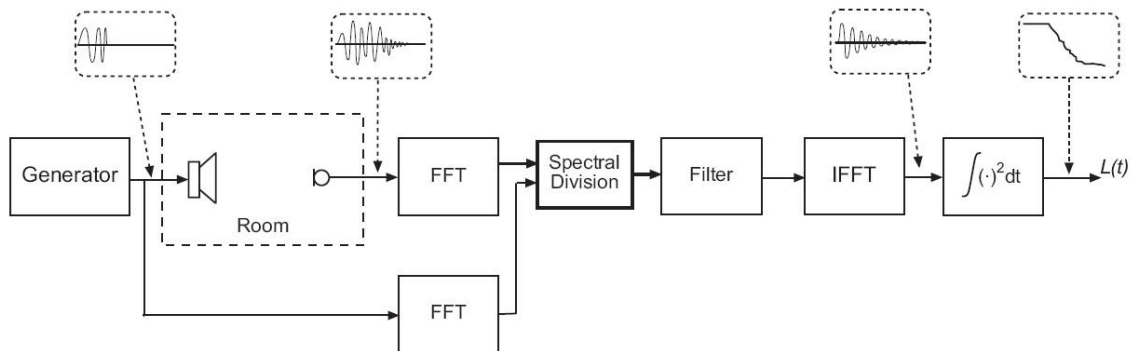

### Implementation in Nor140

The instrument can be set to measure reverberation times with various maximum lengths. See section below. The following description is valid for the maximum length default selection of 4 seconds.

**Impulse excitation.** When the instrument is set up for measurements of reverberation time based on impulse excitation, the instrument starts logging the level in each octave or 1/3-octave band with a time resolution of 5 ms. Each sample will represent the Leq-value for each 5 ms. period (200 level values per second). The sequence of these samples are stored during the measurement and processed as soon as the measurement is ended. The backward integration is started from the cross point between the decay and the background noise. The back-integrated curve can now be obtained with a time resolution of 5 ms for each filter band. Samples between 5 dB and 25 dB below the maximum are used for the calculation of T20 by application of regression. In a similar way values between 5 dB and 35 dB are used for calculating the T30 value. A least-square-fit regression method is used for fitting a linear decay curve which is used for the reverberation time calculation. The instruments automatically compare the lowest levels for the calculation with the estimated background level and gives warnings if the distance is not sufficient.

**Noise excitation.** When the reverberation time is measured with interrupted noise from the internal noise generator, the level is logged with a time resolution of 5 ms from the time the noise is switched off. A least-square-fit regression method is used for fitting a linear decay which is used for the reverberation time calculation. Levels between -5 dB and -25 dB relative to the level before the noise was switched off are used for calculating T20. In a similar way levels between -5 dB and -35 dB are used for T30 calculation.

**Swept Sine excitation.** When the Swept Sine method is used, the wide band impulse response is calculated. This signal is fed through the filter section as if it was a measured response. The filtered signal is sampled with a time resolution of 1 ms. This gives a higher resolution and the possibility to measure shorter reverberation times. The reverberation times are calculated in the same way as for Impulse excitation.

Ref.[1] Schroeder, M.R., "New Method of Measuring Reverberation Time". J. Acoust. Soc. Am., vol. 37 (1965) pp. 409 – 412.

The Reverberation Menu

SETUP:  
1: Instrument menu  
2: Reverberation  
3: Noise gen.  
4: Frequency mode  
5: Recording

N #

The Excitation Signal Menu

Noise ctrl:  
Gen: OFF  
Sync: OFF  
Type: WHITE  
Gain: -20 dB

G



## Excitation signals

**Impulse excitation.** Excitation for the integrated impulse response method may be any impulsive, broad-band source with suitable low directivity. This may be a pistol shot, an exploding paper bag or an exploding balloon capable of creating enough sound energy in the frequency range you need.

An advantage of using impulse excitation is that you don't have to carry heavy loudspeaker/amplifier combinations with you. In addition you will be able to rely on battery operation alone with no need for mains voltage. By using noise excitation through a loudspeaker you will more easily verify proper levels and directional characteristics of the source.

**Noise excitation.** When the interrupted noise method is applied you have to use the signal from the optional internal noise generator. (Option 10 - available on the multi function socket on the left hand side of the instrument.) Feed the signal to a suitable power amplifier and loudspeaker. The power amplifier Nor280 and the dodecahedron loudspeakers Nor250 and Nor270 may be applied. By using noise signals through a loudspeaker it may be easier to obtain a sufficiently loud sound level and to excite all the different reverberation modes of the room.

**Swept Sine excitation.** The swept sine method also make use of the internal noise generator, power amplifier and generator. The sine sweep signal covers the frequency range from 42.2 Hz to 23.7 kHz. The sweep is logarithmic and it is performed in 1.5 seconds. Data acquisition takes 2.73 seconds. The signal sampling rate is 48 kHz.

## Minimum reverberation time possible

The frequency analysis in the form of 1/3- and 1/1- octave filters sets a lower boundary for the reverberation times that can be measured. All frequency selective devices such as a filter will have a response shortly after removal of an input signal. This will create a virtual reverberation time and the instrument can not measure below this limit. If the measured reverberation time is below the lower limit for reliability, the value will be marked by an adjacent question mark. The table below shows the virtual reverberation times and the corresponding lower limits for a reliable measurement as a function of frequency and bandwidth. The values of these virtual reverberation times are increased slightly to cover for strong fluctuations in the decay curves.

## Maximum reverberation times

The longest reverberation time it is possible to measure is a function of the sampling speed of the reverberation curve. The default selection gives a maximum reverberation time of 4 seconds with a sampling rate of 5 ms. Alternatively you can select 8, 16 or 32 seconds. The sampling interval will be increased accordingly from 5 ms to 40 ms. Please note that this will not necessarily have a negative impact on the resolution and accuracy of the reverberation time calculation where the least square fit method is used.

<b>Minimum reverberation times</b>				
Frequency	RTmin [s]	RTmax [s]	Lower limit 1/3-oct	Lower limit 1/1-oct
50 Hz	0.20	15	0,60	
63 Hz	0.14	15	0,48	0,24
80 Hz	0.14	15	0,38	
100 Hz	0.10	15	0,30	
125 Hz	0.09	15	0,24	0,12
160 Hz	0.08	15	0,19	
200 Hz	0.07	15	0,15	
250 Hz	0.06	15	0,12	0,06
315 Hz	0.05	15	0,10	
400 Hz	0.04	15	0,08	
500 Hz	0	15	0,06	0,03
630 Hz	0	15	0,05	
800 Hz	0	15	0,04	
1 kHz	0	15	0,03	0,02
1.25 kHz	0	15	0,02	
1.6 kHz	0	15	0,02	
2 kHz	0	15	0,02	0,01
2.5 kHz	0	15	0,01	
3.15 kHz	0	15	0,01	
4 kHz	0	15	0,01	0,01
5 kHz	0	15	0,01	
6.3 kHz	--		0,01	
8 kHz	--	--	0,01	0,01
10 kHz	--		0,01	

The level above which trigger will take place (provided that a level transition takes place) is shown as a horizontal dotted line. This line is always located 30 dB below the display top scale. To “move” the line up and down (what you do is to change the display top scale) use the **INC** and **DEC** keys. The position of the graph cursor (the frequency cursor) determines the frequency band to be used as trigger band

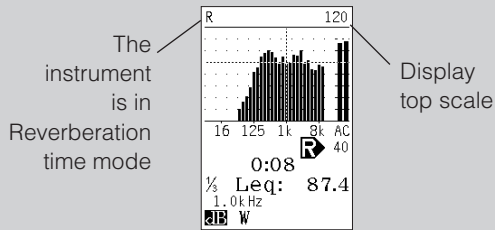

## Measuring according to the integrated impulse response method

The instrument has to be set in a special mode of operation in order to measure the reverberation time. Press **MODE > 2** for Reverberation. Select the frequency mode “On” and the appropriate filter bandwidth – 1/1- or 1/3-octave. (See the chapter Frequency analysis for details.) Press the **SETUP** button to change the set up for the reverberation mode.

### Reverberation Menu

```

SETUP:
1: Instrument menu
2: Reverberation
3: Noise gen.
4: Frequency mode
5: Recording

N #
    
```

Make sure the excitation type is set to Impulse. Press **SETUP > 2** and move the cursor field to excitation type (Ex.type) and select “IMP” by the use of the **INC** or the **DEC** key.

### Reverberation Setup

```

Rev. setup:
Max RT: 4s
Ex.type: IMP

Decay : OFF
Audio : OFF

ImpResp:OFF
N
    
```

There are two storing options for reverberation time measurements. The result table will always be stored, of course, but in this menu you may also turn on or off the storage of the decay curve and the audio recording of the impulse. Please note that both of these alternatives takes a lot of the available memory so do not use it unless it is needed for further investigations and analysis. (You can use **SETUP > 5** to activate the menu where the quality of the audio recording is set up.) Set “Decay”, “Audio” and “ImpResp” to “OFF” for the simplest and most effective reverberation time measurements. Press **ENTER** twice to leave the menu and enter reverberation ready mode.

### Reverberation Ready

Reverberation Ready

The letter **R** in the upper left corner of the display indicates that the instrument now is in reverberation time mode. By default, the cursor is located on the 1 kHz frequency band. The cursor position determines the frequency band used to trigger the measurement.

If 1 kHz is not suitable as trigger band – which may well be the case – use the cursor keys to move the cursor in the usual manner.

You will note a dotted horizontal line located 30 dB below the displayed top scale. Remember that the displayed top scale is purely a display feature and not related to the measurement range setting. This line represents the trigger level threshold for the impulse decay capture.

Use the **INC** or **DEC** key to change the displayed full scale and thereby the trigger level threshold in 10 dB steps, if applicable.

Press the **START** key. The instruments start logging the level and waits for the trigger condition to be fulfilled. While waiting, a **W** (waiting) is displayed. Once the instrument detects a level above the threshold in the frequency band you have specified, the capture of the impulse and its decay will begin. An **R** will appear in the display when the measurement is running.

**You should make the impulse excitation as soon as the W mark is displayed.**

Once you have pressed the **START** key the trigger setting cannot be changed, even if the measurement is not yet running. To be able to change these settings you must terminate the ongoing measurement. To terminate an ongoing measurement you have to press **STOP** or **PAUSE/CONT**. In both cases the instrument will return to ready condition. If a measurement has been made and the result table is displayed, press **EXIT** twice to enter this condition.

During the measurement, the instrument will show the remaining measurement time. The total measure-

ment time is 5 seconds for 4 seconds maximum reverberation time selection, and 10, 20 and 40 seconds for 8, 16 and 32 seconds maximum times respectively. If you are measuring very short reverberation times you may terminate the measurement as soon as the background noise level has been reached by pressing **STOP**.

The calculation of the reverberation times are automatically performed as soon as the measurement is terminated and the values are shown in a table.

The table shows the calculated reverberation time for each frequency band and for the spectral weighting networks (A- and C- or Z-weighting). If the reverberation time measured is too short compared to the values in the table for minimum reverberation times, a question mark will be shown to the right of the value. If the signal-to-noise ratio is insufficient for calculating the reverberation time, the sign “-.-” will be displayed instead of a value. An overload is marked by \*.

Press **FUNC** for displaying T20 or T30 as appropriate.

**Reverberation Table**

R	
½-oct	T20
400Hz	0.43
500Hz	0.44
630Hz	0.54
800Hz	0.46
<b>1.0kHz</b>	<b>0.52</b>
1.25kHz	0.48
1.6kHz	0.58
2.0kHz	0.56
2.5kHz	0.53
N	

After the measurement you may inspect the level profile of the measured signal by pressing the key **Σ↔Δ**. Note that the logging of the profile starts when you press the start button, the impulse may therefore be located outside the displayed time limit. Move the cursor to scroll along the time axes. You may compress the

display by pressing the key **▶**. The factor for compression is displayed as C=2 etc. In a similar way the graph may be expanded by pressing the key **◀**. C=-2 means two time expansion.

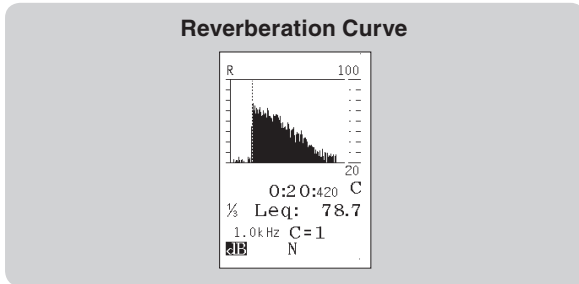

To store the values of reverberation time, press **STORE** and the result are stored and automatically assigned a file number displayed at the top of the display. The values may later be retrieved by pressing **RECALL**.

## Measuring according to interrupted noise method

The instrument has to be set in a special mode of operation in order to measure the reverberation time and this method requires option 10 - Noise generator. Press **MODE > 2** for Reverberation.

In the set up menu you will find the mode specific set up features.

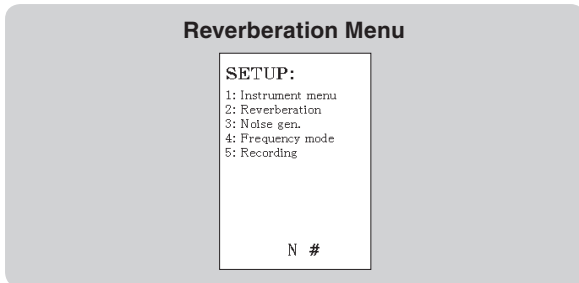

Use **SETUP > 4** to turn frequency mode “On” and set the appropriate filter bandwidth – 1/1- or 1/3-octave. (See the chapter Frequency analysis for details).

Then set up the noise generator.

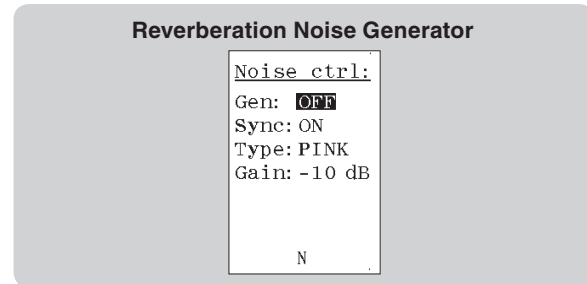

Press **SETUP > 3** and move the cursor field and use **INC** or **DEC** key to set:

- Generator (Gen:) to “OFF”
- Synchronisation (Sync:) to “ON”
- Select the wanted noise type
- Set the gain to select the excitation level. 0 dB is the highest and -50 dB is the lowest level. NB: Start with a low level if you are unsure about the gain of your amplifier.
- Select the wanted noise type
- Set the gain to select the excitation level. 0 dB is the highest and -50 dB is the lowest level. NB: Start with a low level if you are unsure about the gain of your amplifier.

**Reverberation Table**

R	
½-oct	T20
400Hz	0.43
500Hz	0.44
630Hz	0.54
800Hz	0.46
1.0k Hz	0.52
1.25k Hz	0.48
1.6k Hz	0.58
2.0k Hz	0.56
2.5k Hz	0.53
N	

Make sure the excitation type is set to Noise. Press **SETUP > 2** and move the cursor filed to excitation type (Ex.type) and select “NOS” by the use of the **INC** or the **DEC** key.

Set the time duration for the excitation (Ex.time:) . The time is given in seconds. The value should be at least equal to half the reverberation time to be measured.

In this menu there are two storing options for reverberation time measurements. The result table will always be stored, of course, but in this menu you may also turn on or off the storage of the decay curve and the audio recording of the impulse. Please note that both of these alternatives takes a lot of the available memory so do not use it unless it is needed for further investigations and analysis. Set “Decay”, “Audio” and “ImpResp” to “OFF” for the simplest and most effective reverberation time measurements. Press **ENTER** twice to leave the menu and enter reverberation ready mode.

Press **ENTER** twice to leave the menu and enter reverberation ready mode.

The selected topscale has no influence on the measurement in this mode of operation.

Press the **START** key. The instruments switch on the noise for the selected excitation time and present the **W**-mark. The logging of the level starts when the noise is switched off and the run indicator **R** is displayed.

The instrument will measure for a number of seconds dependant on the maximum expected reverberation time (from 5 to 40 seconds) and count down to 0 to indicate how much is left of the measurement. The acquired results are then presented as a table. If you are measuring very short reverberation times you may terminate the measurement as soon as the background noise level has been reached by pressing **STOP**.

The calculation of the reverberation times are automatically performed as soon as the measurement is terminated and the values are shown in a table. The table shows the calculated reverberation time for each frequency band and for the spectral weighting networks (A- and C- or Z-weighting). If the reverberation time measured is too short compared to the values in the table for minimum reverberation times, a question mark will be shown to the right of the value. If the signal-to-noise ratio is insufficient for calculating the reverberation time, the sign “-.-” will be displayed instead of a value.

Press **FUNC** for displaying T20 or T30 as appropriate.

After the measurement you may inspect the level profile of the measured signal by pressing the key  $\Sigma \leftrightarrow \Delta$ . Note that the logging of the profile starts when you press the start button, the impulse may therefore be located outside the displayed time limit. Move the cursor to scroll along the time axes. You may compress the display by pressing the key  $\blacktriangleright$ . The factor for compression is displayed as C=2 etc. In a similar way the graph may be expanded by pressing the key  $\blacktriangleleft$ .

To store the values of reverberation time, press **STORE** and the result are stored and automatically assigned a file number displayed at the top of the display. The values may later be retrieved by pressing **RECALL**. However, no profile will be shown from recalled files since the profile is not stored with the result.

### Measuring according to the Swept Sine method

The instrument has to be set in a special mode of operation in order to measure the reverberation time. Press **MODE > 2** for Reverberation. Select the frequency mode "On" and the appropriate filter bandwidth to 1/1- or 1/3-octave. (See the chapter Frequency analysis for details.)

Press the **SETUP** button to change the set up for the reverberation mode.

Make sure the instrument is set to Swept Sine Impulse Response method.

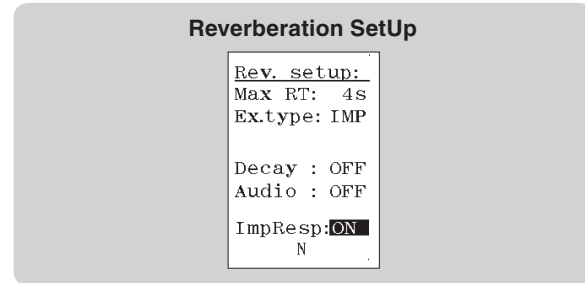

Press **SETUP > 2** and move the cursor filed to excitation type (Ex.type) and select "IMP" by the use of the **INC** or the **DEC** key. Then select the swept sine method ("ImpResp: ON") in a similar way, as shown in the picture.

There are two storing options for reverberation time measurements. The result table will always be stored, of course, but in this menu you may also turn on or off the storage of the decay curve and the audio recording of the impulse. Please note that both of these alternatives takes a lot of the available memory so do not use it unless it is needed for further investigations and analysis. Set both "Decay" and "Audio" to "OFF" to save memory. Press **ENTER** twice to leave the menu and enter reverberation ready mode.

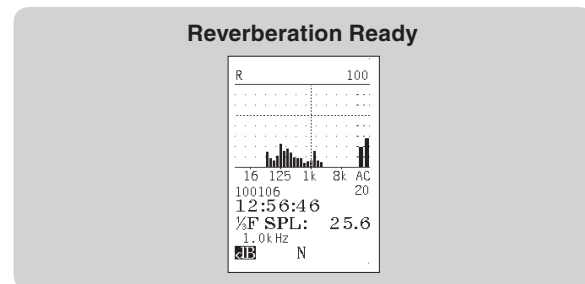

The letter **R** in the upper left corner of the display indicates that the instrument now is in reverberation time mode.

Press the **START** key. The instruments start sending out the swept sine sequence and at the same time start the logging the response. A special picture appears on the screen.

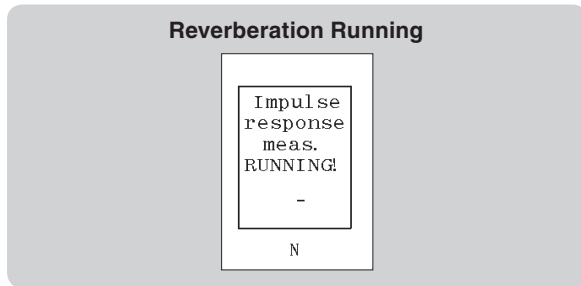

Once you have pressed the **START** key then you have to wait for this sequence to finish and it takes about one minute.

The calculation of the reverberation times is automatically performed and the result values are shown in a table. The table shows the calculated reverberation time for each frequency band and for the spectral weighting networks (A- and C- or Z-weighting). If the signal-to-noise ratio is insufficient for calculating the reverberation time, the sign “-.-” will be displayed instead of a value. An overload is marked by “\*”.

Press **FUNC** for displaying T20 or T30 as appropriate.

**Reverberation Table**

R	
X-oct	T20
400Hz	0.43
500Hz	0.44
630Hz	0.54
800Hz	0.46
1.0k Hz	0.52
1.25k Hz	0.48
1.6k Hz	0.58
2.0k Hz	0.56
2.5k Hz	0.53
N	

To store the values of reverberation time, press **STORE** and the result are stored and automatically assigned a file number displayed at the top of the display. The values may later be retrieved by pressing **RECALL**.



# Sound Power

## About sound power measurements

Sound power may be calculated from sound pressure levels using the Nor140 equipped with option 15. The method is described in ISO 3746 acoustics – determination of sound power levels of noise sources – survey method and requires measurements of the A-weighted sound pressure level at four or more positions located on a hypothetical measurement surface of an area  $S$  which envelopes the source.

To facilitate the location of the microphone positions on the measurement surface a hypothetical reference box shall be defined. When defining the dimensions of this box, elements protruding from the source which are not significant radiators of sound energy may be disregarded.

The measurement surface on which the microphone positions lie envelopes the source as well as the reference box.

The location of the source under test, the measurement surface and the microphone positions are defined by a coordinate system with the horizontal axes  $x$  and  $y$  in the ground plane parallel to the length and width of the reference box. The characteristic dimension  $d_0$  is shown in the Fig. on the next page.

One of the following two shapes shall be used for the measurement surface:

- a** a rectangular parallelepiped box whose sides are parallel to those of the reference box. In this case the measurement distance  $d$  is the distance between the measurement surface and the reference box.
- b** a hemispherical surface or partial hemispherical surface of radius  $r$ ;

For measurement objects located in rooms or spaces under unfavourable acoustical conditions (e.g. many reflecting objects and high levels of background noise), the selection of a small measurement distance is appropriate and usually dictates the selection of a *parallelepiped* measurement surface. For other test objects mounted and/or to be measured in large open areas under satisfactory acoustical conditions, a larger measurement distance is usually selected and in this case the *hemispherical* measurement surface is preferred.

For measurements on a series of similar sources (e.g. machines of the same type or a given family of equipment), the use of the same shape of measurement surface is preferred.

A test report shall always contain information on the reference box, the size and shape of the measurement surface, as well as the measurement distance  $d$  or the radius of the hemisphere  $r$ .

The figures shows the characteristic dimension  $d_0$  for the different locations of the source under test.

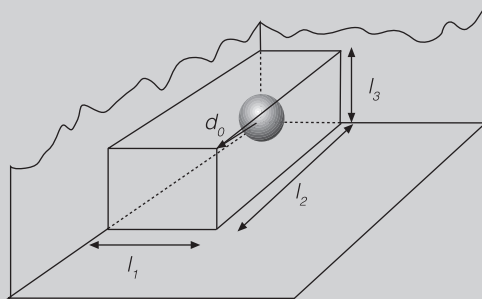
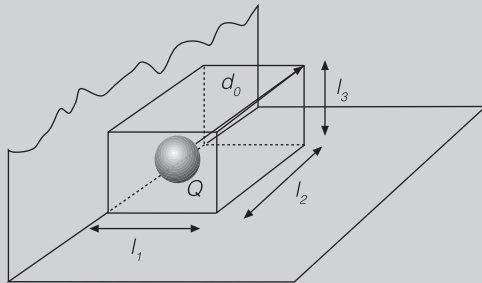
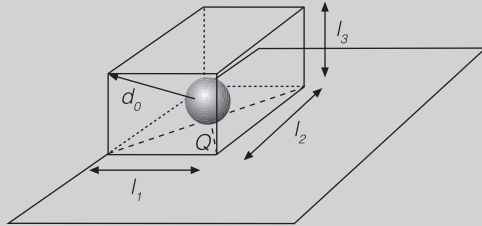

Reference box on three reflecting planes

## Rectangular parallelepiped

For the rectangular parallelepiped reference box there are three possible configurations as shown in the Fig to the left.

The characteristic dimension  $d_0$  can be calculated from the following formulae:

**Reference box on one reflecting plane:**

$$d_0 = \sqrt{\left(\frac{l_1}{2}\right)^2 + \left(\frac{l_2}{2}\right)^2 + l_3^2}$$

**Reference box on two reflecting planes:**

$$d_0 = \sqrt{\left(\frac{l_1}{2}\right)^2 + l_2^2 + l_3^2}$$

**Reference box on three reflecting planes:**

$$d_0 = \sqrt{l_1^2 + l_2^2 + l_3^2}$$

## Hemispherical measurement surface

The hemisphere shall be centred in the middle of the box consisting of the reference box and its images in the adjoining reflecting planes, point  $Q$  in the Figs. overleaf. The radius  $r$  of the hemispherical measurement surface shall be equal to or greater than twice the characteristic source dimension  $d_0$  and not less than 1 metre.

The radius of the hemisphere should be one of the following values (in metres): 1, 2, 4, 6, 8, 10, 12, 14 or 16. Some of these radii may be too large to meet the environmental requirements given in ISO3746. If so, such large values shall not be used.

The environmental requirements state that the reflecting plane must not be of such a material or in such a condition that it radiates any appreciable sound energy due to vibration. If the measurements are made outdoors over grass- or snow-covered ground, the measurement distance shall not exceed 1 metre. The general requirement is that the sound absorption coefficient of the reflecting plane shall be less than 0.1 over the frequency range of interest. Also no reflecting objects that are not part of the source under test shall be located inside the measurement surface.

### Hemispherical microphone positions

If there is only one reflecting plane, the microphone positions lie on the hypothetical hemispherical surface of area  $S = 2\pi r^2$ , enveloping the source and terminating on the reflecting plane. If the source under test is in front of a wall,  $S = \pi r^2$  and if it is in a corner,  $S = 0.5\pi r^2$ .

Microphone positions on a hemisphere - key microphone positions

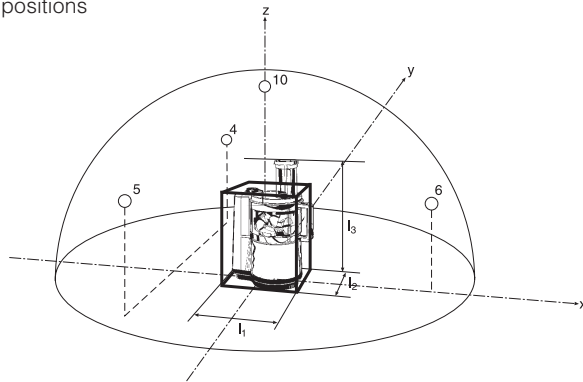

The Fig. below left shows the location of four key microphone positions, each associated with equal areas on the surface of the hemisphere of radius  $r$ .

If a source is installed adjacent to more than one reflecting plane, the Figs. shown on the next page are used to define a suitable measurement surface and the microphone positions.

### Additional microphone positions

Sound pressure level measurements are required at additional microphone positions on the hemispherical measurement surface if:

- a** the range of sound pressure level values measured at the key microphone positions (i.e. the difference in decibels between the highest and lowest sound pressure levels) exceeds twice the number of key measurement points, or
- b** the source radiates noise with a high directivity, or
- c** the noise from a large source is radiated only from a small portion of the source, e.g. the openings of an otherwise closed machine.

If condition **a** exist, additional microphone positions shall be used. For the microphone array on the hemisphere, an additional 4-point array is defined by rotating the original array through  $180^\circ$  about the  $z$ -axis. Note that the top point of the new array is coincident with the top point of the original array. The number of microphone positions is increased from 4 to 7.

Conditions **b** and **c** require more measurements in the region of high radiation.

Microphone Array on the Hemisphere

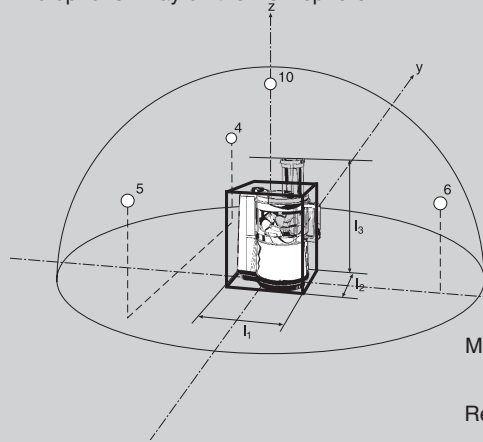

One reflecting plane

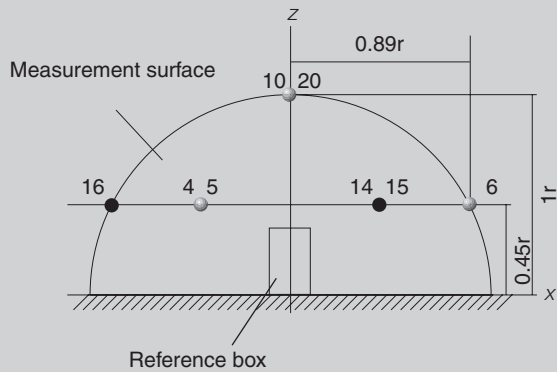
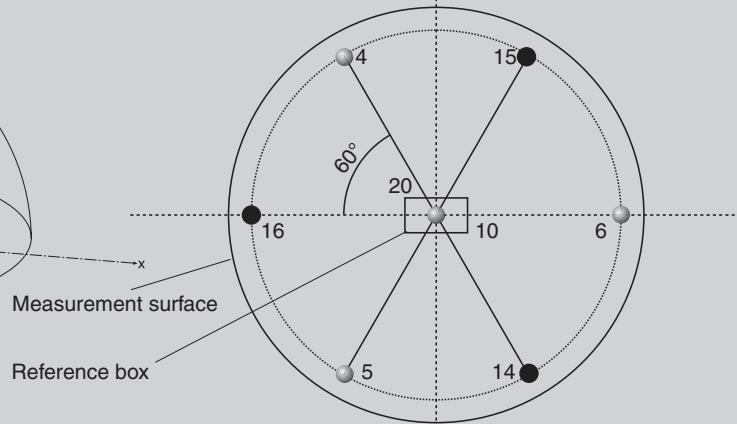

Two reflecting planes

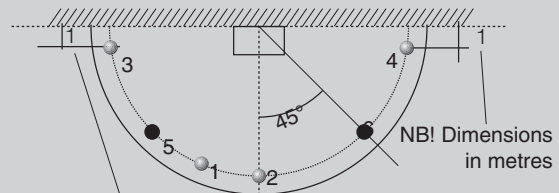

NB! Dimensions in metres

Three reflecting planes

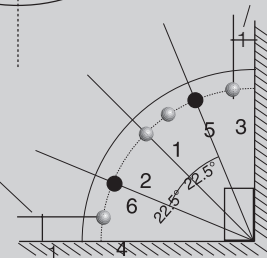

- Key microphone positions
- Additional microphone positions

Key microphone positions are numbered 4,5,6 and 10, additional microphone positions are numbered 14, 15, 16 and 20.

### Parallelepiped measurement surface

The measurement distance  $d$  is the perpendicular distance between the reference box and the measurement surface. The preferred value of  $d$  is 1 m and should be at least 0.15 m.

The value of  $d$  should be one of the following values (in metres): 0.15, 0.25, 0.5, 1, 2, 4 or 8. Measurement distances larger than 1 m may be selected for large sources. There are environmental requirements that should be satisfied for the value of  $d$  selected.

In brief, the environmental requirements state that the reflecting plane must not be of such a material or in such a condition that it radiates any appreciable sound energy due to vibration. If the measurements are made outdoors over grass- or snow-covered ground, the measurement distance shall not exceed 1 metre. The general requirement is that the sound absorption coefficient of the reflecting plane shall be less than 0.1 over the frequency range of interest. Also no reflecting objects that are not part of the source under test shall be located inside the measurement surface.

---

Microphone array on the parallelepiped - valid for larger machines.

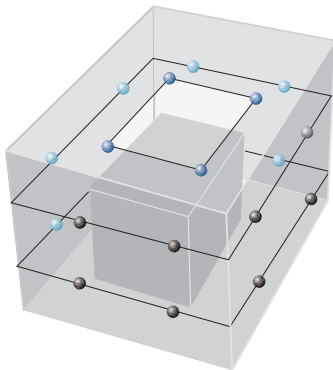

### Microphone positions

The microphone positions lie on the measurement surface, a hypothetical surface of area  $S$  enveloping the source whose sides are parallel to the sides of the reference box and spaced out a distance  $d$  (measurement distance) from the box.

The microphone positions on the parallelepiped measurement surface are shown on the following pages. The area  $S$  of the measurement surface according to the microphone position figures is given by the formula:

$$S = 4(ab + bc + ca)$$

where

$$a = 0.5l_1 + d, \quad b = 0.5l_2 + d \quad \text{and} \quad c = 0.5l_3 + d$$

and  $l_1$ ,  $l_2$  and  $l_3$  are the length, width and the height of the reference box.

If a source is installed adjacent to more than one reflecting plane, reference shall be made to the corresponding figures.

### Additional microphone positions

Sound pressure level measurements are required at additional microphone positions on the parallelepiped measurement surface if

- a** the range of sound pressure level values measured at the key microphone positions (i.e. the difference in decibels between the highest and lowest sound pressure levels) exceeds twice the number of key measurement points, or
- b** the source radiates noise with a high directivity, or

- c the noise from a large source is radiated only from a small portion of the source, e.g. the openings of an otherwise closed machine.

If condition **a** exist, additional microphone positions shall be used. For the microphone array on the parallelepiped, the numbers of microphones are increased as shown on the next page by increasing the number of equally sized rectangular partial areas.

If conditions **b** or **c** exists, additional measurement positions on the measurement surface in the region of high noise radiation shall be used. Details on this are given in the ISO3746.

### Reducing the number of positions

The number of microphones positions can be reduced if preliminary investigations for a particular family of machines show that by using the reduced number of microphone positions, the determined surface sound pressure levels do not deviate more than 1 dB from those determined from measurements over the complete set of microphone positions in accordance with the procedures described above.

An example is when the radiation pattern is shown to be symmetrical.

The overhead position(s) may be omitted for safety reasons, if so stated in the relevant noise test code.

### Mic. positions – one reflecting plane

Each plane of the measurement surface shall be considered on its own and so subdivided that the result is the smallest possible number of equal sized rectangular partial areas with a maximum length of side equal to  $3d$  (see the Fig. to the right). The microphone positions are in the centre of each partial area. In this way the other positions shown overleaf are obtained.

### More than one reflecting plane

For a source installed adjacent to more than one reflecting plane, reference shall be made to the figures shown on this page spread for the purpose of defining a suitable measurement surface. Microphone positions are as shown in the figures.

Procedure for fixing the specified microphone positions where a side of the measurement surface exceeds  $3d$ .

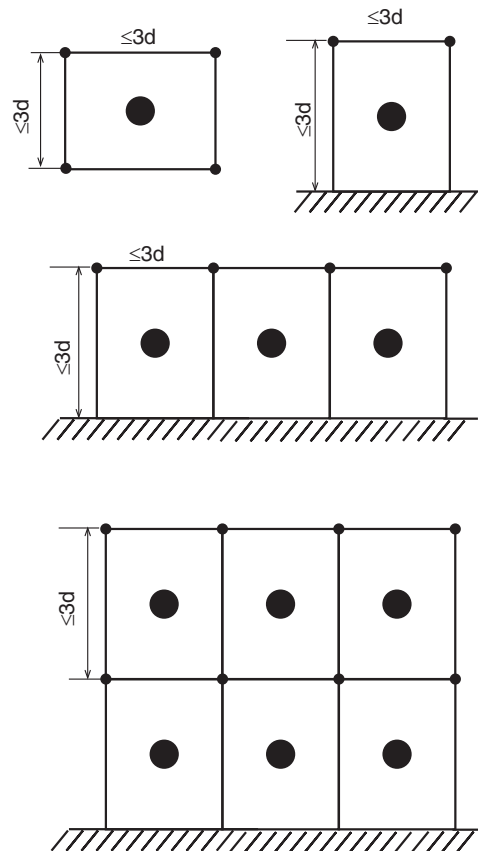

Example of a measurement surface and microphone positions for a small machine...

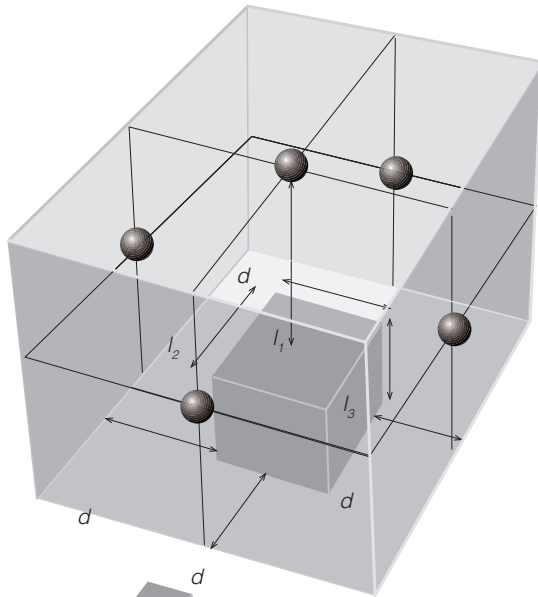

Reference box



Microphone position

Microphone placement with four microphones for floor-standing appliances placed against a wall...

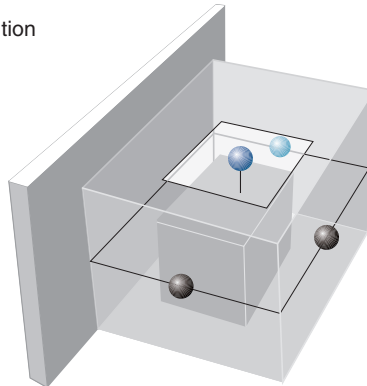

...and an example of microphone placement for a larger machine. Details on the microphone positioning can be found in the ISO 3746.

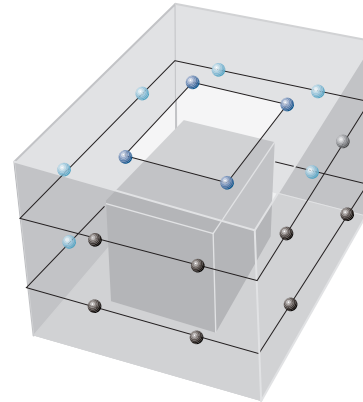

...and three microphones for floor-standing appliances placed in a corner.

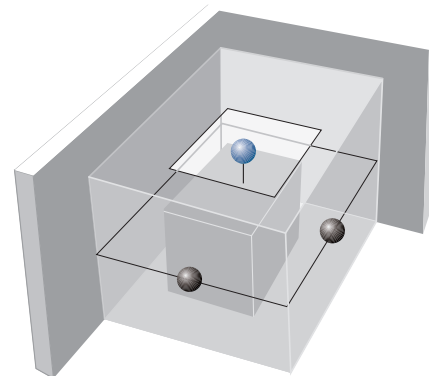

## Sound power – acoustic environment requirements

A test area outdoors or an ordinary room will provide a suitable environment, if the requirements given in the Annex A of the ISO 3746 and briefly outlined here, are satisfied.

Reflecting objects other than reflective plane(s) shall be removed to the extent possible from the vicinity of the machine under test. A test site shall ideally provide a measurement surface which lies

- a inside a sound field that is essentially undisturbed by reflections from nearby objects and the room boundaries, and

- b outside the near field of the sound source under test.

For the purpose of the survey method (the method described here), the measurement surface is considered to lie outside the near field if the measurement distance from the source under test is equal to or greater than 0.15 m.

When measuring in accordance with the ISO 3746, the environmental correction factor  $K_2$  is obtained from this graph by entering the abscissa with the appropriate value of  $A/S$

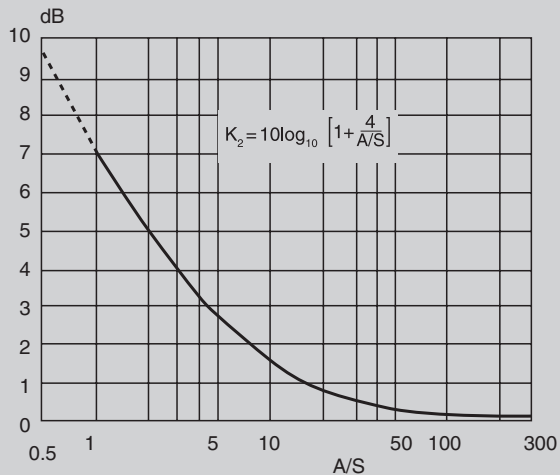

$\alpha$	Description of Room
0.05	Nearly empty room, smooth hard walls made concrete, brick, plaster or tile
0.1	Partly empty room, room with smooth walls
0.15	Room with furniture, rectangular machinery or industrial room
0.2	Irregularly shaped room with furniture, irregularly shaped machinery or industrial room
0.25	Room with upholstered furniture, machinery or industrial room with small amount of acoustical material
0.35	Room with acoustical material on both ceilings and walls
0.5	Room with large amounts of acoustical material on ceiling and wall



### Calculating the A (Absorption Area):

The value of the mean acoustic absorption coefficient  $\alpha$  is estimated by using the above table. The value of A is then given, in  $m^2$  by  $A = \alpha S_v$  in which  $S_v$  is the total area of the surface of the test room (walls, ceiling and floor) in  $m^2$ .



## Specific requirements

Examples of permitted reflecting planes outdoors include compacted earth, artificial surfaces such as concrete or sealed asphalt, while for indoor measurements, the reflecting plane is usually the floor.

Take care to ensure that the reflecting surface does not radiate any appreciable sound energy due to vibration.

The reflecting surface must be larger than the projection of the measurement surface on it.

The sound absorption coefficient (details on this are given in the ISO 354) of the reflecting plane should preferably be less than **0.1** over the frequency range of interest. This requirement is usually fulfilled when outdoor measurements are made over concrete, sealed asphalt or stone surfaces. For reflecting planes with higher sound absorption coefficient, e.g. grass- or snow-covered ground, the measurement distance shall not exceed 1 m. For indoor measurements, wooden and tile floors are also permitted.

No reflecting parts that are not part of the source under test shall be located within the measurement surface.

## The $K_{2A}$ factor

The environmental correction factor  $K_{2A}$  accounts for the influence of undesired sound reflections from room boundaries and/or reflecting object near the source under test.

The magnitude of this factor depends principally on the ratio of the sound absorption area  $A$  of the test room to the area  $S$  of the measurement surface. The magnitude does not depend strongly on the location of the source in the test room.

In the ISO 3746, the environmental correction factor  $K_{2A}$  is given by

$$K_{2A} = 10 \lg [1 + 4(S/A)] \text{ dB}$$

where

$A$  is the equivalent sound absorption area in the room at 1 kHz, in  $\text{m}^2$

$S$  is the measurement surface area, in  $\text{m}^2$ .

Environmental corrections as a function of  $A/S$  are illustrated on the previous page.

## Approximate method

The mean sound absorption coefficient  $a$  of the surface of the room may be estimated using the table shown on the next page. The value  $A$  is given, in  $\text{m}^2$ , by the formula:

$$A = a \cdot S_v$$

in which,

$a$  is the mean sound absorption coefficient, given for A-weighted quantities in the table a few pages ahead.

$S_v$  is the total area of the boundary surfaces of the test room (walls, ceiling and floor), in  $\text{m}^2$ .

## Using reverberation time instead

The classic definition of absorption area is the well-known Sabine's formula:

$$A = 0.161 \frac{V}{T}$$

in which,

V is the volume of the room

T is the reverberation time of the room.

If your Nor140 is equipped with the optional extension 9 reverberation time measurements, you may use this to calculate the absorption as follows:

$$K_{2A} = 10 \log[1 + 4S/A] \quad [\text{dB}]$$

$$K_{2A} = 10 \log[1 + 4(S \times T)/(0.163 \times V)] \quad [\text{dB}]$$

based on an actual reverberation time measurement.

### Test room qualification requirements

For the measurement surface in a test room to be satisfactory for measurements in accordance with the requirements of ISO 3746, the ratio of the sound absorption area **A** to the area **S** of the measurement surface shall be equal to or greater than 1, that is  $A/S \geq 1$ . The larger the ratio **A/S** is, the better.

If you cannot meet this requirement, a new measurement surface shall be chosen. This surface shall have a smaller total area, but shall still lie outside the near field.

Alternatively you may improve the **A/S** by adding sound-absorbing materials to the test room.

If this does not help, the test room cannot be used for ISO 3746 measurements!

### Measuring the sound power

The sound power calculation extension enables you to make a complete sound power measurement, resulting in an  $L_{WA}$  value (the A-weighted sound power level) of any test object in accordance with ISO 3746 and related Standards. This means that when equipped with

a Nor140 you may test the  $L_{WA}$  of new products for the European **CE** labelling in the production area (*in-situ*), rather than in a laboratory (*in-vitro*).







### Making measurements

Before you start to make sound power measurements we recommend that you familiarise yourself with how to make regular sound level measurements.

#### Then do as follows:

- 1 Once the test object is properly placed, start the setup procedure by selecting measurement duration as described in *Making simple sound measurements*.
- 2 Press **SETUP** followed by 4. The instrument will now enter the measurement control display.
- 3 The Nor140 allows 1–40 microphone positions to be measured. The initial measurement control display shows 8 positions, but this may be extended to further pages covering the positions 9–40 by pressing the **▶** key (“next page”).
- 4 At the bottom of the screen, the averaged sound pressure level based on the measured microphone positions, is displayed. Each microphone position is selected by moving the field cursor using the **◀** or **▶** keys to the selected position, and then pressing the **START** key. The screen will show the normal measurement display during a measurement, and return to the control screen and display the measured  $L_{EQ,A}$  value for the measured positions at the end of each measurement.

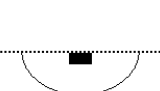
The measurement surface can be either a hemisphere or a parallelepiped (cuboid). In addition you may choose between different locations of your test object, i.e. on the floor, up against a hard reflecting wall or in a corner...

<b>Surface: P</b>  L: 1.00 m W: 1.00 m H: 1.00 m Dis: 1.00 m K2: 2.0 dB <b>S:</b> 33.00m <sup>2</sup> 	<b>Surface: Pw</b>  L: 1.00 m W: 1.00 m H: 1.00 m Dis: 1.00 m K2: 2.0 dB <b>S:</b> 20.00m <sup>2</sup> 	<b>Surface: Pc</b>  L: 1.00 m W: 1.00 m H: 1.00 m Dis: 1.00 m K2: 2.0 dB <b>S:</b> 12.00m <sup>2</sup> 	<b>Surface: H</b>  Rad: 1.50 m K2: 2.0 dB <b>S:</b> 14.13m <sup>2</sup> 	<b>Surface: Hw</b>  Rad: 1.50 m K2: 2.0 dB <b>S:</b> 7.06m <sup>2</sup> 	<b>Surface: Hc</b>  Rad: 1.50 m K2: 2.0 dB <b>S:</b> 3.53m <sup>2</sup> 
-----------------------------------------------------------------------------------------------------------------------------------------------------------------------------------------------------------------	------------------------------------------------------------------------------------------------------------------------------------------------------------------------------------------------------------------	------------------------------------------------------------------------------------------------------------------------------------------------------------------------------------------------------------------	--------------------------------------------------------------------------------------------------------------------------------------------------------------------------	----------------------------------------------------------------------------------------------------------------------------------------------------------------------------	----------------------------------------------------------------------------------------------------------------------------------------------------------------------------

The background noise measurement display...

Although the Nor140 lets you measure the background noise level in up to 40 positions, the background noise level will in most situations vary so little from one microphone position to another that it is, for most cases, sufficient to measure the background noise level for one typical microphone position.

<b>Pos:</b>	BGN
1:	--
2:	--
3:	--
4:	--
<b>5:</b>	44.9
6:	--
7:	--
8:	--
<b>ΣBGN:</b>	44.9

Use (next) and (previous) to go between pages.

The measurement control display...

Although only 8 microphone positions are shown, there are further "pages" so that a total of 40 microphone positions can be covered. Use the key.

<b>Pos:</b>	LeqA
1:	44.0
2:	77.5
3:	59.0
<b>4:</b>	56.9
5:	--
6:	--
7:	--
8:	--
<b>ΣLeqA</b>	71.6



If you need to know which of the frequency bands that contribute the most to the calculated  $L_{WA}$  value, switch to global frequency mode, make a measurement and press the **A-Prew** key. The spectrum will now appear a-weighted on the screen (purely a display function, the measured data are not affected) and the frequency band(s) contributing the most should now be easy to spot.

After a successful set of measurements has been made, the results are presented like this upon pressing the **TBL** key.

<b>RESULTS</b>
<b>Surface: Hc</b>
<b>S:</b> 3.53m <sup>2</sup>
<b>LeqA:</b> 71.6
<b>BGN:</b> 44.9
<b>K1:</b> 0.0
<b>K2:</b> 2.0
<b>Imp:</b> Yes
<b>PeakC:1</b> 15.5
<b>L<sub>WA</sub>:</b> 75.1

The results can also be printed out. Turn to *Making hardcopies* for a sample.

The environmental correction factor  $K_2$  accounts for the influence of undesired sound reflections from room boundaries and/or reflecting objects near the source under test. The magnitude of this environmental correction factor depends principally on the ratio of the sound absorption area  $A$  of the test room to the area  $S$  of the measurement surface. The magnitude does not depend strongly on the location of the source in the test room.

When measuring in accordance with the ISO 3746, the environmental correction factor  $K_2$  is obtained from this graph by entering the abscissa with the appropriate value of  $A/S$

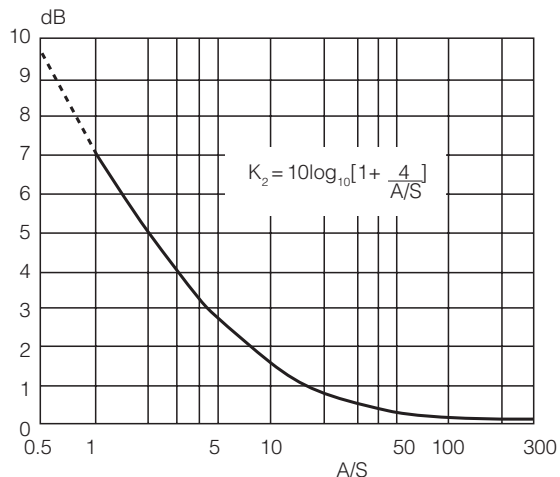

$\alpha$	Description of Room
0.05	Nearly empty room, smooth hard walls made concrete, brick, plaster or tile
0.1	Partly empty room, room with smooth walls
0.15	Room with furniture, rectangular machinery or industrial room
0.2	Irregularly shaped room with furniture, irregularly shaped machinery or industrial room
0.25	Room with upholstered furniture, machinery or industrial room with small amount of acoustical material
0.35	Room with acoustical material on both ceilings and walls
0.5	Room with large amounts of acoustical material on ceiling and wall

**Calculating the A:** The value of the mean acoustic absorption coefficient  $\alpha$  is estimated by using the above table or by means of reverberation time measurements. The value of  $A$  is then given, in  $m^2$  by  $A = \alpha \times S_v$  in which  $S_v$  is the total area of the surface of the test room (walls, ceiling and floor) in  $m^2$

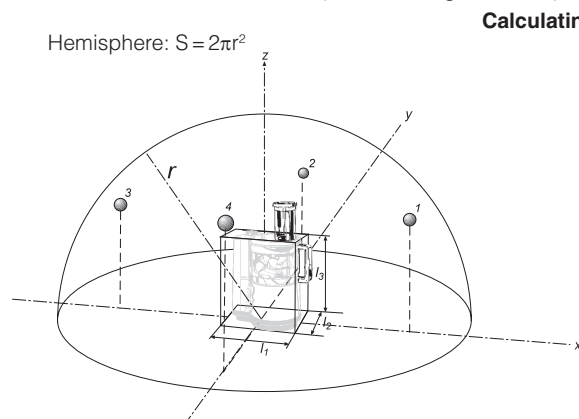

**Calculating the S:**

Parallelepiped:  $S = 4(ab + bc + ca)$

$$a = \frac{l_1}{2} + d$$

$$b = \frac{l_2}{2} + d$$

$$c = \frac{l_3}{2} + d$$

$l_1, l_2, l_3$  are the dimensions of the rectangular reference parallelepiped

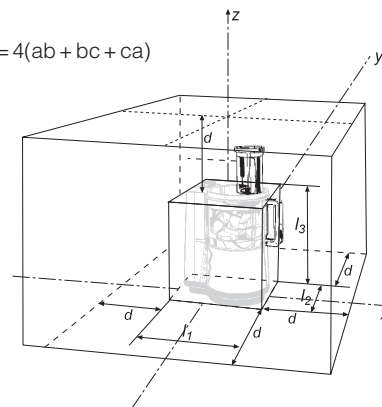



Note that the last measurement with individual meas. for each pos, as well as setup of measurement condition, is retained even after leaving and re-entering the SP mode. To delete the current data, move the cursor to the SumLeqA pos and press **DEL**. To delete just the measurement data from individual pos., move the cursor to the position needed and press **DEL**.



Note that when moving to the next "page", eg. meas no.9-16, by pressing the **>/** key, the cursor is placed on the SumLeqA pos. You need to key upwards with **<** to get to pos. 9. This is because when moving between pages, the current cursor pos. is retained

## Background noise

A background noise measurement is required to have the instrument calculate the background noise correction  $K_1$  for you. On pressing the **FUNC** key, the background noise measurement control display is displayed. This test follows the exactly the same procedures as the sound power measurements.

However, the background noise level will in most situations vary little from one microphone position to another, it will therefore normally be enough to measure the background noise level for one typical microphone position.

### To toggle between the measurement control display and the background noise measurement control display:

- Use the **FUNC** key.

## Measurement surface

The sound power calculation requires the operator to select the correct measurement surface.

### To select the right measurement surface:

- 1 Press the **SETUP** key and choose the corresponding selection in the sound power setup menu. The selected surface is indicated by H for Hemispherical and P for Parallelepiped with an additional W or C for test objects placed against a wall or in a corner. The selected surface is also indicated by a simple diagram.
- 2 Depending on the selected surface, the measurement radius or the distance from the reference box (i.e. the minimum box that fits around the test object) must be keyed in. The calculated area  $S$  of the total measurement surface will then be displayed.
- 3 Finally, key in the acoustic environment correction  $K_2$ .

## Sound power results

Based on the averaged sound pressure level of all the microphone positions, the measured background noise level and the selections and corrections made in the sound power setup menu, the Nor140 will display the final  $L_{WA}$ .

### To see the sound power calculation results:

- Press the **TBL** key.
- In addition to the overall results, the impulsive noise values, the  $L_{PEAKC}$  (or  $L_{PEAKZ}$ ) level and the noise directivity of the test object for all microphone positions are found by sequential pushes of the **TBL** key.

The results may also be copied to a printer. The report includes necessary spaces for all the required measurement information to be written directly on the report by the user. On a second page, the individual results for each of the microphone positions are printed. See *Making hardcopies* for more on this.

On the previous pages you will find display examples together with the calculation procedure for the determination of the environmental correction factor  $K_2$ , which has been repeated from the previous chapter for your convenience.

# Building Acoustics

## Introduction

When equipped with the required program options, Nor140 is well suited for measurement of building acoustics in the form of measuring reverberation time and sound insulation. The Building Acoustic option is option 11 in the instrument.

The Building Acoustic – Survey mode allows measurement of building acoustic parameters according to the International Standard ISO 10052 (2004-12): Acoustics – Field measurement of airborne and impact sound insulation and of service equipment sound – Survey method. These measurements are made in full octave bands and the results are reported for each band as well as frequency-weighted values according to ISO 717-1 and ISO 717-2.

The Building Acoustic – Engineering method mode allows measurement of building acoustic parameters according to the ISO 140 series of International Standards. Measurements are made in one-third octave bands and the results are reported for each band as well as frequency-weighted values according to ISO 717-1 and ISO 717-2.

The mode is entered by pressing **MODE** and select “**4 BuildAc**”. The BA mode menu then appears. Press **1** or **2** for selecting the measurement of either airborne or impact sound insulation according to the survey method. Press **3** or **4** for selecting the measurement of either airborne or impact sound insulation according to the engineering method (see figure next page).

In the rest of this manual we often talk about

BA	for Building Acoustics
Survey	for Survey Methods
Engineering	for Engineering Methods that gives better accuracy
Airborne	for Airborne Sound Insulation calculations
Impact	for Impact Sound Insulation calculations
Facade	for Facade Sound Insulation calculations just for simplicity.



You have the choice to start measurement within the Building Acoustic mode or to make level measurement in Normal mode and reverberation time measurements in Reverberation mode. Store the result and retrieve them later in Building Acoustic mode for calculating the final result.

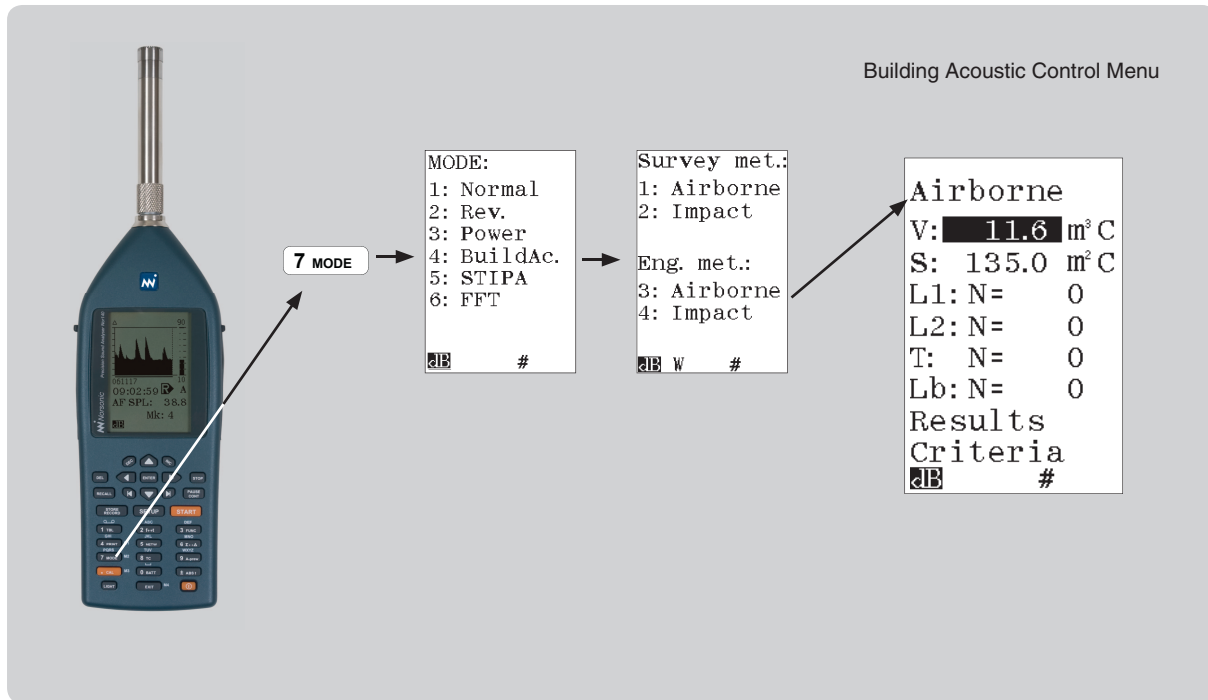

For measurement of facades, use “Airborne” as described in sections covering *Facade insulation*.

At any stage – except in the results display, the instrument may be brought back to normal operation by pressing **MODE** again and select the mode “1 Normal”.

If you want to start over again or change from “Airborne” to “Impact” task (vice versa), you have to enter through the general **MODE**-menu.



**Terms and definitions for airborne sound insulation**

The following terms are used in the display:

- L<sub>1</sub> average sound pressure level in the source room during excitation [dB]
- L<sub>2</sub> average sound pressure level in the receiving room during excitation [dB]
- L<sub>b</sub> average background sound pressure level in the receiving room [dB]
- T reverberation time in the receiving room [s]
- T<sub>0</sub> reference reverberation time equal to 0,5 s
- k reverberation index [dB]
- D<sub>iff</sub> level difference [dB]
- D<sub>nT</sub> standardised level difference [dB]
- D<sub>n</sub> normalised level difference [dB]
- R' apparent sound reduction index [dB]
- V volume of the receiving room [m<sup>3</sup>]
- S area of the partition between the source and receiving room [m<sup>2</sup>]
- A<sub>0</sub> reference absorption area equal to 10 m<sup>2</sup>.

The relations between the quantities are given by the following equations:

$$k = 10 \cdot \lg \left( \frac{T}{T_0} \right)$$

$$D_{diff} = L_1 - L_2$$

$$D_{nT} = L_1 - L_2 + k$$

$$D_n = L_1 - L_2 + k + 10 \cdot \lg \left( \frac{A_0 T_0}{0,16 \frac{s}{m} \cdot V} \right)$$

$$R' = L_1 - L_2 + k + 10 \cdot \lg \left( \frac{ST_0}{0,16 \frac{s}{m} \cdot V} \right)$$

The values are calculated for each octave or one-third octave band. For D<sub>nT</sub>, D<sub>n</sub> and R', a single-number value is also calculated. The value corresponds to the 500 Hz value for the reference curve after shifted it in accordance with the method specified in ISO 717-1 or ISO 717-2, as appropriate. The spectral adaptation terms (C and C<sub>tr</sub>) are also calculated according to the same standards.

### Terms and definitions for impact sound insulation

The following terms are used in the display:

- L average sound pressure level in the receiving room during excitation [dB]
- $L_b$  average background sound pressure level in the receiving room [dB]
- T reverberation time [s]
- $T_0$  reference reverberation time equal to 0,5 s
- k reverberation index [dB]
- $L_{nT}$  standardised impact sound pressure level [dB]
- $L_n$  normalised impact sound pressure level [dB]
- V volume of the receiving room [ $m^3$ ]
- $A_0$  reference absorption area equal to  $10 m^2$ .

The relations between the quantities are given by the following equations:

$$k = 10 \cdot \lg \left( \frac{T}{T_0} \right)$$

$$L_{nT} = L - k$$

$$L_n = L - k - 10 \cdot \lg \left( \frac{A_0 T_0}{0,16 \frac{s}{m} \cdot V} \right)$$

The values are calculated for each frequency band. For

$L_{nT}$  and  $L_n$ , a single-number value is also calculated. The value corresponds to the 500 Hz value for the reference curve after shifted it in accordance with the method specified in ISO 717-2.

### Survey and engineering methods

Survey measurements according to the ISO 10052 standard are made in octave bands. Option 1, Octave-frequency analysis, is therefore required in addition to Option 11. The procedure described in the International standard specifies how to measure sound insulation by measuring levels in octave-bands and estimating the acoustic absorption (reverberation time). Service equipment sound – is measured in the normal mode of operation.

Engineering method measurements are made according to the standards ISO 140-4: Field measurements of airborne sound insulation between rooms, ISO 140-5: Field measurements of airborne sound insulation of facade elements and facades and ISO 140-7: Field measurements of impact sound insulation of floors are made in one-third octave bands. Option 3, One-third-octave frequency analysis and Option 9, Reverberation Time measurements, are therefore required in addition to Option 11. The procedure described in the International standard specifies how to measure sound insulation by measuring levels and reverberation time in one-third octave bands.

## Airborne sound insulation

### General

When airborne sound insulation between rooms is measured, one of the rooms is designated the source room and the other the receiving room. A stationary sound field is generated in the source room by a suitable loudspeaker.

If a facade is measured, the loudspeaker is placed outdoors and the outside of the building is then acting as the source room. The description made here refers to the sound insulation between rooms, but may also be adapted to the measurement of facades.

### Noise excitation

The measurements require broadband or band filtered noise to be used for the excitation. The noise may be generated by the instrument if option 10, Noise generator, is installed. Sometimes it will be convenient not to have a cable between the instrument and the loudspeaker for the excitation. This may be achieved by using a radio-transmitter for the noise signal (contact Norsonic for more information) or to use a power amplifier with an internal noise generator such as the Nor280. Another alternative is to play a music-CD with recorded noise. Norsonic can supply a CD with the required excitation signals (Nor1033).

### Measurement of sound level

As stated in the standards, the spatial average of the sound level in the room is required. For survey measurements this may be achieved by measuring the level while moving the sound level meter (microphone) around in a figure-of-eight trajectory. Recommended measuring time is 30 seconds. For the engineering

method point by point measurements has to be applied and the instrument will calculate the averaged level.

The level measurements may be performed in the normal mode of operation and stored for later processing, or alternatively, the measurements may be started from the calculation menu when the results are required for the calculation.

### Measurement of reverberation time

For a survey measurement according to ISO 10052, the corrections for the acoustic absorption may either be based on measurement of the reverberation time or based on estimation based on room type, type of surface and furniture. Both methods are implemented. For engineering measurements according to the ISO 140 series of standards, the reverberation time has to be measured.

If a measurement is required, the reverberation measurement may be performed in the reverberation mode of operation and the result stored for later processing (MODE 2. Rev.). Alternatively, the measurement may be started from the calculation menu when the result is required for the calculation.

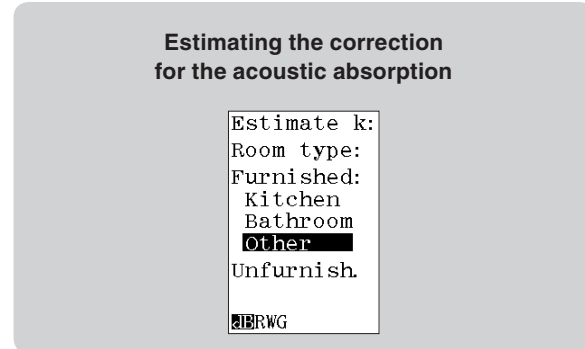
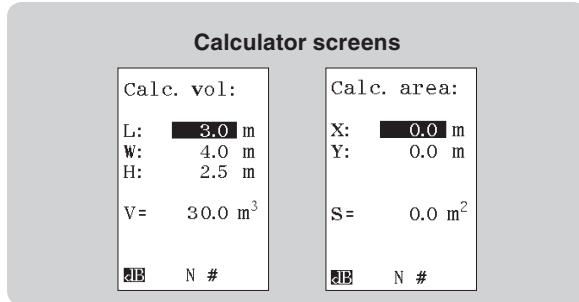

### Calculating the Airborne and insulation according to the Survey Method

After selecting the Building Acoustic mode, select 1 “Airborne” in the display shown on adjacent figure.

Enter the value for the room volume “V” and press **ENTER** or move the field cursor to “C” and press **ENTER** for a calculator.

The calculator allows you to enter the length, width and height of the room in metres in order to calculate the volume. After the volume is entered, the field cursor automatically moves to the next parameters to be entered: Area “S”. Enter the value or use the calculator in a similar way.

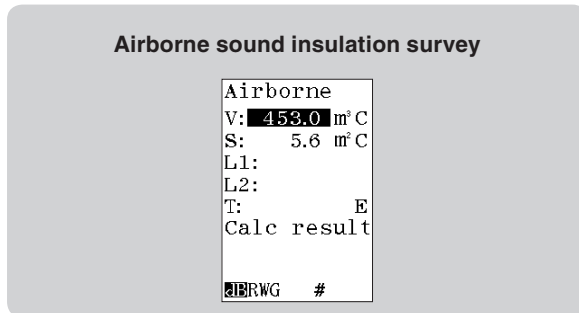

The field cursor automatically moves between the fields as values are entered. If you want to adjust any previously entered value, use the cursor keys to move the field cursor to the required parameter.

The next set of values to be entered is the sound levels in the source room  $L_1$  for each octave-band. Move the cursor to the L1: field. Recall a measurement by using the **RECALL** key or press **START** for starting a measurement. The values are automatically stored. The sound level meter (or its microphone connected via an extension cable) should be moved as specified in the measurement standard to obtain the spatial average.

The set of levels in the receiver room,  $L_2$ , is obtained in a similar way.

### Displaying of results

The acoustic losses of the receiving room used in the calculation may be obtained by measurement, by recalling measured value, or by estimation. The instrument must be equipped with the option for reverberation time measurements in order to allow the measurement option to be used. If the optional noise generator is installed it may be used for the excitation,

otherwise impulse method has to be used. To start a measurement, press **START** when the field cursor is in the field for reverberation time marked “T”. Alternatively move the cursor to the “E” field at the end of the line and press **ENTER** to activate the “Estimate k:” screen where you can select room type.

When you move the field cursor to the field “Calc result” and press **ENTER**, the following functions are calculated for each of the octave-bands 125 Hz to 2000 Hz:

- The normalised level difference  $D_n$
- The standardised level difference  $D_{nT}$
- The apparent sound reduction index  $R'$
- The source room level  $L_1$
- The receiver room level  $L_2$
- The reverberation index  $k$
- The reverberation time  $T$

For the values  $D_n$ ,  $D_{nT}$  and  $R'$ , a frequency weighted value according to ISO 717-1 is also calculated together the correction terms  $C_{125-2000}$  (marked as  $C$ ) and  $C_{tr,125-2000}$  (marked as  $C_{tr}$ ). Pressing the **FUNC** key repeatedly will display the different functions. The weighted values are all rounded to the nearest dB.



**Note** that you have to be in the menu for entering values before you are able to select another mode.

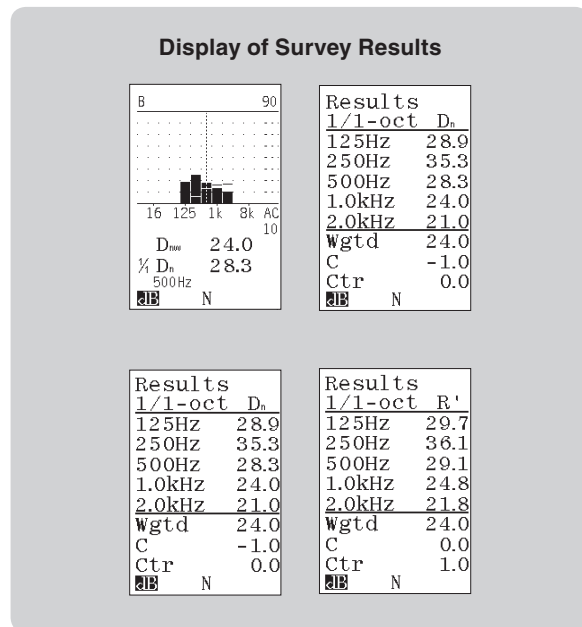

If you want to go back to the calculation menu just press **ENTER**. Press the **MODE** button if you want to return to normal mode of operation.

### Calculating the Airborne sound insulation according to the Engineering method

After selecting the Building acoustic mode, select “3: Airborne”. Enter the value for the room volume “V” and press **ENTER**, or move the field cursor to “C” and press **ENTER** for a calculator. The calculator allows you to enter the length, width and height of the room in metres in order to calculate the volume. After the volume is entered, the field cursor automatically moves to the next parameters to be entered: Area “S”. Enter the value or use the calculator.

The field cursor automatically moves between the fields as values are entered. If you want to adjust any

previously entered value, use the arrow keys to move the field cursor to the required parameter.

### Source room level

The next set of values to be entered is the sound levels in the source room L1 for each one-third octave. Recall a previously made measurement by using the **RECALL** key, or press **START** for starting a measurement. Measured values are automatically stored.

You are prompted to accept the recalled or measured values as a part of the averaging process. Press **ENTER** (alternatively **STORE**) to accept or **EXIT** (alternatively **DEL**) if you don't want to accept.

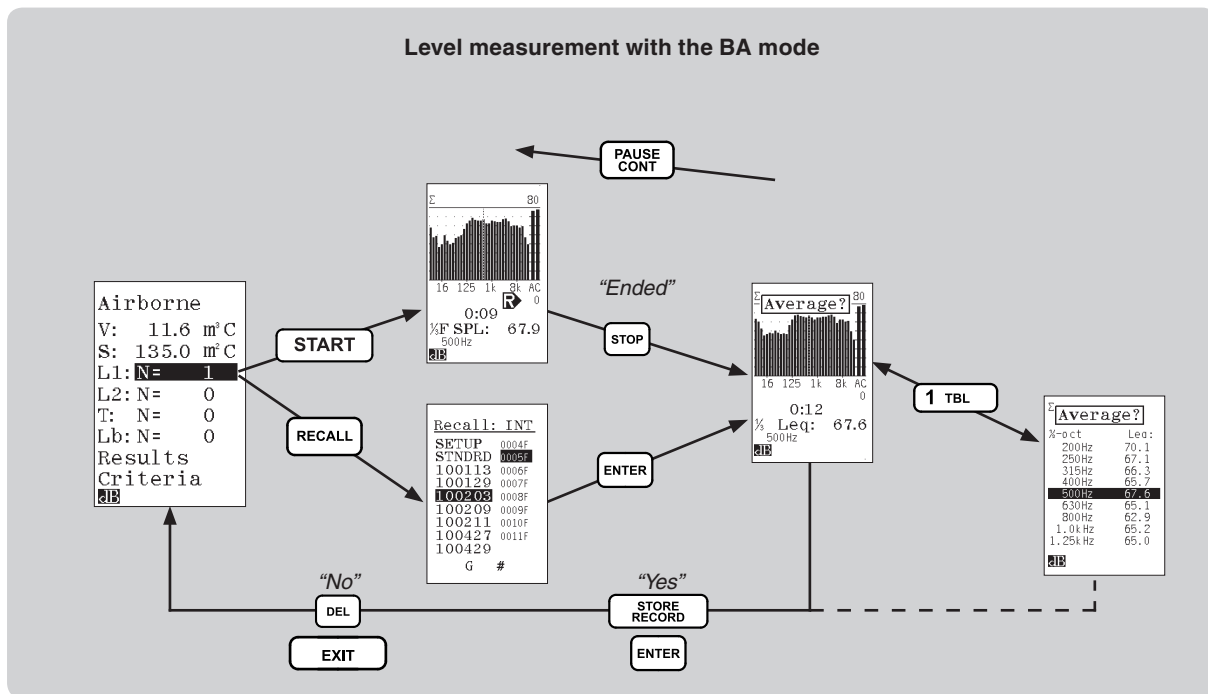

You may repeat the catching of data to obtain the averaged results from more measurements. The number of measurements that has been accepted for the averaging is displayed by a number N. Press the **TBL** key to display the averaged levels.

The averaged level L is obtained according to the following formula where  $L_k$  is the result from each of the N values:

$$L = 10 \lg \left\{ \frac{1}{N} \sum_{k=1}^N 10^{L_k/10} \right\} \text{ dB}$$

### Receiving room level

The average level in the receiver room,  $L_2$ , is obtained in a similar way.

When looking at the receiving room levels they are here shown without correction for background noise.

### Background noise

Also the average background noise level,  $L_b$ , can be measured. Entering values for the background noise level is optional. If the level in the receiving room is more than 10 dB above the level of the background noise, no corrections will be made and the final result will be independent of having measured a background level or not. However, if the difference between the averaged level in the receiving room and the background noise is between 6 dB and 10 dB, a corrected level for the receiving room,  $L_{2C}$ , will be used in the calculation as described in ISO 140-4:

$$L_{2C} = 10 \lg \left\{ 10^{L_2/10} - 10^{L_b/10} \right\} \text{ dB}$$

The correction is limited to maximum 1,3 dB corresponding to a measured level in the receiving room 6 dB above the background level.

### Reverberation time

The acoustic losses of the receiving room used in the calculation may be obtained by measuring the reverberation time or by recalling earlier measured values. See the paragraph describing measurement of reverberation time. If the optional noise generator is installed it may be used for the excitation, otherwise impulse method has to be used. To start a measurement, press **START** when the field cursor is in the field for reverberation time marked "T".

### Display of results

When the required information has been entered, the cursor will automatically be placed in the field for calculation of the final result. If you are satisfied with the entered values press **ENTER**, or if you want to make any correction, move the field cursor to the required field and enter the corrected values or press **DEL** to clear averaged values.

#### Display of measurement result

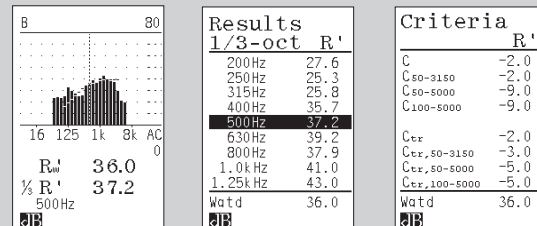

**Note:** that you have to be in the menu for entering values before you are able to select another mode.

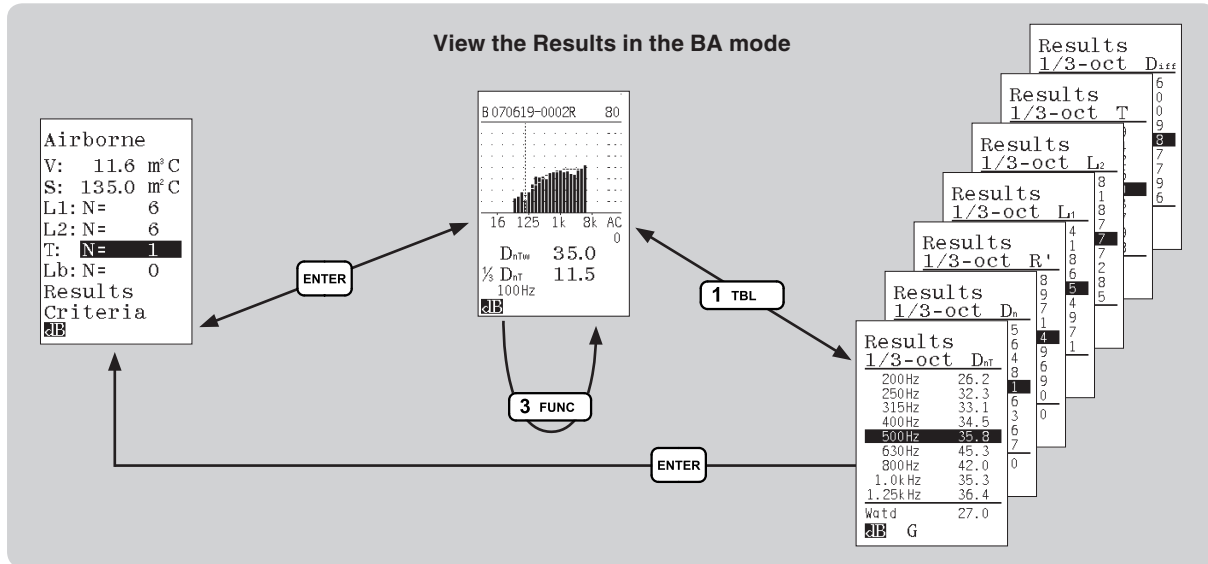
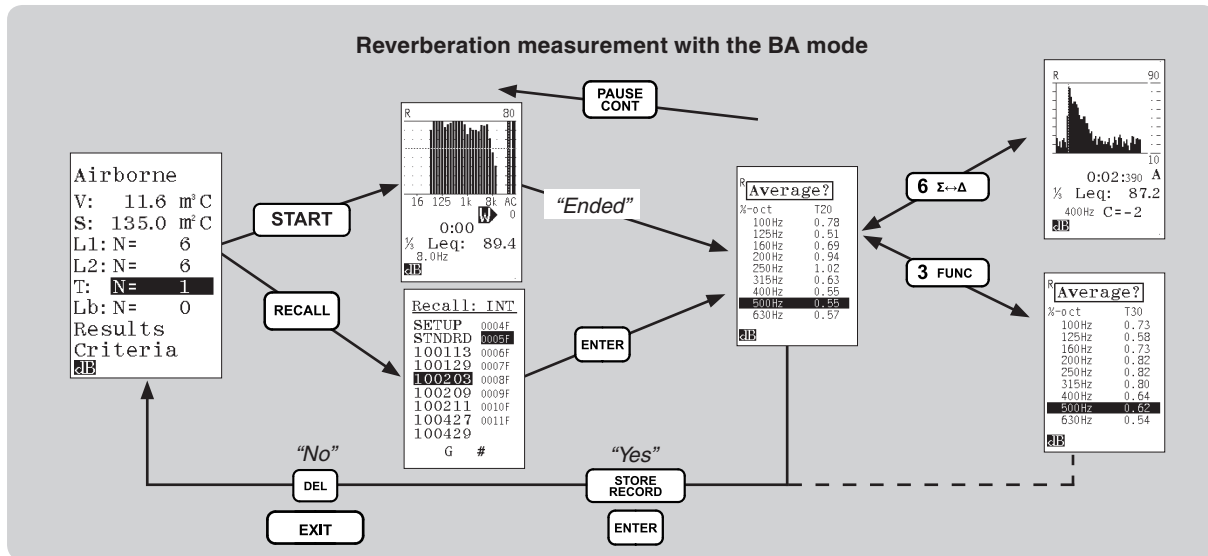



When you move the field cursor to the field “Results” and press **ENTER**, the following functions are calculated for each of the one-third octave-bands 50 Hz to 5000 Hz:

- The normalised level difference  $D_n$
- The standardised level difference  $D_{nT}$
- The apparent sound reduction index  $R'$
- The source room level  $L_1$
- The receiver room level  $L_2$
- The level difference  $D_{iff}$
- The reverberation time  $T$

Note that  $L_2$  is now the level in the receiving room corrected for the background noise and thus may deviate from the entered averaged value.

### Spectrum adaptation terms

For the values  $D_n$ ,  $D_{nT}$  and  $R'$ , a frequency weighted value according to ISO 717-1 is also calculated together with the spectrum adaption terms  $C_{100-3150}$  (marked as C),  $C_{50-3150}$ ,  $C_{50-5000}$ ,  $C_{100-5000}$ ,  $C_{tr, 100-3150}$  (marked as  $C_{tr}$ ),  $C_{tr, 50-3150}$ ,  $C_{tr, 50-5000}$  and  $C_{tr, 100-5000}$ . Pressing the **FUNC** key repeatedly will display the different functions. The weighted values are all rounded to the nearest dB. If you want to go back to the calculation menu just press **ENTER**.

Press the **MODE** button if you want to return to normal mode of operation.

### Store and recall

You may store the result by pressing **STORE**. The file is automatically designated with the next free file number suffixed with the letter “B” indicating building acoustics.

It is possible to save individual measurement files additionally to the overall building acoustic file. This features is selected if the storage mode is set to “AUTO” in the SETUP menu.

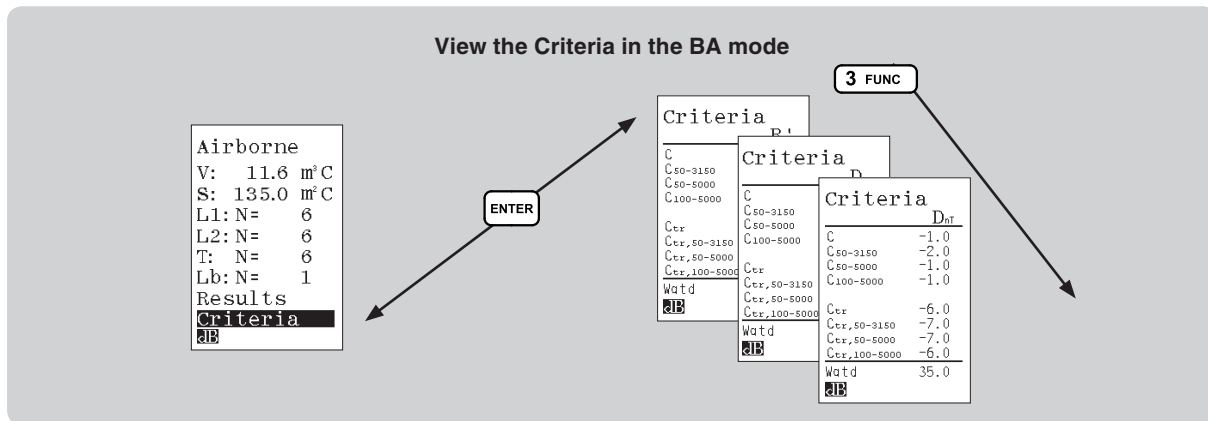

### Averaging levels or level-differences

When you measure the levels as described and make the average of the results, the levels in the source room are averaged to obtain the mean value for the source room. The averaged level for the receiving room is obtained in a similar way. The level difference is calculated as the difference of the averaged levels. However, for some applications the measured *differences* from multiple sets of measurements should be averaged. This may be obtained in the following way:

Measure the level in the source and receiving room,  $L_1$  and  $L_2$ , and store the result. Move the cursor to the RESULT field and press **DEL**. Then confirm that all averaged values shall be deleted. Repeat the meas-

urements of levels in the source and receiving room, as many times as requested including the required number of reverberation time and background measurements in at least one of these repetitions. When all measurements are finished, make **RECALL** of the first serie. Move the cursor to one of the fields  $L_1$ ,  $L_2$ , T or  $L_b$  and press **RECALL** for adding the initial result and press **ENTER**. Enter other set of measurements in a similar way. After each recall the displayed number of differences ND is increased as shown below. No values will be given for the individual levels  $L_1$ ,  $L_2$  or  $L_b$ . The results are calculated and displayed as before.

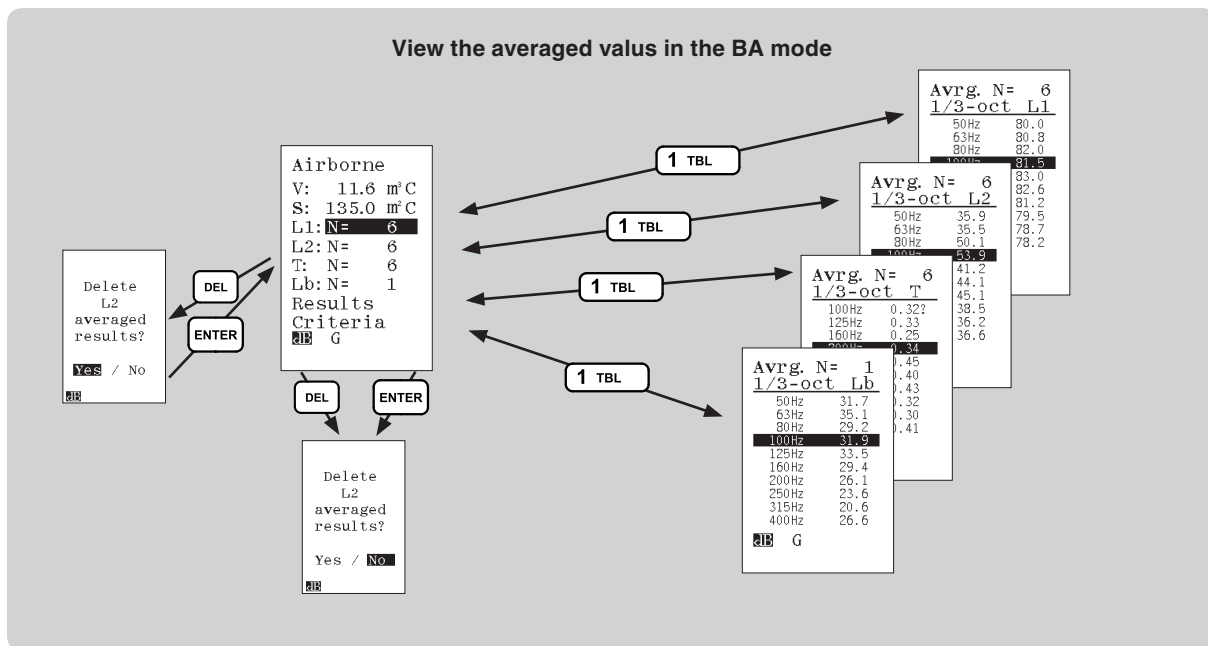

## Equalizing the excitation level

When measuring the airborne sound reduction it is in some standards (e.g. section 5.1 Airborne sound field in ISO 140.4 and ISO 10140) required that the variations in excitation spectrum is kept below certain as flat as possible.

*“The sound generated in the source room shall be steady and have a continuous spectrum in the frequency range considered. If filtering of the source signal is used, use a bandwidth of at least one-third octave. If broad-band noise is used (white noise is recommended), the spectrum may be shaped to ensure an adequate signal-to-noise ratio at high frequencies in the receiving room. In either case, the average sound spectrum in the source room, at least above 100 Hz, shall not have differences in level more than 6 dB between adjacent one-third octave bands. See ISO 10140-4 and for equivalent alternatives also ISO 18233.”*

For this reason it is a possibility to insert a software spectrum shaper in the signal path of the noise generator. This equalizer can attenuate each 1/3 octave band level up to 12 dB. This equaliser is made to follow the above mentioned requirements. If the level difference is less than 6 dB between two adjacent frequencies, nothing is done with the excitation signal with these two bands.

The equalizer must be turned on before it is used. Then a measurement is performed and the result of this measurement is used to calculate the attenuation in each band. This is an automatic shaping of the spectrum, optimised to preserve the energy of the excitation signal.

Use the **SETUP 7** key sequence to activate the Noise Generator control screen.

### Noise Generator control screen

```
Noise ctrl:
Gen: OFF
Sync: ON
Type: PINK
Gain: -10 dB
Equal: ON
Adj. equal.
G
```

Move the cursor down to the “Equal: ON / OFF” line and activate the equalizer with the Inc key. Then a new line “Adj. equal” appears, and you can move the cursor down to this line and push **ENTER** to activate the shaping adjustments. When the equalization adjustment is activated, the instrument starts a measurement (with the selected measurement time, so it can be a good idea to adjust this one before you start the equalizer, or you can stop the measurement manually after the measured spectrum seems to be stable). After this test measurement is finished, the instrument turns the noise generator off and performs a special calculation procedure trying to make the excitation signal as flat as possible. The obtained spectrum shape is stored in the instrument and can later be turned off and on as desired.

No error message is given if the max attenuation of 12 dB is insufficient for the purpose, but the excitation signal spectrum is still usable and improved with respect to the requirement of the standard.

For Reverberation time measurements, the settings for the equalizer will not be used.

## Impact sound insulation

### Impact excitation

The impact sound shall be generated by the standard tapping machine as specified in ISO 140-7: Measurement of sound insulation in building and building elements – Part 7: Field measurement of sound insulation of floors. For isotropic floors, a single position for the tapping machine near the middle of the room is sufficient for measurements according to ISO 10052. For other measurements more positions are required. Norsonic recommend the tapping machine Nor277.

### Measurement of sound level

As stated in the standards, the spatial average of the sound level in the receiving room is required. For survey measurements according to ISO 10052, this may be achieved by measuring the level while moving the sound level meter (microphone) around in a figure-of-eight trajectory. Recommended measuring time is 30 seconds. For the engineering method according to ISO 140-7, point by point measurements has to be applied and the instrument will calculate the averaged level.

The level may be measured in the normal mode of operation and the results stored for later processing. Alternatively, the measurement may be started from the calculation menu when the result is required for the calculation. Press **SETUP** to enter the menu for setting the measurement time.

### Reverberation time

For a survey measurement according to ISO 10052, the corrections for the acoustic absorption may either be based on measurement of the reverberation time or based on information about the room type, type of

surface and furniture. Both methods are implemented. For measurements according to the ISO 140 series of standards, the reverberation time has to be measured.

If a measurement is required, the reverberation time may be measured in the reverberation mode and the result stored for later processing (MODE 2. Rev.). Alternatively, the measurement may be started from the calculation menu when the result is required for the calculation.

### Calculating the Survey result

Select the building acoustic mode and press **2** for “Impact”. Enter the value for the room volume “V” and press **ENTER** or move the field cursor to “C” and press **ENTER** for a calculator. The calculator allows you to enter the length, width and height of the room in order to calculate the volume.

The field cursor automatically moves between the fields as values are entered. If you want to adjust any previously entered value, use the arrow keys to move the field cursor to the wanted parameter.

The next set of values to be entered is the sound levels in the receiver room L for each octave-band. Recall a measurement by using the **RECALL** key or press **START** for starting a measurement. If measured, the values are automatically stored. The sound level meter (or the microphone connected with an extension cable) should be moved as specified in the measurement standard to obtain the spatial average.

The acoustic losses of the receiving room used in the calculation may be obtained by measurement of the reverberation time, by recalling measured values or by estimation. The instrument must be equipped with the option for reverberation measurement in order to allow the measurement option to be used. If the optional noise generator is installed it may be used for

excitation, otherwise impulse excitation has to be used. For starting a measurement, press **START** when the field cursor is in the field for reverberation time marked "T".

If you want to estimate the absorption as described in ISO 10052, move the cursor to the field marked "E" and press **ENTER**. By specifying the type of room and the covering for walls, ceiling and floor, you are entering data corresponding to Table 3 in ISO 10052. When the required information has been entered, the cursor will automatically be placed in the field for calculation of the final result. If you are satisfied with the values press **ENTER**, or if you want to make any correction, move the field cursor to the required field and enter the corrected values.

When you move the field cursor to the field "Calc result" and press **ENTER**, the following functions are calculated for each of the octaves-bands 125 Hz to 2000 Hz:



**Note** that you have to be in the menu for entering values before you are able to select another mode.

- The normalised impact sound pressure level  $L_n$
- The standardised impact sound pressure level  $L_{nT}$
- The receiver room level  $L$
- The reverberation index  $k$
- The reverberation time  $T$

For the values  $L_n$  and  $L_{nT}$ , a frequency weighted value according to ISO 717-2 is also calculated. Pressing the **FUNC** key repeatedly will display the different functions.

You can use the **TBL** key to switch between tabular and graphical result displays. The weighted values are all rounded to the closest whole dB.

If you want to go back to the menu for calculation, press **ENTER**.

Press the **MODE** button if you want to return to normal mode of operation.

### Calculating the impact sound insulation according to the Engineering method

Use the **MODE** button to select the building acoustic mode and press **4** for "Impact". Enter the value for the room volume "**V**" and press **ENTER** or move the field cursor to "**C**" and press **ENTER** for a calculator. The calculator allows you to enter the length, width and height of the room in order to calculate the volume.

The field cursor automatically moves between the fields as values are entered. If you want to adjust any previously entered value, use the arrow keys to move the field cursor to the wanted parameter.

### Receiving Room Level

The next set of values to be entered is the sound levels in the receiver room  $L$  for each one-third octave-band. Recall a measurement by using the **RECALL** key or press **START** for starting a measurement. If measured, the values are automatically stored.

You are prompted to accept the recalled or measured values as a part of the averaged result. Press **ENTER** (alternatively **STORE**) to accept or **EXIT** (alternatively **DEL**) if you don't want to accept. You may repeat the loading of data to obtain the averaged results from more measurements. The number of measurements that has been accepted for the averaging is displayed by a number  $N$ . Press the **TBL** key to display the averaged levels.

Results		Criteria	
1/3-oct	$L_n$		$L_n$
200Hz	44.1	$C_T$	-14.0
250Hz	43.0	$C_T, 50-2500$	-14.0
315Hz	42.6		
400Hz	46.6		
500Hz	49.7		
630Hz	52.3		
800Hz	62.1		
1.0kHz	60.0		
1.25kHz	59.3		
Watd	69.0	Watd	69.0

The averaged level  $L$  is obtained according to the following formula where  $L_k$  is the result from each of the  $N$  measurements:

$$L = 10 \lg \left\{ \frac{1}{N} \sum_{k=1}^N 10^{L_k/10} \right\} \text{ dB}$$

### Background noise

The average background noise level,  $L_b$ , is obtained in a similar way.

Entering values for the background noise level is optional. If the level in the receiving room is more than 10 dB above the level of the background noise, no corrections will be made and the final result will be independent of having a background level or not. However, if the difference between the averaged level in the receiving room and the background noise is between 6 dB and 10 dB, a corrected level for the receiving room,  $L_{2C}$ , will be used in the calculation as described in ISO 140-7.

$$L_{2C} = 10 \lg \left\{ 10^{L_2/10} - 10^{L_b/10} \right\} \text{ dB}$$

The correction is limited to maximum 1,3 dB corresponding to a measured level in the receiving room 6 dB above the background level.

### Reverberation time

The acoustic losses of the receiving room used in the calculation may be obtained by measuring the reverberation time or by recalling earlier measured values. See the paragraph describing measurement of reverberation time. If the optional noise generator is installed it may be used for the excitation, otherwise impulse method has to be used. To start a measurement, press **START** when the field cursor is in the field for reverberation time marked "T". After the measurement you may inspect the resulting reverberation table by pressing the **TBL** key.

### Display of results

When the required information has been entered, the cursor will automatically be placed in the field for calculation of the final result. If you are satisfied with the entered values press **ENTER**, or if you want to make any correction, move the field cursor to the required field and enter the corrected values or press **DEL** to clear averaged values.

When you move the field cursor to the field "Results" and press **ENTER**, the following functions are calculated for each of the one third octaves-bands 50 Hz to 5000 Hz:

- The normalised impact sound pressure level  $L_n$
- The standardised impact sound pressure level  $L_{nT}$
- The averaged room level  $L$  corrected for background noise.
- The reverberation time  $T$

For the values  $L_n$  and  $L_{nT}$ , a frequency weighted value according to ISO 717-2 is also calculated. Pressing the **FUNC** key repeatedly will display the different functions. The weighted values are all rounded to the closest whole dB. The **TBL** key switches between graphical and tabular representation of the results.

If you want to go back to the menu for calculation, press **ENTER**.

Press the **MODE** button if you want to return to normal mode of operation.

### Store and recall

You may store the result by pressing **STORE**. The file is automatically designated with the next free file number succeeded with the letter "B" indicating building acoustics.

It is possible to save individual measurement files additionally to the overall building acoustic file. This feature is selected if the storage mode is set to "AUTO" in the SETUP menu.

### Partly re-use of previous measurements

When making several sound insulation tests where either the source or receiving room is used in both tests, it is convenient to re-use the averaged source level and/or the averaged reverberation time from the first measurement. By moving the cursor to either  $L_1$ ,  $L_2$ , T or  $L_b$  before pressing the **DEL** key the corrected averaged levels from the first measurement may be deleted by confirming the delete process. Thereafter the new measurements for the second insulation test are repeated for the receiving room levels or reverberation times.

Alternatively, each measurement at level or reverberation may be stored individually for later re-use by the RECALL feature. This is particularly useful for re-use of reverberation time measurements for both airborne and impact insulation using the same receiving room.

## Facade insulation

### General

The facade insulation may be measured using the modes for airborne sound insulation – the outdoor will then act as the source room. See ISO10052 and ISO 140-5 as appropriate for further details regarding requirements for the noise generating equipment and the selection of microphone positions.

Use of traffic noise for facade measurement is not covered in this description, as this requires simultaneous measurement in- and outdoor. However, this can be achieved by using two Nor140 sound level meters or a dual channel system such as the Nor121. Please contact your local Norsonic office for further information on such systems.

### Terms and definitions

The following terms are used in the display:

- $L_1$  sound pressure level 2 m in front of the facade [dB]. The term is designated  $L_{1,2m}$  in ISO 10052 and ISO 140-5.
- $L_2$  average sound pressure level in the receiving room [dB]
- $T$  reverberation time in the receiving room [s]
- $T_0$  reference reverberation time equal to 0,5 [s]
- $k$  reverberation index [dB]
- $D_{nT}$  standardised facade level difference [dB]. The term is designated  $D_{2m,nT}$  in ISO 10052 and ISO 140-5.
- $D_n$  normalised facade level difference [dB]. The term is designated  $D_{2m,n}$  in ISO 10052 and ISO 140-5.

$V$  volume of the receiving room [m<sup>3</sup>]

$A_0$  reference absorption area equal to 10 m<sup>2</sup>.



**Note** that you have to be in the menu for entering values before you are able to select another mode.

The relations between the quantities are given by the following equations:

### Sound excitation for facade measurement

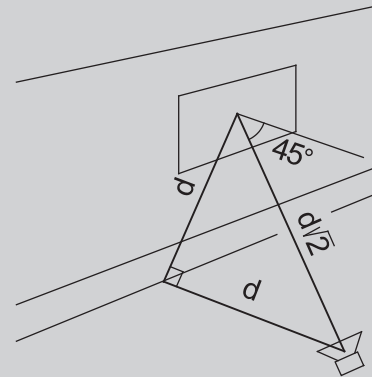

$$k = 10 \cdot \lg \left( \frac{T}{T_0} \right)$$

$$D_{nT} = L_1 - L_2 + k$$

$$D_n = L_1 - L_2 + k + 10 \cdot \lg \left( \frac{A_0 T_0}{0,16 \frac{m}{s} \cdot V} \right)$$



The values are calculated for each octave band. For  $D_{nT}$  and  $D_n$ , a single-number value is also calculated. The value corresponds to the 500 Hz value for the reference curve after shifted it in accordance with the method specified in ISO 717-1 for octave-band levels. The reference curve is shifted in one-dB steps until the unfavourable deviations between the octave-band results and the reference curve is as large as possible, but not more than 10 dB for octave bands or 32 dB for one-third octave bands.

### Noise excitation

The applied method requires broadband noise to be used for the excitation. The noise may be generated by the instrument if option 10, Noise generator, is installed. Sometimes it will be convenient not to have a cable between the instrument and the loudspeaker for the excitation. This may be achieved by using a radio-transmitter for the noise signal (contact Norsonic for more information) or to use a power amplifier with an internal noise generator such as the Nor280. Another alternative is to play a music-CD with recorded noise. Norsonic can supply a CD with the required excitation signal (Nor1033)

#### The menu for airborne sound insulation is also used for facade measurements

```
Airborne
V: 453.0 m² C
S: 5.6 m² C
L1:
L2:
T: E
Calc result

BRWG #
```

Normally the loudspeaker is placed on the ground in a position, which makes the angle between the normal to the facade and the sound incidence close to  $45^\circ$ . The distance from the loudspeaker to the centre of the test specimen shall be at least 7m. This may be obtained as shown on the adjacent figure if  $d$  is at least 5m.

### Measurement of sound level

The level may be measured in the normal mode of operation and stored for later processing, or the measurement may be started from the calculation menu when the result is required for the calculation. Then the measurement time has to be set up beforehand.

The source level shall be measured 2m in front of the facade, outside at the centre of the façade element. This level is designated  $L_1$ .

As stated in the standard, the spatial average of the sound level in the receiving room is required. See measurement of airborne sound insulation between rooms for further information.

#### Estimating the correction for the acoustic absorption

```
Estimate k:
Room type:
Furnished:
Kitchen
Bathroom
Other
Unfurnish.

BRWG
```

### Measurement of reverberation time

See measurement of airborne sound insulation between rooms for further information.

### Calculating the result

See measurement of airborne sound insulation between rooms for further information about calculating the results.

### Service equipment sound pressure levels – Survey method

See ISO10052 as this specifies how to measure service equipment sound pressure level. Option 11 has no special facility for this measurement. However, the service equipment sound pressure level may be measured in the normal mode of operation and the values specified in the standard may be calculated.

The standard specifies how the sound level in a corner position and in the reverberant field is averaged. The first level shall be weighted with 1/3 and the second level with 2/3. For equivalent levels,  $L_{Aeq}$  and  $L_{Ceq}$ , this may be achieved by selecting a measurement duration corresponding to the required measurement time for the corner position. Make the measurement by pressing **START**. Thereafter, move the sound level meter to the position in the reverberant field and press **PAUSE/CONT** for prolonging the measurement period. When the measurement is ended, press **PAUSE/CONT** a second time. The result will then have the required spatial weighting (1/3 – 2/3).

## Remote operation from a PC

Remote operation of the Building Acoustics features is possible for the Nor140 in combination with the NorBuild/CtrlBuild software package Nor1028. Option 11 then requires all the options 1, 3, 9 and 10 to be installed in the Nor140 unit.

Option 11 in combination with the other required options, includes all required remote commands for making building acoustic level or reverberation time measurements with the external CtrlBuild package. Option 11 also extends the internal noise generator (option 10) to include band-pass filtered noise in addition to white and pink noise. Further description of this option is given in the instructions for the CtrlBuild package.

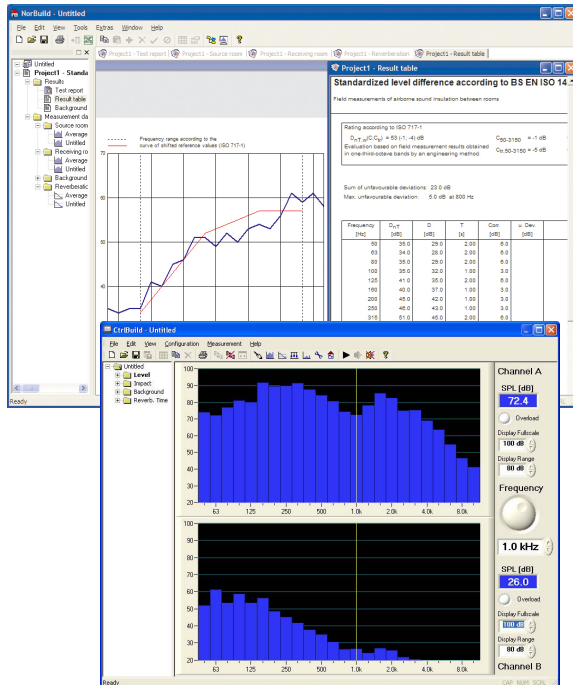

## Swept-Sine measurement technique

Swept-Sine measurement technique may be used for the measurement of the airborne sound insulation levels or for the reverberation time in accordance with the methods described in the ISO 18233 standard. The Nor140 instrument equipped with Option 12, Swept-Sine measurements, is able to perform this when controlled remotely from a PC in combination with the NorBuild/CtrlBuild software package Nor1028. Option 12 requires all the options 1, 3, 9, 10 and 11 to be installed in the Nor140 unit.

### Swept-Sine measurement of sound level

Upon connecting the Nor140 to the PC running the NorBuild software package with the CtrlBuild remote feature, the selection of Swept-Sine technique is made in the Measurement Mode menu of the software. Click on the point for "Level Swept-Sine".

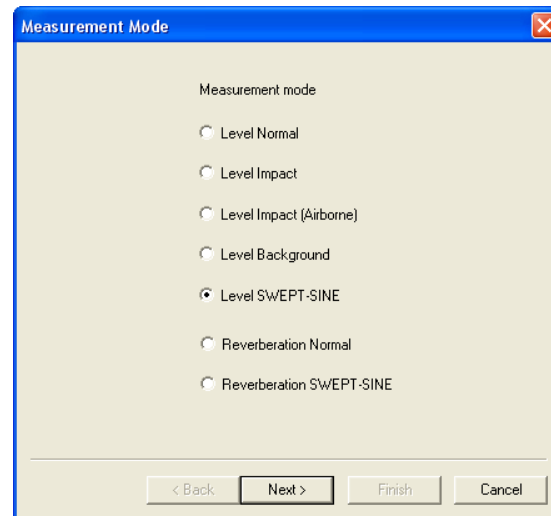

The different choices for the actual Swept-Sine level measurement are then displayed in the Measurement Setup menu.

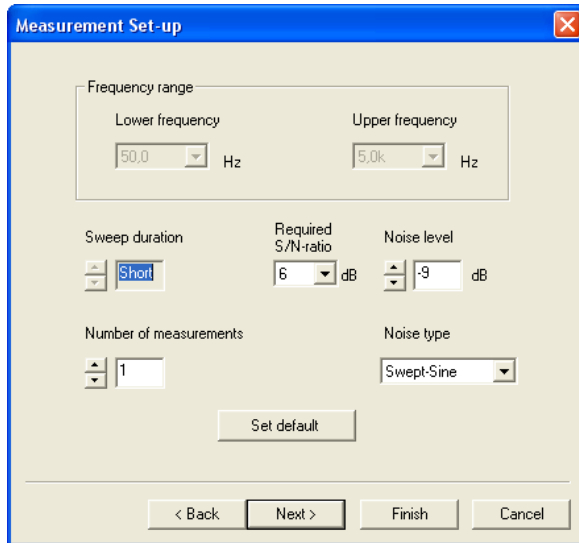

In the Measurement menu, there are two settings that differ from the normal operation of the NorBuild software package.

“Sweep duration” is used for selecting the speed of the sinus sweep used in the measurement. This can be set to “Short”, “Medium” or “Long” which makes the duration lasting approx. 1, 5 or 11 minutes respectively. The longer duration, the better S/N ratio is achieved.

“Required S/N-ratio” is setting the acceptance ratio for the measured results. Should any frequency band not give the required S/N-ratio, the value will be shown with a “?” in the result table.

The other settings are described in the instruction manual delivered with the NorBuild software package.

### Swept-Sine measurement of reverberation time

Click on the point for “Reverberation Swept-Sine” in the Measurement Mode menu, and follow the same selection possibilities as described above for the level swept-sine measurements.

# Speech Intelligibility by STIPA

## Introduction – What is STIPA

### Speech transmission index – STI

The speech transmission index, STI, has shown to be a valuable tool for objective rating the speech intelligibility. From its first presentation in *Acustica* in 1971 the method has been refined and developed for various applications. The International Electrotechnical Commission, IEC, has launched the third revision of the International Standard specifying the method for calculating the index as IEC 60268-16. Essential for this development was the work carried out at TNO-Human Factors in the Netherlands, and in particular the pioneers Tammo Houtgast and Herman Steeneken.

The STI-methods can be used to compare speech transmission quality at various positions and under various conditions within the same listening space; in particular it is useful for assessing the effect of changes in acoustic properties. This includes effects from the presence of an audience or of changes in a sound system. The methods are also able to predict the absolute rating of the speech transmission quality with respect to intelligibility when comparing different listening spaces under similar conditions or assessing a speech communication channel.

### Development of STI

The basis for the STI-index is that the intelligibility of speech is largely based on the slow modulation of the strength of the sound pressure signal that acts as a carrier. In the STI-method, the carrier is a stationary gaussian noise signal divided in seven bands in octave steps ranging from 125 Hz to 8 kHz. The bandwidth of each band is one-half octave. Each of the bands is modulated with one of 14 modulation frequencies. The modulation frequencies are selected in one-third octave steps from 0,63 Hz to 12,5 Hz. This gives in total 98 combinations.

In the STI-context, the square of the sound pressure is called intensity. The intensity is the quantity being modulated. A small loudspeaker playing the modulated excitation signal, acts as a talker.

The sound in the listener position is received by a microphone. The level and the degree of modulation in each octave band is used to determine the speech transmission index. Noise and reverberation in the room will reduce the observed degree of modulation. The method also considers the effect of the most common types of distortions such as harmonic distortion and intermodulation. However, other forms of non-linearity, like frequency shifts and frequency multiplications, are not treated effectively.

In order to fully take care of the effects of non-linearity, it is important that the basic signal being modulated is a noise signal with a high crest-factor, a spectral distribution similar to the long-term speech spectrum, and that the main modulation frequency is selected one by one. The measurement of the full STI therefore has to be performed as a sequence of measurements. If each of the 98 combinations is measured for 10 seconds, the total measurement time will be about a quarter of an hour. The need for such a long measurement time in order to obtain the STI-value in one position of a room limits the applicability of the full STI-method.

The STI-method may be modified in different ways to reduce the time needed for the measurement. If the system to be measured is regarded as linear, then a number of solutions exist. The excitation signal may be modulated with all modulation frequencies simultaneously and the components may be separated after reception by the use of filters or Fourier analysis. A more common method is to calculate the complex modulation transfer function from the impulse response of the room.

If the impulse response can be regarded as a well-behaved room response with an exponential decaying envelope characterised by the reverberation time, the modulation transfer function at frequency,  $F$ , may be calculated directly from the value of the reverberation time,  $T$ , and the effective signal-to-noise ratio  $S/N$  in dB. A simplified formula, not taking the effects of masking and the threshold of hearing into consideration, indicated the following relationship:

$$m(F) = \frac{1}{\sqrt{1 + \left(2\pi F \frac{T}{13,8}\right)^2}} \cdot \frac{1}{1 + 10^{(-S/N)/10}}$$

As seen from this formula, a limited signal-to-noise ratio reduces the modulation transfer function for all frequencies. A long reverberation time reduces the modulation most for the highest modulation frequencies.

The STI-value is a weighted average of the different modulation indexes. The last revision of the method (IEC-standard) also considers masking effects and the absolute threshold of hearing.

### **RASTI and STIPA**

In order to simplify the direct measurement, the RASTI-method (Room Acoustic Speech Transmission Index) was developed at TNO in 1979. Different instruments were developed for the measurement according to this standard. A typical measurement time was 10 to 15 seconds. The RASTI method only considers two octave bands 500 Hz and 2 kHz.

Due to the simplicity in use, the RASTI-instruments were used also for applications beyond the main design goal – room acoustics. The RASTI-value is often used for assessing the quality of public address systems, but comparisons with subjective measurements have shown that the deterioration of speech intelligibility is not handled correctly if the PA-system is strongly non-linear or suffers from limited bandwidth.

In order to improve the accuracy in the intelligibility assessment, the STIPA-method was developed. It handles effects due to reverberation in the room and distortions commonly found in public address systems. It also performs well for room acoustics and can therefore in nearly all cases replace the RASTI-method and deliver results more closely to the values obtained by the full STI-method. The measurement time for a STIPA-measurement is similar to the RASTI-method: 10 – 15 sec.

The STIPA method uses a higher degree of modulation for each test frequency. It will thus be more robust for interference from non-stationary background noise. See figure below for a comparison between the methods.

### How is STIPA measured

The instrument option comes complete with a CD containing the excitation signal. The excitation is played continuously through a loudspeaker and this act as a talker.

For a STI measurement, all carrier frequency bands are modulated with all modulation frequencies – in total 98 modulation indices. For RASTI, two carrier frequencies are used giving 9 modulation indices. For STIPA, 12 modulation indices are measured from the complete range of carrier frequencies

		Carrier frequency [Hz]						
		125	250	500	1k	2k	4k	8k
Modulation frequency [Hz]	0,63							
	0,8							
	1							
	1,25							
	1,6							
	2							
	2,5							
	3,15							
	4							
	5							
	6,3							
	8							
	10							
12,5								

**STI**

		Carrier frequency [Hz]						
		125	250	500	1k	2k	4k	8k
Modulation frequency [Hz]	0,63							
	0,8							
	1							
	1,25							
	1,6							
	2							
	2,5							
	3,15							
	4							
	5							
	6,3							
	8							
	10							
12,5								

**RASTI**

		Carrier frequency [Hz]						
		125	250	500	1k	2k	4k	8k
Modulation frequency [Hz]	0,63							
	0,8							
	1							
	1,25							
	1,6							
	2							
	2,5							
	3,15							
	4							
	5							
	6,3							
	8							
	10							
12,5								

**STIPA**

The battery operated Nor140 sound level meter is placed in the position in the room where you want the speech intelligibility to be judged. About 15 seconds after the start of measurement, the STI-value will be indicated on the screen of the instrument. No cable is needed between the excitation and the instrument.

## **CIS**

The instrument will use the measured STI value and also present the speech intelligibility in an alternative scale called “ Common Intelligibility Scale” abbreviated CIS. This scale is according to the definition in IEC 60849 (1998-02) Sound systems for emergency purposes. It is a non-linear relation between the STI and CIS value although both use 1 to indicate the best intelligibility and 0 for the poorest.

## **Units included in delivery**

### **Software option for Nor140**

The STIPA calculation program is designated as option no 13 on the Nor140. The option may be activated when the instrument is first delivered or installed on the sound level meter at a latter date. Please contact your local Norsonic dealer or the factory if you want your instrument upgraded with this option.

The STIPA-option requires the following additional option to be installed in the sound level meter:

- Option 1: 1/1-octave real-time filters in the frequency range 8-16.000Hz

## **CD for excitation**

The CD type Nor1034, included with the STIPA-option, contains two tracks: Track 1 and 2.

- Track 1: 1 kHz sinusoidal signal.  
Duration: 2 minutes
- Track 2: STIPA excitation signal, male speech.  
Duration: 70 minutes

Both signals have the same A-weighted level. Track 1 may therefore be used for test or calibration purposes – although the noise signal is recommended.

The STIPA excitation signal consists of bands of random noise each modulated with two frequencies. See IEC 60268-16 for further details. Note that if a loudspeaker is used for excitation, the loudspeaker's frequency response may change the spectrum of the excitation. The sound level meter may be used to verify or adjust the spectrum. For an excitation signal with A-weighted level  $L_x$ , the various octave bands should have the levels shown in the table on the right.:

## **CD with Excel sheet**

The CD contains two Excel work-books to be used with a PC:

- **STIPA-Calc** - Allows correction of the STIPA result for a virtual background noise.
- **STI-Calc** - A sheet for estimating the STI-value based on the speech level, background-noise level and the reverberation time



Octave band levels for male speech signal of A-weighted level $L_x$						
125 Hz	250 Hz	500 Hz	1 kHz	2 kHz	4 kHz	8 kHz
$L_x + 2,9\text{dB}$	$L_x + 2,9\text{dB}$	$L_x - 0,8\text{dB}$	$L_x - 6,8\text{dB}$	$L_x - 12,8\text{dB}$	$L_x - 18,8\text{dB}$	$L_x - 24,8\text{dB}$

Octave band levels for male speech signal of A-weighted level 66 dB						
125 Hz	250 Hz	500 Hz	1 kHz	2 kHz	4 kHz	8 kHz
68,9 dB	68,9 dB	65,2 dB	59,2 dB	53,2 dB	47,2 dB	41,2 dB

### Not included: CD-player and loudspeaker

A CD-player and loudspeaker for the excitation is *not included* in option 13. If you need advice for selecting suitable devices, please contact your local Norsonic representative.

Norsonic can deliver a commercially available small radio with rechargeable battery: Tivoli Audio PAL. It comes with a jack-socket for the excitation signal from the CD-player. When ordered through Norsonic, you will also receive a mounting bracket for mounting the radio on

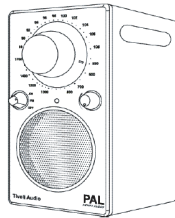

a tripod. The diameter of the loudspeaker is about 6 cm and the frequency response is fairly flat from 100 Hz to above 10 kHz.

It has been reported that the selection of the CD player may influence the measurement. We therefore recommend testing new equipment before you start the normal measurement tasks. If you supply the excitation signal electrically to the sound level meter (BNC-Lemo adaptor or cable available), or measure close to the loudspeaker, you should obtain excellent speech intelligibility ratings.

## Measurement overview

### General instrument description

The figure below shows a typical set-up for a STIPA measurement. The sound source, normally a small loudspeaker is acting as a talker. The loudspeaker should be placed in the normal position for a talker, either using or not using a public address system as required. The level should correspond to the normal level for speech.

The signal to the loudspeaker is obtained by playing the supplied audio-CD (Nor1034) with the recorded excitation signal.

Place the Nor140 sound level meter, with the STIPA option installed, in the place where you want the speech intelligibility to be measured. Press **MODE** and select the STIPA-mode. Press the **START** button. After about 15 seconds the estimated STI-value and the corresponding CIS value is indicated on the screen.

### Set-up for STIPA-measurement



#### Selecting a loudspeaker for the excitation

Most applications of the STIPA-method require a loudspeaker to act as a talker.

In this case, the directivity of the loudspeaker should be close to the directivity for a real human speaker as speech intelligibility depends upon the directivity of the source; therefore, a mouth simulator having similar directivity characteristics to those of the human head/mouth should be used for the highest accuracy when assessing the intelligibility of un-amplified talkers. Further, the frequency response between 100 Hz and 10 kHz should be flat. The loudspeaker should be a single element design or using coaxial element so the acoustical centre is well defined.

IEC 60268-16 recommend using a loudspeaker with a cone diameter of maximum 100 mm and refers to ITU-T Recommendation P.51 describing an artificial mouth. A sound source according to this specification is available from different manufacturers, with a typical example being the GRAS-44AA.

When speech is relayed through a sound system, a simulator is not normally required unless a close talking or noise-cancelling microphone is involved.

#### Loudspeaker or electrical excitation

Most applications require that the excitation is performed using a small loudspeaker acting as a human talker. However, some applications, such as testing public address or voice-alarm systems, are more conveniently tested with the electrical signal from the CD player fed directly into the system to be tested.

In a similar way, some applications related to test of transmission channels require an electrical signal as the input to the sound level meter for analysis. For this application, the microphone preamplifier may be substituted with a cable to the input socket of the sound level meter.



**NOTE!** For this description, a measurement set-up with acoustic excitation and detection using the normal measurement microphone is assumed!

## Performing a measurement

### Set-up

Set the sound source (artificial mouth or suitable test loudspeaker) in the normal position for the speaker. If a sound system is being used, place the sound source on the axis of the appropriate microphone at the normal speaking distance (measured from the lip-circle for the artificial mouth or acoustic centre of the loudspeaker) and direct it in the normal speaking direction. Connect an appropriate CD-player to the sound source.

### Set the speech level

Switch on the sound level meter and ensure that it is properly calibrated. Play track 2 with the STIPA excitation signal and adjust the level to the required speech level, normally 60 dB at 1 m from the sound source. (66 dB at 0,5 m) Alternatively, track 1 with the sine excitation may be used – both should produce about the same A-weighted level.

After setting the speech level, play the STIPA excitation signal on Track 2 during the measurement. (70 minutes).

The standard IEC 60268-16 recommends that the excitation spectrum is correct within  $\pm 1$  dB for the applicable frequency range.

### Select the STI-mode

The STI mode is one of the modes of operation for the Nor140 instrument. By selecting this mode, the instrument will automatically be configured for STI-measurements. For selection, press **MODE** after

switching the instrument on, and select STI by pressing the numeric button **5**. After the selection, the instrument is ready for a STI-measurement. A "\$"-sign in the upper left corner of the display indicates the STI-mode of operation.

The instrument screen will show the level versus frequency display. Time constant will be F. The cursor will be positioned for indication of the A-weighted level.

### Making a measurement

Start a measurement by pressing the **START** button. The measurement lasts for 13 seconds. During the measurement the level versus frequency display will be shown together with an indicator of an ongoing (running) measurement. After the measurement is ended, the main STI display will be shown after a short calculation period.

For the first measurement after the STI-mode is selected, the Noise correction will be selected off and the cursor will be placed above the "Off" field.

The measured result will be indicated as a STI-value together with an assessment of the intelligibility. The STI-value and the assessment are according to the

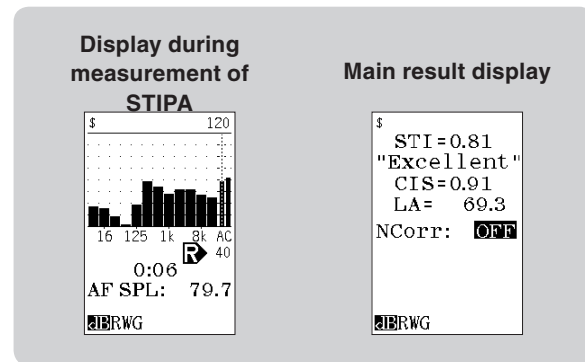

**Display of speech level octave-band spectrum**

\$	
0:13	
1/2-oct	Lea:
125Hz	75.6
250Hz	73.8
500Hz	66.2
1.0kHz	62.1
2.0kHz	57.3
4.0kHz	42.3
8.0kHz	50.0
16.0kHz	31.5
A-netw.	69.3
BRWG	

**Two modulation indices are measured for each octave-band**

\$	
1/2-oct	
250Hz	m
1	0.90
5	0.74
500Hz	
0.63	0.93
3.15	0.92
1.0kHz	
2	0.95
10	0.78
BRWG	

Modulation index for 500 Hz octave-band, modulated with 3,15 Hz.

STIPA-procedure in IEC 60268-16 (2003-05) for male voice. The corresponding CIS-value (Common Intelligibility Scale) according to IEC 60849 (1998-02) is also indicated. The mean A-weighted speech level is indicated in dB relative to 20µPa.

If the measured value is detected as unreliable, a question mark is placed behind the indicated value for STI and CIS.

The speech level for each octave may be displayed by pressing **TBL**.

A second press on the **TBL** button displays the modulation indexes for each of the STIPA-octaves. The combined value for the double-octave 125 Hz and 250 Hz is listed as 250 Hz.

The number below each octave frequency is the modulation frequency in Hz. The corresponding uncorrected modulation index is displayed to the right. Press the key **TBL** again to display the highest frequencies. Press the **TBL** button once more for return to the main display.



**NOTE!** We recommend that from time to time you test your CD-player, loudspeaker and sound level meter under close to ideal conditions. Such a situation exists just in front of the loudspeaker placed in a large room when the background noise is considerably lower than the excitation signal. Adjust for a level between 60 and 70 dB. In this case, you should obtain a STI-value close to one.

**Store and recall the result**

After the measurement is performed, the results may be stored in the non-volatile memory of the instrument or on the SD-card; this is done by pressing the button **STORE**. Alternatively, the instrument may be set up to store automatically after each measurement, see the general instructional manual for Nor140 for information about the file structure. A stored result may later be recalled.

**When stored, a file number is shown in the upper line, is automatically assigned to the measurement**

```

$
  STI=0.81
  "Excellent"
  CIS=0.91
  LA= 69.3
  NCorr: ON
  STI=0.81
  "Excellent"
  CIS=0.91
  #BRWG
    
```

### Correcting for background and occupancy noise

The STIPA method considers the effect of the actual background noise when the intelligibility is assessed. However, in some cases we want to find out what the intelligibility would have been if we had a certain background noise. A typical application will be to assess

#### Edition of the background noise level

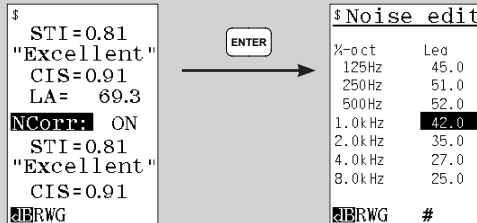

the intelligibility in an auditorium with audience when the auditorium was measured without. For such applications, the optional noise correction may be used.

Measure the STI-value as described above. Place the cursor above the field “Off” in “Noise correction: Off”, and press **INC** or **DEC** button to toggle the value to “On”. The results will be recalculated to account for the specified background noise.

The result is corrected for a stored background noise spectrum. If you want to edit the values, move the field cursor to the field “NCorr:” and press **ENTER**. The field cursor is automatically placed at the lowest octave-band 125 Hz. Write in the required level for each octave by using the numeric keyboard. An “#E” at the bottom of the display indicates numeric keyboard (second function) and that each entry has to be terminated by pressing **ENTER**. Move the cursor field to the next frequency by using the cursor buttons below the display and enter the corresponding level. For terminating the edition and returning to the main menu, press an additional **ENTER**. The noise corrected values are automatically recalculated.

The correction is done according to the following equation:

$$m_{c,k,f} = m_{k,f} \frac{I_k}{I_k + I_{rs_k} + I_{no_k} + I_{am_k}}$$

where

$m_{c,k,f}$  is the corrected modulation transfer function for octave band number  $k$  and modulation frequency  $f$ .

- $m_{k,f}$  is the measured modulation transfer function (as displayed).
- $I_k$  is the measured “intensity” in octave band number  $k$
- $I_{RS_k}$  is the “intensity” in octave band number  $k$  related to the threshold of hearing
- $I_{no_k}$  is the optional “intensity in octave band number  $k$  corresponding to a specified background noise level. If not used this value is zero.
- $I_{am_k}$  is an “intensity” in octave band number  $k$  used to mimic the masking effect in the auditory organ. The value is a function of the level in the adjacent lower octave band.

An alternative to keying in the levels for the background noise is to use values from a previously stored measurement. The measured levels must have been made in 1/1- or 1/3-octave bands. Press **RECALL** while the table for the background noise is displayed. Select the requested file from stored results and press **ENTER** to read in the data. Values measured in 1/3-octave bands are recalculated to 1/1-octave values.



**NOTE!** You may obtain the averaged level from different measurement positions by making a normal measurement in the first position, then move to the next and press **CONT** for prolonging the measurement time!

## Real background noise

If a real background noise is present during the measurement, the effect of the noise will in most cases be treated as noise according to the STIPA-method and lower the STI-value. However, some noise signals may be interpreted as a STIPA excitation signal giving wrongly a modest STI value. The instrument is programmed to detect such situations and place a question mark adjacent to the indicated value. However, not all cases can be detected properly. To investigate such potential problems, we recommend making a measurement without an excitation signal. If this STI-value is low or considerably lower than the value measured with the excitation signal (preferably  $STI \leq 0,2$ ), the reading will have a high degree of reliability.

If the background noise can be switched off, it is possible to measure the response to the STIPA-excitation and noise level separately. The STI-value may be corrected for the background noise later – in the instrument or by applying the Excel-sheet “STIPA-calc” delivered with the instrument option. This will eliminate the interference between a spiky-noise signal and the STIPA-method.

## Precision of the STIPA method

Because the test signal is band-limited random or pseudo-random noise, repetition of measurement does not normally produce identical results, even under conditions of steady interference. The results centre on a mean with a certain standard deviation. Typically, the value of the standard deviation is about 0,02 with stationary noise interference. With fluctuating noise (for example, a babble of voices), higher standard deviations may be found, possibly with a systematic error. This can be checked by carrying out a measurement in the absence of the excitation signal. This

should result in a residual STI value less than 0,20. An estimate of the standard deviation should be made by repeating measurements for at least a restricted set of conditions.

## Analysis and interpretation of the results

It is important to examine the modulation matrix to determine the reliability of the results.

As a rule, the modulation index in each octave-band should decrease with increasing modulation frequency. Constant or slightly reducing values in a column indicate the presence of noise. Large reductions indicate that reverberation is the main effect. Values that first reduce and then increase with increasing modulation frequency indicate the presence of periodic or strong reflections, which may produce an over-optimistic conclusion. It is recommended that if this effect is detected, it should be reported with the results and an estimated correction applied.

## Limitations of the STIPA method

The STIPA method should not be used for those public address systems that

- a) introduce frequency shifts or frequency multiplication;
- b) include vocoders (i.e. LPC, CELP, RELP, etc.);
- c) have a background noise that is impulsive;
- d) introduce strong non-linear distortion components.

If d) applies, or possibly applies, the full STI method should be used instead or used to verify the results obtained by the STIPA method.

## Using Excel for further calculations

An Excel workbook "STIPA-Calc" is delivered with the STIPA-option. The workbook allows you to correct your readings for different speech levels and levels of background noise similar to the corrections available in the instrument.

Recall the stored results from an earlier measurement. Press the button **TBL** to display the speech level and enter the levels into the cells for the speech level. Press **TBL** once more to obtain the modulation indices and bring the values into the appropriate cells. You may then enter values for the background noise and see how this will affect your reading.

The values from the STIPA-measurement may be transferred to the PC by using the USB or serial interface on the instrument. A transfer program like NorXfer may be used.

## STI-Calc

On the CD with STIPA-calc, you will also find a program called STI calc. This program may be used to estimate the STI-value based on information on the octave-band levels for speech and background noise and the reverberation of the room – also in octave bands. The applied formulas assume linearity and that the impulse response for the room is well behaved without significant echoes. The calculation should not be used as a replacement for a real measurement of the STI-value.

## Specifications

The STI-value is measured according to the requirements for STIPA method defined in:

*IEC 60268-16 (Ed.3.0 2003-05): Sound system equipment – Part 16: Objective rating of speech intelligibility by speech transmission index.*

The method specified in the International standard is extended with the option for background noise correction.

The CIS-value is calculated from the STI-value as specified in:

*IEC 60849 (Ed. 2.0 1998-02) Sound systems for emergency purposes.*



# FFT

## measurement mode

### Introduction

When the FFT option 14 is installed, the instrument may make a narrow-band frequency analysis of the input signal and calculate the auto spectrum. The signal is sampled with a sampling frequency of 24 kHz and a **F**ast **F**ourier **T**ransformation based on  $2^{14} = 16384$  samples is performed. This allows the signal to be analysed with a constant frequency resolution of 1.46 Hz. The signal strength may be displayed in logarithmic [dB] or linear units [engineering units EU].

### How to select the FFT-mode

To put the instrument in FFT-mode of operation, press the key **MODE** and select **6** for FFT. If you want to return to the normal mode of operation, you have to press the key **MODE** again and select **1** for Normal.

### Making a measurement

A measurement in FFT mode may be started as a normal level measurement by pressing the **START** button. If Option 16 – extended trigger is installed, the same trigger possibilities apply as in normal mode of opera-

tion: the measurement may be started at a certain time of the day or if the level goes above a certain level. The level triggering is based on the normal weighting network or fractional-octave band level.

The measurement duration may be set as time or as a number of single measurements used to obtain an averaged auto-spectrum. See figure overleaf. NA indicates the number of single measurements in the averaged value. The averaged result is continuously updated on the screen during the measurement. The measurement may be stopped before the selected number of periods is reached by pressing **STOP**. The duration of each single FFT-period is 0,685 s.

The FFT-mode is selected in the mode menu.

```
MODE:
1: Normal
2: Rev.
3: Power
4: BuildAc.
5: STIPA
6: FFT
```

```
URWGS #
```

During and after a measurement, the result is displayed as shown on the figure. The upper and lower values of the displayed frequency axis are shown just below the diagram. The frequency range may be zoomed or compressed. The compression factor are adjusted in a power of 2 sequence by cursors keys ▲ (Compress) and ▼ (Zoom) respectively. (1x, 2x, 4x... etc.)

The cursors are moved along the frequency axis by the cursor keys ◀ and ▶. If the cursor is in the left or right extreme position, the spectrum will scroll about 1/3 of the displayed frequency range.

The cursor keys ◀ and ▶ moves the cursor to the extreme left-hand or right-hand position, respectively. A further operation of these keys will scroll the display along the frequency axis.

The displayed level range may be scrolled by using the **INC** and **DEC** buttons as in normal mode of operation.

### Setting the measurement duration

<b>Meas.dur.:</b>	
Duration:	000:00:06
Resolution:	685 ms
NA:	10
N:	0
Mx:	340
FFT	#

## Calibration

The instrument has to be calibrated in the normal mode of operation. The readout may be in decibel or engineering units.

## Corrections

The correction for random response, windscreen and preamplifier gain also applies in FFT-mode of operation.

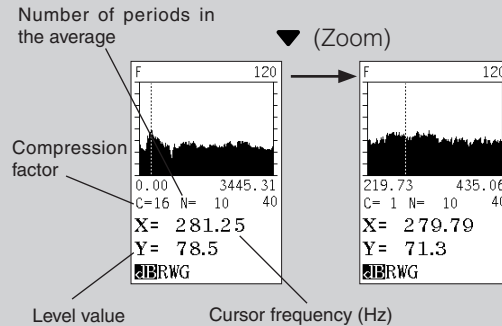

Move the cursor to obtain the digital value for the spectrum at one particular frequency. Use the field cursors ▲ and ▼ to change the compression factor.



If the display is compressed, more spectral lines are displayed as one line. The cursor value will show the maximum value for all the lines represented by the cursor position. In order to read the values for each spectral line, you have to zoom until the compression factor is one ( $C = 1$ )!

### Storing the result

The measured spectrum may be stored in the instrument and later retrieved or exported to a PC by using the NorXfer program. The storing is as simple as in the normal mode of operation. A file number is automatically generated. In the file list the file number is succeeded with the letter "f" indicating a FFT-result. The storing may be manual or automatic as in the normal mode of operation.

### Specification for FFT

Sampling frequency:	24 kHz
FFT size:	16384 samples (0.682666 sec)
Frequency lines:	8192 frequency lines 6553 will be available (after LP anti-aliasing filter)
Anti-aliasing filter:	Pass-band ripple: 0.03 dB Stop band attenuation: 100 dB
Frequency range:	0 ... 9600 Hz (-1 dB point)
Frequency resolution:	$\Delta f = 1/T = 1.46... \text{ Hz}$ (24000/2 <sup>14</sup> )
Window function:	Hanning
FFT function:	Auto spectrum
Spectrum unit:	dB and EU (Engineering units)
Averaging:	Linear power averaging
Number of averages:	1 to 1028571
Trigger:	Manual, External, Clock, Level above (Option)
Input source:	Microphone socket
Dynamic range:	120 dB, 80 dB displayed.
Zoom:	Display function ( $C = 1, 2, 4, 8, \dots 64$ )

# Measuring vibration using the Nor140

## Introduction

Most sound level meters and sound analysers can be used for vibration measurements, even if they do not provide absolute (linear) units in the display. To simplify the description, this chapter describes the use of the handheld sound level meter Nor140 for vibration measurement. However, the described principles also apply to other types of sound level meters.

Although several transducer principles are commercially available, this application note will deal with the accelerometer only, simply because it is the transducer type most commonly encountered when measuring vibration levels. As the name suggests, the accelerometer measures the acceleration it is exposed to and provides an output signal proportional to the instant acceleration.

The accelerometer normally consists of a seismic mass mechanically connected to the accelerometer base through a piezoelectric material. Piezoelectric materials have the property of producing electrical charge when bent and twisted (even shear forces will work here). Basically, a charge is generated. Depending of the type of transducer, this charge may be the output signal or the transducer includes an amplifier delivering an output signal with low impedance.

A popular type of transducers is the IEPE or CCP type. These are powered by a constant current through the signal cable and deliver an output voltage which is the sum of a constant voltage and an AC-voltage proportional to the acceleration.

## Accelerometer

Many types of acceleration sensitive sensors exist. For connection to Nor140 sound level meter the easiest is to apply an IEPE or CCP type. This type of transducers has low output impedance and may be supplied through a coaxial cable. Nor1270 (Sens. 10 mV/ms<sup>-2</sup>; 23 g) and Nor1271 (Sens. 1,0 mV/ms<sup>-2</sup>; 3,5 g) are recommended. Connect the accelero-meter through the BNC/Lemo cable Nor1438 and the BNC to microdot adaptor Nor1466. You also need a BNC-BNC female connector. See the figure below.

Alternatively, a charge sensitive accelerometer may be used and coupled to the normal microphone preamplifier Nor1209 through the adapter with BNC input Nor1447/2 and the BNC to microdot adaptor Nor1466. The voltage sensitivity will depend on the total capacitance of the cables and adaptors and the calibration procedure is thereby more complicated

than for the IEPE-type of accelerometers if a vibration calibrator is not at hand. Due to the high impedance of the signal from the transducer, the cables will also often be sensitive to vibration. However, charge sensitive accelerometers often have lower weight and may tolerate higher temperatures.

### IEPE-type

If you use an IEPE-type of accelerometer with a known sensitivity, it is easy to calculate the required sensitivity setting for the instrument. Just enter the sensitivity for the accelerometer in volt per unit as a level-sensitivity in dB.

Set-up for using an IEPE or CCP type of accelerometer connected to Nor140. Power to the accelerometer is supplied from the instrument by selecting IEPE in the instrument menu as preamplifier.



Set-up for using a charge-sensitive type of accelerometer connected to Nor140. The charge produced by the accelerometer generates a voltage proportional to the inverse of the capacitance loading the charge generator. The capacitance is the sum of the capacitance for the accelerometer and all cables connected to the transducer. The microphone preamplifier, normally Nor1209, has very high input impedance – typically 10 gigaohm and an input capacitance below 1 pF – and will not modify the loading impedance. The voltage representing the acceleration is transferred to the sound level meter through the preamplifier. Typical attenuation through the adapter Nor1447/2 and the preamplifier Nor1209 is 0,1 dB. Select the “Standard” preamplifier in the instrument set-up menu, but switch off the polarisation voltage.

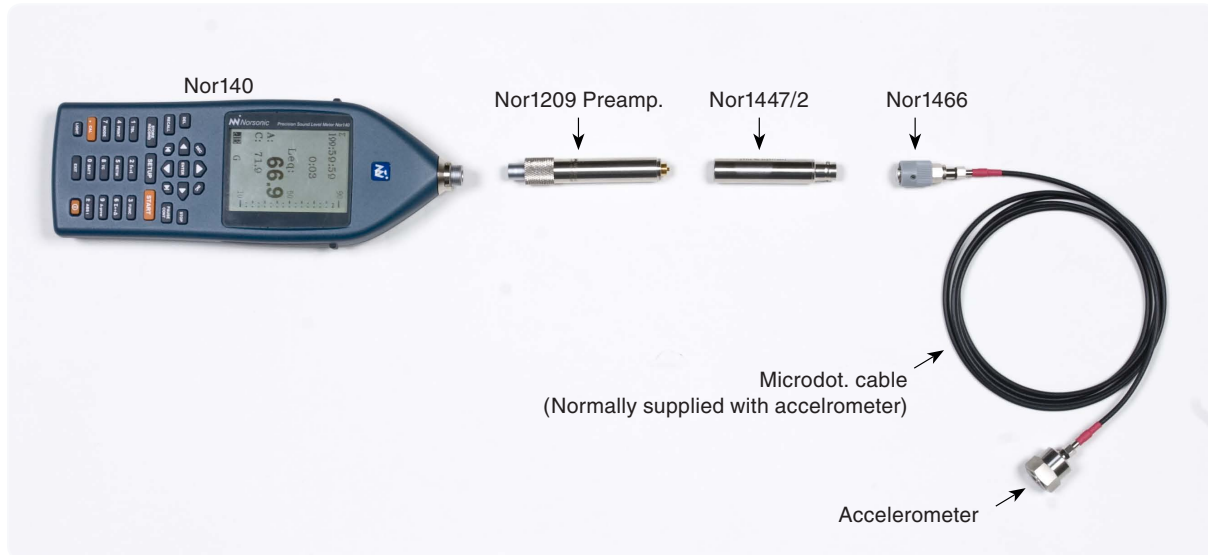

Example: Assume the sensitivity for the accelerometer is 2,5 mV/ms<sup>-2</sup>. The level-sensitivity is therefore:

$$L_s = 10 \lg \left\{ \frac{\left(0,0025 \frac{\text{V}}{\text{ms}^{-2}}\right)^2}{\left(1 \frac{\text{V}}{\text{ms}^{-2}}\right)^2} \right\} = -52,0 \text{ dB}$$

By entering this value as sensitivity in the calibration menu, the instrument is calibrated and the reading in engineering units will be given in ms<sup>-2</sup>. Remember to select IEPE as preamplifier and set the preamplifier correction to “Off”.

### Charge type

If you use a charge sensitive accelerometer, see picture on page 164, you need to know the capacitance of all cables and accessories in addition to the charge sensitivity and the capacitance of the accelerometer. The following example will show how to calculate the sensitivity.

The accelerometer is assumed to have the charge sensitivity  $3 \text{ pC/ms}^{-2}$  ( $\text{pC} = \text{pico-coulomb}$ ) and a capacitance of  $950 \text{ pF}$ . The capacitance of all cables and adaptors between the accelerometer and the preamplifier is measured to be  $230 \text{ pF}$ . The voltage sensitivity will be the charge sensitivity divided by the sum of the capacitances of the accelerometer and the cable with accessories:

$$\frac{3 \frac{\text{pC}}{\text{ms}^{-2}}}{950 \text{ pF} + 230 \text{ pF}} = 2,542 \cdot 10^{-3} \frac{\text{V}}{\text{ms}^{-2}}$$

The corresponding level sensitivity will be:

$$L_s = 10 \lg \left\{ \frac{\left(0,002542 \frac{\text{V}}{\text{ms}^{-2}}\right)^2}{\left(1 \frac{\text{V}}{\text{ms}^{-2}}\right)^2} \right\} = -51,9 \text{ dB}$$

Typical attenuation through the adapter Nor1447/2 and the preamplifier Nor1209 is  $0,1 \text{ dB}$ . Subtract this attenuation from the level sensitivity (E.g:  $-52,0 \text{ dB}$ ).

Remember to select "Standard" as preamplifier and set the preamplifier correction and polarization voltage to "OFF" in the set-up menu for the instrument.

### Velocity and displacement

Vibration is often measured as velocity or displacement. The velocity can be obtained from the acceleration by time integration of the signal. In a similar way displacement may be obtained by integrating the acceleration twice. No integration is performed in the sound level meter Nor140. However, if the vibration signal is sinusoidal with frequency  $f$ , an integration correspond to dividing the acceleration by the angular frequency  $\omega = 2\pi f$ . This may also be used for more complex signals analysed in 1/3-octave bands or analysed by the FFT-option. An example may illustrate how this is done.

Assume that the vibration level in the  $80 \text{ Hz}$  band (1/3-octave is assumed) is  $74 \text{ dB}$  or  $0,1 \text{ ms}^{-2}$ . The exact midband frequency for the  $80 \text{ Hz}$  filter is  $10^{1,9} = 79,43\dots \text{ Hz}$  (See ISO 8041). The vibration velocity is therefore:

$$\frac{0,1 \text{ ms}^{-2}}{2\pi \cdot 79,43 \text{ s}^{-1}} = 0,0002 \text{ ms}^{-1}$$

The corresponding vibration displacement is:

$$\frac{0,1 \text{ ms}^{-2}}{(2\pi \cdot 79,43 \text{ s}^{-1})^2} = 0,0000004 \text{ m} = 0,4 \mu\text{m}$$

### Calculation of frequency weighted acceleration

Different types of frequency weightings are in use for obtaining a single value for the vibration severity. The international standard ISO 8041 specify nine different frequency weightings related to human response to vibration. The different time-averaged weighted acceleration values may be calculated from the levels in the 1/3-octave bands.

If the acceleration in  $i^{\text{th}}$  frequency band is  $a_i$ , and  $w_i$  is the weighting factor for that band, the weighted acceleration,  $a_w$ , will be given by:

$$a_w = \left[ \sum_i (w_i a_i)^2 \right]^{1/2}$$

The values for  $w_i$  are found in ISO 8041 and depends on the selected weighting.



# Audiometer calibration

Audiometer calibration is made easily with a Nor140 sound level meter (software option; audiometer calibration and 1/3-octave frequency analysis is required).

Frequency, Level and Distortion is measured and presented after each single measurement.

To activate the audiometer calibration software in Nor140, press **SETUP > 1 > 9** Misc .par, choose **5** Audiometer and toggle audiometer calibration function ON/OFF with **INC/DEC** keys. Press **ENTER** repeatedly to confirm and leave menus.

Connect and calibrate Nor140 to an artificial ear, for example. Gras 43AA. Play the desired tone (frequency and level) of the audiometer connected to the artificial ear.

Press **START** on Nor140, measurement time is by default 2 sec but can be changed by the user. Nor140 presents after a single measurement, the precise frequency, level and distortion on the display. The measurement can be saved and exported to NorXfer PC software.



# Technical specifications

Unless stated otherwise, the specifications are for the complete sound level meter Nor140 equipped with microphone type Nor1225 and microphone preamplifier type Nor1209. Values are based on the sensitivity set to the nominal value for the microphone: -26.0 dB corresponding to 50 mV/Pa.

A microphone cable Nor1408 of length up to 20 m may be used between the microphone preamplifier and the instrument body without loss of performance. Longer cables may be used if maximum sound pressure level or frequency is reduced.

The definition of terms is based on IEC 61672-1 (2002-5): Electroacoustics - Sound level meters - Part 1: Specifications.

The options included in the basic instrument may vary. Please check with your local supplier for the latest information.

## Type of instrument

Sound level meter IEC 61672-1, class 1, group X measuring exponential time-weighted levels, integrating-averaging levels and sound exposure levels. If 1/1 octave-band or 1/3 octave-band filters are installed, the instrument complies with IEC 61260 class 1. The instrument also complies with the previous standards IEC 60651 type 1 and IEC 60804 type 1.

The instrument conforms to a number of national standards such as: DIN 45677 (1997), ANSI S1.4-1983, ANSI S1.4A-1985, Type 1 and ANSI S1.43-1997, Type 1. Bandpass filters conform to ANSI S1.11-2004, class 1.

## Analogue inputs

**Number of channels:** 1

**Input connector:** 7 pin LEMO connector for Norsonic microphone systems. (LEMO ECG.1B.307.CLL)

**Preamplifier:** Nor1209 (Normal) or IEPE-type by menu selection.

**Preamplifier Nor1209:**

**Preamplifier supply voltage:** ± 15 volt, max 16mA

**Polarisation voltage:** 0 V and 200 V, selectable.

**Maximum input signal:** ± 11 V peak

**Input impedance:** More than 100kohm, less than 650pF

**Preamplifier IEPE:**

**Supply current:** 3mA

**Supply voltage:** 24V

**Input impedance:** More than 100kohm, less than 650pF

**Measurement range:** 0.3  $\mu$ V to 7 V (RMS) in one range corresponding to -10dB to 137dB with a microphone sensitivity of 50mV/Pa. The maximum peak value  $\pm$ 10V corresponds to 140 dB.

With the optional extension permitting extended measurement range, peak values up to 150dB may be measured.

### Microphone input socket

#### Pin Function

- |          |                                                                                                                                                              |
|----------|--------------------------------------------------------------------------------------------------------------------------------------------------------------|
| <b>1</b> | Microphone system check                                                                                                                                      |
| <b>2</b> | GND – signal reference                                                                                                                                       |
| <b>3</b> | Polarisation voltage – selectable: 0 $\pm$ 1V, 200 $\pm$ 1V or adjustable 70 to 74V short-circuit current <1mA, impedance: 2 M $\Omega$                      |
| <b>4</b> | Signal input. Input impedance: min 0,6 M $\Omega$ , max 250 pF. When IEPE is selected in the setup, a constant current of 3 mA is supplied (25 volt source). |
| <b>5</b> | +15 $\pm$ 1V preamplifier supply voltage, max 3 mA (Connected to pin 6)                                                                                      |
| <b>6</b> | Connected to pin 5                                                                                                                                           |
| <b>7</b> | -15 $\pm$ 1V, preamp. supply voltage, max 3 mA<br>Housing is GND instrument casing.                                                                          |

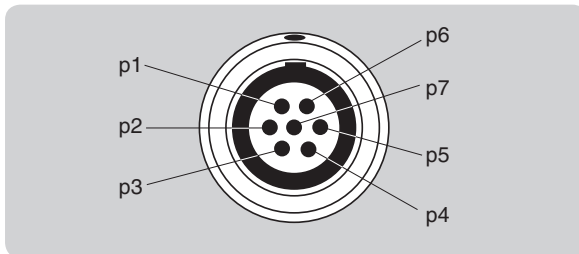

Highpass filter frequency response

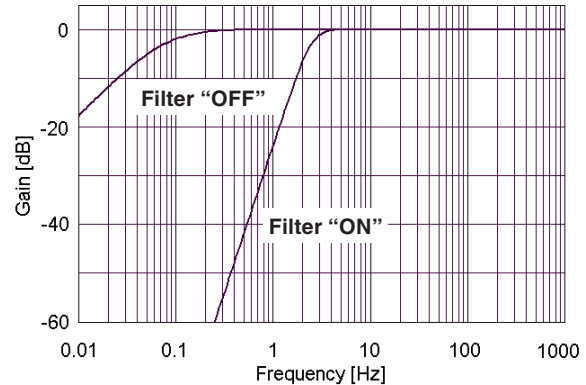

### Highpass filter

The input section is equipped with an analogue high-pass filter to reduce noise from wind or other sources with frequencies below the frequency range for measurements. The filter is switched on if the limited frequency range is selected (>6,3Hz). When this filter is "Off" the lower frequency is 0.4 Hz. This setting is in use when the optional octave or third octave filter is set to "W" (for wide), or when the second weighting network "Z-wide" is selected

**Filter type:** 3rd order HP filter (-3dB at 3,4Hz, Butterworth response)

### Analogue to digital conversion

The analogue input signal is converted to a digital signal by a multirange sigma-delta converter with an effective sampling frequency of 48 kHz. The anti-aliasing filter is a combination of an analogue and a digital filter.

## Frequency weightings

### Weighting networks

Simultaneous measurement of two weighting networks

- A and C-weighting or
- A- and Z-weighting

The Z-weighting network may either be set to Normal mode covering the frequency range from 6.3 Hz to 20 kHz, or to Wide mode where the low frequency range is extended down to 0.4 Hz. The -0.5dB points for the two versions of the Z-network are 10Hz and 1.6Hz respectively.

The 1/1 octave band or 1/3 octave band levels may be measured simultaneously with the weighting networks if appropriate options are installed.

In the rest of this specifications section **Z-normal** is assumed and selected if not **Z-wide** is clearly indicated.

### Filters

**1/1 octave filters:** 0,5 Hz – 16 kHz (wide frequency selection), or 8 Hz – 16 kHz (normal selection)

**1/3 octave filters:** 0,4 Hz – 20 kHz (wide frequency selection), or : 6,3 Hz – 20 kHz (normal selection).

**Filter type:** Class 1, digital IIR filters, base 10 system. According to IEC 61260). Use of octave or third octave filters require that appropriate options are installed

### Level detector

**Detector type:** Digital true root-mean-square (RMS) detection and peak detection, displayed resolution 0.1 dB which may optionally be increased to 0.01 dB for indicated levels in the range -9.99 to 99.99 dB. Using remote control commands levels with 1/100 dB may always be read out.

**Crest factor capability:** The crest factor is only limited by the capability to measure the peak-value of the signal.

### Time weightings and measured functions

Simultaneous measurement of the following functions:

- F-time-weighted sound pressure level, instantaneous
- Maximum F-time-weighted sound pressure level
- Minimum F-time-weighted sound pressure level
- S-time-weighted sound pressure level, instantaneous
- Maximum S-time-weighted sound pressure level
- Minimum S-time-weighted sound pressure level
- I-time-weighted sound pressure level, instantaneous
- Maximum I-time-weighted sound pressure level
- Minimum I-time-weighted sound pressure level
- Integrated-averaged sound pressure level
- Sound exposure level
- Peak sound level
- Exceeding level for F-time-weighted sound pressure level (cumulative distribution)

As an option, the sound level meter may also simultaneously measure:

- Integrated-averaged I-time-weighted sound pressure level
- I-time-weighted sound exposure level
- Taktmaximalpegel – DIN 45657, F time response, 5 seconds Takt.

## Level distribution

As an optional extension, the instrument may be fitted to calculate the exceeding level (cumulative level distribution) for the F time weighted level. The calculation is done for frequency weightings A and C or Z and for 1/1 octave or 1/3 octave filters (if present and used in a measurement).

**Class width:** 0.2 dB

**Number of classes:** 652 for levels between 10 dB above full scale (140 dB) and 120 dB below full scale (10 dB). The classes for the highest and lowest levels are extended to also include levels above and below, respectively.

**Sampling frequency for level:** 10 samples per second.

**Display resolution:** 0.1 dB based on interpolation.

## Indication range

The calibration of the instrument allows microphones with sensitivity in the range  $-84$  dB to  $+15.9$  dB relative to 1 volt/pascal to be applied. The corresponding display range for the indicated sound level is  $-50$  dB to  $+180$  dB.

## Self-noise levels

The self-noise is measured with the calibration set to  $-26.0$  dB corresponding to a microphone sensitivity of 50 mV/Pa. For voltage input, the level 0 dB then corresponds to  $1\mu\text{V}$ . Typical values for the self-noise are 5dB lower than the values stated. The noise levels are measured without light in the display. Please note that the octave and third octave filters require the options 1 and 3 respectively.

## Z-wide considerations

The Z-wide network requires several minutes to stabilize at a low level. The preamplifier between the microphone and the sound level meter is a very high impedance device and due to their construction they all have a noise spectrum with increased levels at lower frequencies. There may be relatively large variations in this noise level between the different samples of preamplifiers. The sensitivity to vibration will appear as higher than normal at low frequencies. This makes this network unsuited for real low level, low frequency measurements.

Noise measured with 18 pF microphone dummy and microphone preamplifier Nor1209, averaged over 30 s of measurement time:

### Spectral weighting functions:

A-weighted: 13 dB

C-weighted: 15 dB

Z-normal -weighted: 25 dB

Z-wide -weighted: 45 dB

### Filter bands:

1/3 oct: 0,4 Hz to 5,0 Hz: 45 dB (1/3 Wide setup selection)

1/3 oct: 6.3 Hz to 250 Hz: 10 dB (normal frequency selection)

1/3 oct: 315 Hz to 20 kHz: 5 dB (normal frequency selection)

Noise measured with Nor1225 microphone and pre-amplifier Nor1209, averaged over 30 s of measurement time:

**Spectral weighting functions:**

A-weighted: 18 dB  
 C-weighted: 22 dB  
 Z-normal -weighted: 30 dB  
 Z-wide -weighted: 50 dB

**Filter bands:**

1/3 oct: 0,4 Hz to 5,0 Hz: 45 dB (1/3 Wide setup selection)  
 1/3 oct: 6.3 Hz to 250 Hz: 15 dB (normal frequency selection)  
 1/3 oct: 315 Hz to 20 kHz: 10 dB (normal frequency selection)

Noise measured with the input terminal on the sound level meter short-circuited to ground, averaged over 30 s of measurement time:

**Spectral weighting functions:**

A-weighted: 10 dB  
 C-weighted: 10 dB  
 Z-normal -weighted: 15 dB  
 Z-wide -weighted: 15 dB

**Filter bands:**

1/3 oct: 0,4 Hz to 5,0 Hz: 0 dB (1/3 Wide setup selection)  
 1/3 oct: 6.3 Hz to 250 Hz: 0 dB (normal frequency selection)  
 1/3 oct: 315 Hz to 20 kHz: 7 dB (normal frequency selection)

**Field calibration**

The recommended sound calibrator for verification of the sensitivity of the sound level meter is Norsonic Nor1251 with a nominal sound pressure 114.0dB at 1 kHz. In order to compensate for effects due to diffraction around the microphone, we recommend adjusting the sound level meter to indicate 113.8 dB (diffuse correction off).

If other types of calibrators or electrostatic actuators are used for the calibration, we recommend adjusting the sound level meter to indicate the following levels referred to the sound pressure acting on the diaphragm of the microphone (diffuse correction off):

<b>Freq Level</b>	<b>125 Hz</b>	<b>250 Hz</b>	<b>1 kHz</b>	<b>4 kHz</b>	<b>8 kHz</b>
	0.0 dB	0.0 dB	-0.2 dB	-0.8 dB	-2.8 dB

**Measurement duration and resolution**

The total time period for a measurement (global period, designated  $\Sigma$ ) may be set from 1 second up to 200 hours less 1 second with 1 second resolution. The global period may be subdivided in shorter periods, designated time resolution ( $\Delta$ ) from 1 second up to the global period. As an option the time resolution may be set in an additional range: from 50 millisecond and upwards to 1 second in steps of 25 millisecond.

**Timing accuracy**

The measurement duration and resolution is locked to the extremely accurate internal clock. Within the temperature range 0°C to +40°C the maximum drift is  $\pm 3$  ppm corresponding to an accuracy of better than 10 seconds per month. Aging for 10 years may increase the figure with additional 13 seconds per month.

## Measurement range

### Total range for measurement of A-weighted levels

The linear operating range is identical to the total range.

Frequency	31.5 Hz	1 kHz	4 kHz	8 kHz	12.5 kHz
<b>Upper level</b>	98 dB	137 dB	138 dB	136 dB	133 dB
<b>Lower level</b>	24 dB	24 dB	24 dB	24 dB	24 dB
<b>Ref level test</b>	94 dB	114 dB	114 dB	114 dB	114 dB

The primary indicator range for compliance with IEC 60651 type 1 is 24 dB to 117 dB. For compliance with IEC 60804 type 1, the linearity range is 24 to 137 dB, and the pulse range 24 dB to 140 dB, respectively

### Total range for measurement of C-weighted levels

The linear operating range is identical to the total range.

Frequency	31.5 Hz	1 kHz	4 kHz	8 kHz	12.5 kHz
<b>Upper level</b>	134 dB	137 dB	136 dB	134 dB	131 dB
<b>Lower level</b>	30 dB	30 dB	30 dB	30 dB	30 dB
<b>Ref level test</b>	114 dB	114 dB	114 dB	114 dB	114 dB

### Total range for measurement of Z-normal - weighted levels

The linear operating range is identical to the total range.

Frequency	31.5 Hz	1 kHz	4 kHz	8 kHz	12.5 kHz
<b>Upper level</b>	137 dB	137 dB	137 dB	137 dB	137 dB
<b>Lower level</b>	40 dB	40 dB	40 dB	40 dB	40 dB
<b>Ref level test</b>	114 dB	114 dB	114 dB	114 dB	114 dB

### Total range for measurement of Z-wide -weighted levels

The linear operating range is identical to the total range.

Frequency	3.15 Hz	31.5 Hz	1 kHz	4 kHz	8 kHz	12.5 kHz
<b>Upper level</b>	137 dB	137 dB	137 dB	137 dB	137 dB	137 dB
<b>Lower level</b>	50 dB	50 dB	50 dB	50 dB	50 dB	50 dB
<b>Ref level test</b>	114 dB	114 dB	114 dB	114 dB	114 dB	114 dB

### Measurement range for C-weighted peak levels

Frequency	31.5 Hz	1 kHz	4 kHz	8 kHz	12.5 kHz
<b>Upper level</b>	137 dB	140 dB	139 dB	137 dB	134 dB
<b>Lower level</b>	45 dB	45 dB	45 dB	45 dB	45 dB
<b>Ref level test</b>	114 dB	114 dB	114 dB	114 dB	114 dB

## Power supply

**Battery:** 4 cells, IEC LR6, AA-sized, Alkaline batteries are recommended (e.g. Duracell Ultra M3). AA-sized NiCd or NiMH rechargeable batteries may be used, but must be charged outside the instrument. Battery voltage and time on battery since last change of batteries are indicated.

**Typical battery life time** (Duracell Ultra M3): 8 hours.

**External DC:** 11 – 16 volt. Power consumption approximately 1.2 watt dependent on selected modes of operation. External DC source should have source-impedance less than 1 ohm and be able to supply at least 300 mA. The mains adaptor Nor340 is recommended for use with the instrument.

If the external supply falls below 9V, the instrument will use the internal batteries if available. If the instrument has switched off due to loss of power or insufficient supply voltage, the instrument will automatically switch on and resume normal operation after reapplying the external DC supply.

**Socket for external bc:** 1.3 mm plug, negative voltage on centre terminal.

The instrument will automatically switch off if the battery or external voltage is too low for operation within the stated specifications. The maximum battery voltage for conformance testing is  $4 \times 1.6 \text{ V} = 6.4 \text{ V}$ .

The instrument has a calendar clock powered from the batteries or external DC-supply. The clock is supplied from a charged capacitor during change of batteries. Contact your Norsonic service department for change of this component. After replacement the instrument need factory calibration and to re-install the options.

### Display

The display is a monochrome, transreflective LCD graphical display with 160×240 pixels (W×H) with automatic temperature compensation for contrast and viewing angle. Pressing the light key illuminates the display. The light switches off automatically 2 minutes after the last operation of any key.

The bar graph display covers 80 dB, which may be scrolled in 10 dB steps to cover the total range.

### Keyboard

The keyboard is of silicon-rubber type.

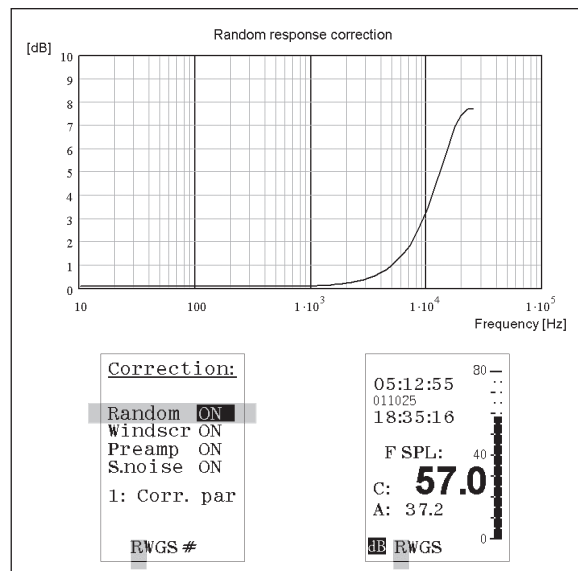

### Adjustment of indicated levels

**Random response.** The instrument is equipped with a microphone with flat free-field response and satisfies the class 1 requirements in IEC 61672-1 to free-field response. By selecting the random response correction network included, the instrument will satisfy the class 1 requirements in IEC 61672-1 to random response as well as ANSI S1.4-1997 type 1. The nominal correction to obtain flat random response is shown in the figure above.

### Activating random response correction:

- Press **SETUP** > **1** (Instr.) > **6** (Correct.) to gain access to the Corrections menu. Navigate in the menu as usual and activate the correction parameter Random by means of the **INC** and **DEC** keys. Do the same to deactivate. Random response correction activated is indicated by an “**R**” in the lower line of the display.



## Windscreen

The instrument may be used with windscreen Nor1451. The windscreen correction has to be switched on to obtain the stated specifications when the windscreen is mounted. The nominal correction for the windscreen correction network is shown in the figure above.

### Activating windscreen correction

- Press **SETUP > 1 (Instr.) > 6 (Correct.)** to gain access to the Corrections menu. Navigate in the menu as usual and activate the correction parameter Windscr by means of the **INC** and **DEC** keys. Do the same to deactivate. Windscreen correction activated is indicated by a **“W”** in the lower line of the display.

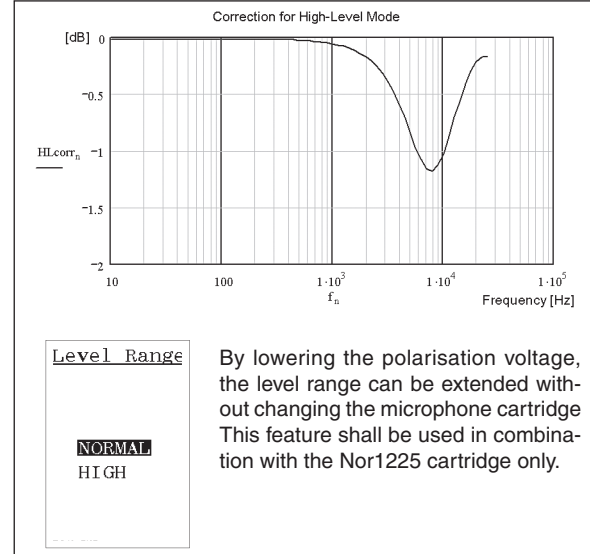
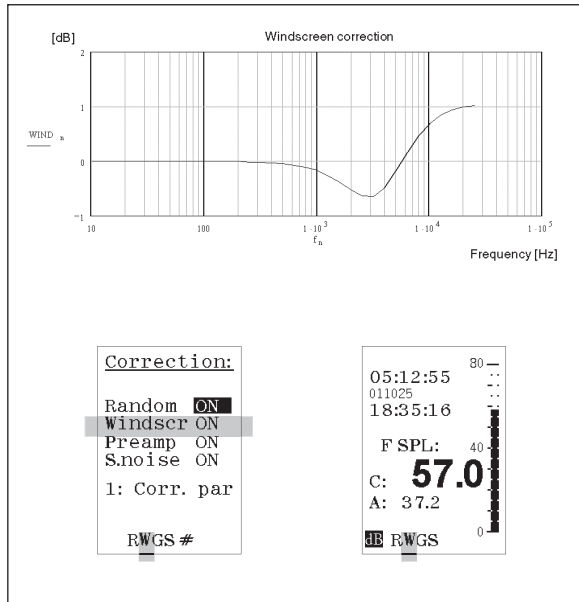

## High levels

As an option, the instrument may measure levels 10 dB higher than stated as the standard range. The extended measurement range is obtained by reducing the sensitivity of the microphone through the application of a lower polarisation voltage. When this option is selected, the polarisation voltage is lowered from 200V to about 70V. A correction network is applied automatically to compensate for the change in frequency response of the microphone due to the lower polarisation voltage. The nominal response for the "high level correction network" is shown in the adjacent figure.

Note that the needed correction will depend on the type of microphone, and shall only be applied when using microphone cartridge type Nor1225.

### Activating the high level range:

- Press **SETUP > 5** (Lvl.range) to gain access to the level range setting menu. Navigate in the menu as usual.

### Preamplifier attenuation

The instrument has the ability to correct for the attenuation in the preamplifier. Typical value of the attenuation is 0.7dB. The correction can be set in the range 0.0 to 9.9dB. The correction can be switched on/off to facilitate applications of other transducers without preamplifier. The correction is automatically switched off if IEPE-type of preamplifier is selected.

### Activating the preamplifier attenuation:

- To activate the preamplifier attenuation press **SETUP > 1** (Instr.) > **6** (Correct.) to gain access to the Corrections menu. Navigate in the menu as usual and activate the correction parameter Preamp by means of the inc and dec keys. Do the same to deactivate. Preamplifier attenuation activated is indicated by a **G** (for Gain) in the lower line of the display

### Setting the amount of attenuation:

- In the Correction menu, press **1** (Corr.par) to gain access to the correction parameter setup menu. Press **2** to gain access to the attenuation setting itself. Never change this setting unless you know what you're doing! Use the numerical keypad to set the attenuation value. Press **ENTER** twice to leave the menu. See Fig. on the previous page for menu details

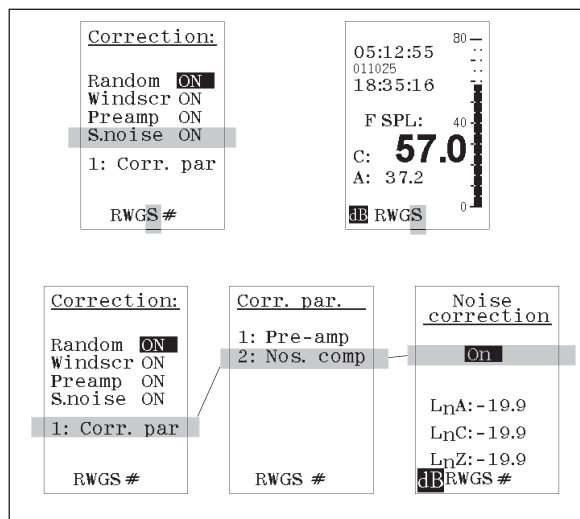
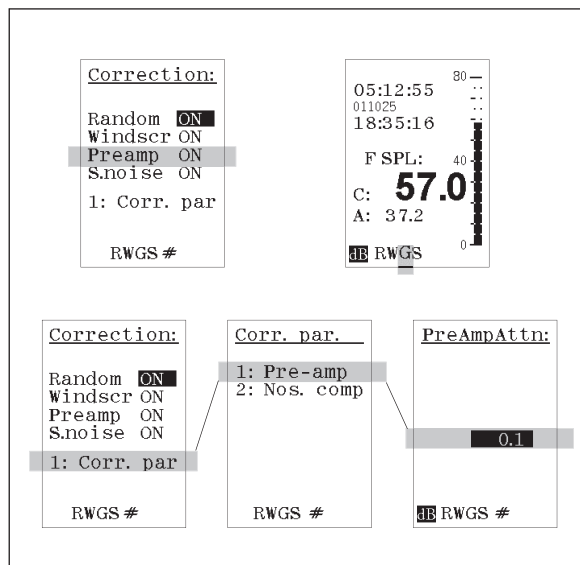

### Self-noise compensation

The displayed values for A-, C- and Z-normal -weighted levels may, as an option (extension 18), be corrected automatically for the self-noise of the microphone. Using the Z-wide network together with the self noise compensation function is not recommended due to increased self noise in the low frequency part.

### Diffraction around the instrument casing

The instrument casing is designed to have low effects on the sound measured at the microphone. The figure below shows the measured effect of the instrument casing at reference environmental conditions.

Directional plot –  
 Microphone with extension cable

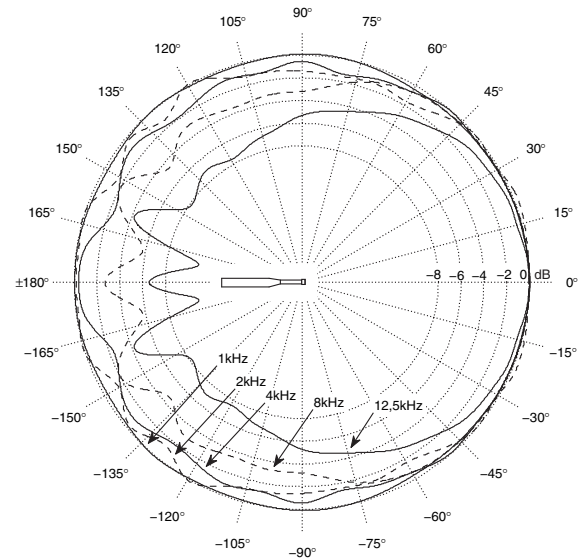
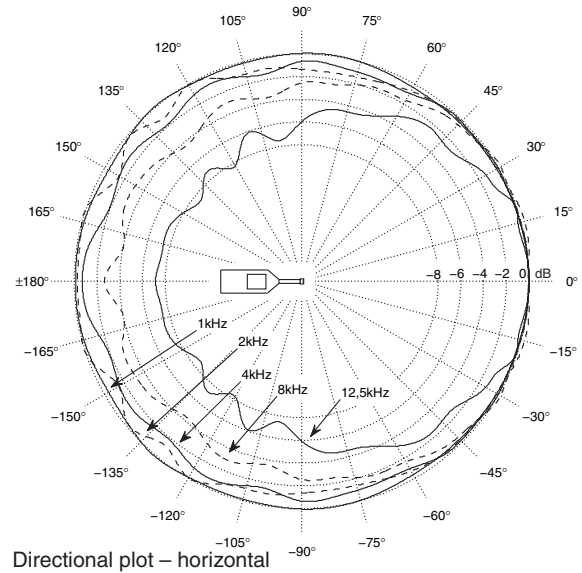
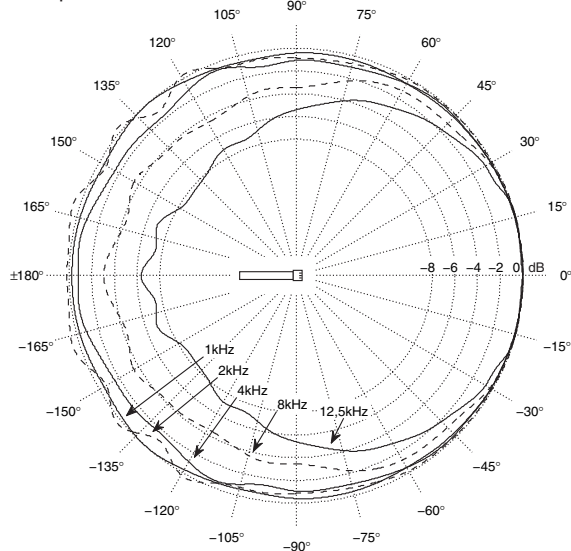

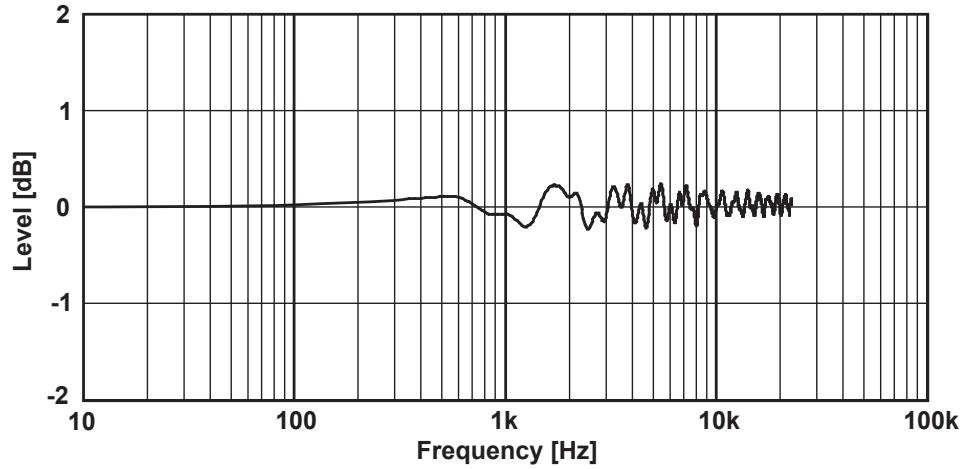

Effect of the case reflection for sound approaching the microphone from the front.  
The diagram shows the frequency response for an instrument with casing relative to the response for the microphone alone.

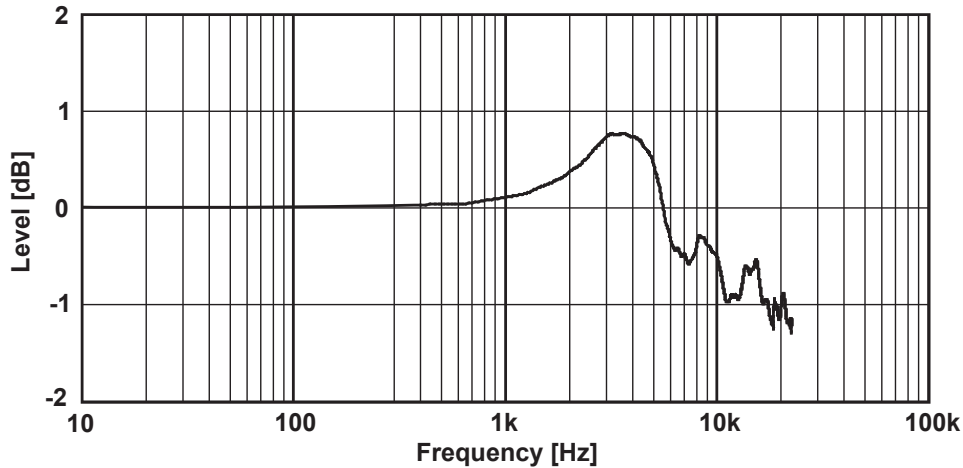

Effect of the windscreen Nor1451 for sound approaching the microphone from the front.  
The diagram shows the frequency response for an instrument with windscreen relative to the response for an instrument without.

The general I/O socket



Pin	Signal	Dir.	Remarks
1	DO-1	Out	Digital output
2	DO-2	Out	Digital output
3	DO-3	Out	Digital output
			Reserved for calibration. (high = calibration ON)
4	RTS	Out	RS232
5	TXD	Out	RS232
6	PWR	Out	3.3V, max 10mA
7	RES	In	Reset
8	DI-1	In	Digital input - Reserved for ext.trig.
9	DI-2	In	Digital input
10	DI-3	In	Digital input
11	DO-4	Out	Digital output
12	CTS	In	RS232
13	RXD	In	RS232
14	GND		ref. analogue signal
15	AC-out	Out	Noise output
Housing	GND		Instrument casing

## Signal output

An analogue output from the internal signal (noise) generator.

**Max output voltage:**  $\pm 10$  volt.

**Output impedance:**  $< 100$  ohm. The output is short-circuit proof to GND and output current is in excess of 3 mA

**Gain accuracy at 1 kHz:**  $\pm 0.2$  dB.

**Frequency response re. 1 kHz:**

$\pm 0,5$ dB for  $20 \text{ Hz} < f < 16 \text{ kHz}$ .

## Serial I/O port

RS232 port, 9600 – 115200 baud. The port may be switched off to reduce power consumption, which should be considered if a cable is attached to the socket.

## Digital inputs

The digital input signals are 3.3V CMOS signals. The voltage levels must be within  $-0.25\text{V}$  to  $+5.25\text{V}$  to avoid harming the instrument.

**Input impedance:** 10 kohm connected to the positive supply 3.3 volt. Any open input will therefore be in the high state.

## Digital outputs

The digital output signals are 3.3V CMOS signals.

**Maximum output impedance:** 100 ohm. During power-up the output lines will be low or in a high-impedance state (100 kohm to ground).

### Digital output control lines

The Nor140 instrument has 4 digital output lines which all can be used to control external devices or functions based on the internal status of the instrument. The digital output lines are named DO-1 to DO-4 (see the pin configuration of the general I/O sockets for connection details).

The function of each digital output line is selected by the user through the Digital I/O menu found by using the key sequence **SETUP – 1**: Instrument menu – 2:IO/Print – 1:DigIO. The following functions are available for each of the four output lines:

- OFF** No function on this output line (output level continuously low(0))
- USER** Output level high (1) or low (0) is controlled via remote operation of the Nor140 instrument (see remote command list for details).
- CAL** Output level is high (1) as long as the instrument is performing the calibration procedure, either manually through the Calibration menu, or remotely from an external software.
- GO** Output level is high (1) when the “Go / NoGo” quality control comparison test of the Reference Spectra is successfully fulfilled (see chapter 18 for details).
- BUSY** Output level is high (1) when the “Go / NoGo” quality control feature of the Reference Spectra is in operation (see chapter 18 for details).
- OVL** Output level is high (1) as long as the instrument detects an input signal above the operational dynamic range (“Overload”).

**RUN** Output level is high (1) as long as the instrument is in the Running status (i.e. the Nor140 is making a measurement).

**REC** Output level is high (1) as long as the instrument is making an audio recording of the input signal.

Some features in the instrument may force the digital output line into preset settings which avoid the user from using the above selection for one or more of the output lines. The Nor140 has the following preset settings:

**The microphone check feature** is controlled from point 7 in the Misc.menu found using the key sequence **SETUP – 1**: Instrument menu – **9**: Misc.par. By turning on the DO-3 setting, the digital output line 3 will be permanently connected to the microphone check feature independent of any previous setting. Turning OFF this feature will allow normal user setting of the DO-3 again.

**The Nor1516 feature** used for wireless operation during building acoustics measurement as part of the Nor1516 system is controlled from point 3 in the Misc.menu found using the key sequence **SETUP – 1**: Instrument menu – **9**: Misc.par. By turning on the Nor1516 feature inside the Nor140, the digital output lines 1 and 2 will be permanently set to **SPK** and **DECT** respectively. These settings are required for normal operation of the wireless system. Turning OFF this feature will automatically set DO-1 and DO-2 to OFF again.

**The “GO / NOGO” comparison feature** described in chapter 18 is turning the digital output lines 1 and 2 to the permanently setting as **BUSY** and **GO** respectively. Turning OFF this feature will allow normal user setting of the DO-1 and DO-2 again.

If both the Nor1516 and the “Go / NoGo” features are turned on simultaneously, the digital output settings of the Nor1516 will have priority.

### AC-out

3,5 mm stereo jack. Both channels have identical signals driven by two separate amplifiers. Load impedance shall be 16 ohm or more. Output voltage is generated by the 48 kHz DAC based on data from DSP. Normally a replica of the normalised microphone signal. Full scale on the display bargraph corresponds to 100 mV.

**Output impedance:** Less than 10 ohm, AC-coupled 100  $\mu$ F.

**Gain accuracy 1 kHz:**  $\pm 0,2$  dB

**Frequency response re. 1 kHz:**  $\pm 0,5$  dB for  $20 \text{ Hz} \leq f \leq 16 \text{ kHz}$ .

### RPM

MMCX male connector.

### USB interface

USB type 2.0

**USB socket:** B411

### SD-card

The instrument may use SD-card for storing of setup information, sound recordings and measurement result.

**Memory size:** Supports cards up to 32GB following the SDSC and SDHC. It is recommended to use industrial grade types which are manufactured with

SLC NAND Flash chips for extra-long life and stability. These cards have fewer errors in reading and writing than commercial SD cards.

Please note that no file in the system may exceed the 4 GB limit. This file size is only possible to achieve with audio recordings, and it corresponds to a recording of approximately 8 hours using 48 kHz sampling 24 bit resolution or 92 hours of 12 kHz 8 bit resolution.

### Data storage

Measured data is stored in the internal memory of the sound level meter or on the SD-card. The internal memory is of the “flash” type retaining the information without battery supply. Approximately 25 Mbyte is available for the data storage.

### Environmental conditions

**Reference conditions.** The reference conditions for the instrument are as specified by IEC 61672-1

**Temperature:** 23°C

**Humidity:** 50% RH

**Atmospheric pressure:** 101.325 kPa

### Environmental condition for operation

**Temperature:**  $-10^{\circ}\text{C}$  to  $+50^{\circ}\text{C}$

**Humidity:** 5% to 90% RH, dewpoint less than  $40^{\circ}\text{C}$

**Atmospheric pressure:** 85 kPa to 108 kPa

### Environmental condition for storage

**Temperature:**  $-30^{\circ}\text{C}$  to  $+60^{\circ}\text{C}$

**Humidity:** 5% to 90% RH, dewpoint less than  $40^{\circ}\text{C}$

**Atmospheric pressure:** 50 kPa to 108 kPa

### Warm-up time

The warm-up time for the main instrument without preamplifier/microphone is very short and the instrument obtains the final accuracy as soon as the self-test is made. Used with a preamplifier and microphone, this time is prolonged due to the charging of the microphone with the polarisation voltage. Normal sensitivity is reached within one minute. Before a recalibration is attempted, at least three minutes for warm-up is recommended.

### Sensitivity for vibration

If the instrument is used under strong vibrational conditions, it is recommended to use an extension cable between the preamplifier and the instrument body. The vibration will mainly affect the microphone, which is most sensitive if the vibration is applied perpendicular to the diaphragm. Typical values are 55 dB to 65 dB for acceleration values of  $1 \text{ ms}^{-2}$  perpendicular to the diaphragm.

### Sensitivity for magnetic fields

The maximum indication for exposure to magnetic field of 80 A/m and any orientation is typically less than 20 dB.

### Size and weight

**Depth:** 30 mm

**Width:** 75 mm

**Length, excl. microphone/preamplifier:** 210 mm

**Length, incl. microphone/preamplifier:** 292 mm

**Weight incl. batteries:** 410 g

### Information for conformance testing

**Reference Sound Pressure Level:** 114.0 dB re 20  $\mu\text{Pa}$ . The reference frequency is 1000 Hz.

**Reference Level Range:** The instrument has one level range only.

**Microphone Reference Point and Direction:** The microphone reference point is the geometric centre of the diaphragm of the microphone. The microphone reference direction is from the microphone and along the axis of rotational symmetry for the microphone and preamplifier.

**Battery voltage:** The instrument will automatically switch off if the battery or external voltage is too low for operation within the stated specifications. The max. battery voltage for conformance testing is  $4 \times 1.6 \text{ V} = 6.4 \text{ V}$ .

**Electromagnetic Compatibility:** When the instrument is tested for conformance to electromagnetic compatibility requirements, the instrument should be in the measurement mode, as this normally will generate the highest levels of emissions. The highest susceptibility is normally observed when the display faces the principal direction of propagation for the electromagnetic field.

For further information related to type approval periodic verification, consult the factory.





# Index

## A

- Accelerometer 168
- Alarm Output. **See** Reference Spectrum
- Audiometer calibration 173
- A-weighted 34
  - A-weighted spectrum 34
- Absolute time 5
- Airborne sound insulation 135
  - Terms and definitions for airborne sound insulation 133
- Automatic storing 69

## B

- Back-erase 44, 48
  - No back-erase in profile pause mode 44, 48
- backup storage 12
- Batteries 11
- Battery Low (BATLOW) 12
- Building Acoustics 131
  - Airborne sound insulation 135
  - Façade insulation 147
  - Impact sound insulation 144
  - Service equipment sound pressure levels 150
  - Survey and engineering method 134
  - Terms and definitions for airborne sound insulation 133
  - Terms and definitions for impact sound insulation 134

## C

- charge accelerometer 170
- C-weighting 23
- Calibration 17, 59
  - Engineering units 59
- Calibrator 18, 19
- Charging 12
- CIS-value 164
- Clearing 67, 68
  - Clearing a single file 67
  - Clearing folders or the entire memory 68
- Compensation 100
  - Diffuse sound fields 101
  - Low sound levels 101
  - Random incidence 101
  - Self-noise 102
  - Windscreen 100
- Conformance testing 188

## D

- Diffraction around the instrument casing 183
- Diffuse response
  - Diffuse sound fields 101
  - Random incidence 101
- Diffuse sound fields 101
- Digital inputs 185
- Digital outputs 185
- Duration 21, 42
  - Measurement duration 22
  - Missing percentiles? 22

## E

- Engineering units 58
  - Calibration 59
  - How values are indicated 58
- Environmental conditions 187
- Extensions 7
  - Extensions installed 8
  - Extension menu 8
  - Options available 10

## F

- Façade insulation 147
- Fast Fourier Transformation. **See** FFT
- FFT 165
  - Calibration 166
  - Corrections 166
  - Specification for FFT 167
- Filters: 176
- Format 62
- Free-field microphones 18
  - Calibration 18
- Frequency analysis 30
  - A-weighted spectrum 34
  - Activating the frequency mode 32
- Front panel keys 16
- Functions 2, 25

## G

- Global 41
- "Go / NoGo" Quality Control feature 96

## H

- Hardcopies 72
- Headphones 84
- Highpass filter 175
- High sound levels 102, 181

## I

- IEPE 8
- IEPE accelerometer 169
- ICP 83
- Impact sound insulation 144
  - Terms and definitions for impact sound insulation 134
- impulse response method 111
- input terminal 83
- interrupted noise method 113

## K

- Keeping track of the measurement mode the file was stored in 67
- Keyboard 16
  - Keyboard lockout 70

## L

- language 15
- level vs. time 41
- Listen, Signal output 84
- L(t) 45
  - Presenting the L(t) as a table 45
- Level detector 176
- Low sound levels 101

## M

- Magnetic fields 188
- Manual storing 69
- Markers 50
  - Adding markers to a measurement 50
  - Other markers inserted by the instrument 51
  - P and S markers have priority 51
  - The key to use 50
- Measurement mode
  - Keeping track of the measurement mode the file was stored in 67
- Measurement range 175, 179
- Measuring vibration 168
- Memory 61, 67
  - Clearing a single file 67
  - Clearing folders or the entire memory 68
  - Memory structure 61

- Retrieving stored setups and data 64
- SD-card 61
- Select the device for storing 62
- Standard set-up 65
- Storing a measurement 64
- Storing a measurement setup 62
- Menus 13, 21
  - Navigating in 13
- Microphone check 20
- Microphone input socket 175
- Microphone preamplifier. **See** Preamplifier
- Mode 67
  - Keeping track of the measurement mode the file was stored in 67
- Mode dependent parameters 64
- Multispectrum measurements 6, 52
  - Making multispectrum measurements 53
  - Result tables 55
  - Setting up for multispectrum 52
  - To move the cursor along the time profile axis 54
  - To see the level vs. time (the profile) graph of another frequency band 55
  - To see the spectrum of another moment in time 54

## N

- NC rating 40
- negative trigger delay 90
- Noise excitation 135
- Noise Generator 98
  - Reverberation measurement 99
  - Selecting noise type and level 98
- Nor263A 87, 91
- NorXfer 75
- NR rating 40

## O

- Octaveband 32
- Options. **See** Extensions
- output control lines 186

## P

- Password 75
- Pause 24
  - The back-erase feature 25, 34
- Polarisation voltage 12
- power fail 12
- Power (Sound) 117
- Power supply 179
- Preamplifier 14, 182
  - Attenuation 182
- Prepolarised microphone 13
- pre-trigger 90
- Printouts 72
- Profile 41, 44, 48
  - No back-erase in profile pause mode 44, 48

## R

- Random incidence 101
- RASTI 154
- RC rating 40
- Real time frequency analysis 4
- Recording 89
  - Formats 89
  - Recording duration 90
  - Recording gain 89
  - Setup for a recording 91
  - Starting a recording 90
- Reference Spectrum 94
  - Activating the ReferenceSpectrum features 94
  - Digital output lines 97
  - Editing a selected Reference Spectrum 96
  - Entering a new Reference Spectrum manually 95
  - Go/NoGo Quality Control feature 96
  - Selecting the Reference Spectr 94
  - Using a previously measured spectrum 95
- reference tone 93
- Relative time 5
- remote hand switch Nor263A 87, 91
- Repeat 70
- Resolution 42
- Resolution time 42
- Result 45
  - Presenting the L(t) as a table 45
- Result tables 26
- Reverberation time 104
  - Excitation signals 109
  - Impulse response method 111

Interrupted noise method 113  
 Minimum reverberation time possible 109  
 What is reverberation time? 104  
 RPM 84, 187

## S

SD-card 61, 187  
 Selecting language 15  
 Self-noise compensation 102  
 Self-noise levels 177  
 Serial interface 75  
 Service equipment sound pressure levels 150  
 Setups  
     Mode dependent parameters 64  
     Storing a measurement setup 62  
 Signal out 83  
 Signal output 84  
 Sound Power 117  
     About sound power measurements 117  
     Acoustic environment requirements 124  
     Measuring the sound power 126  
 Source coding 6  
 Specifications 174  
 Speech Intelligibility 153  
     CD for excitation 156  
     Development of STI 153  
     Excel sheet 156  
     How is STIPA measured 155  
     Selecting a loudspeaker for the excitation 158  
 Speech transmission index. **See** Speech Intelligibility  
 Start 24  
     Start a measurement 24  
 Statistics 22  
     Displaying the percentiles 27  
     User-defined percentile 28  
 STI 153. **See** Speech Intelligibility  
     Development of STI 153  
 STIPA 153. **See** Speech Intelligibility  
     How is STIPA measured 155  
 Stop 24  
     Resuming an ended measurement 25  
     The effect of pressing STOP before resuming 44  
 Storing 39, 69  
     Automatic 69  
     Automatic storing 69  
     Manual 69  
     Repeat 70  
     Retrieving stored setups and data 64

Select the device for storing 62  
 Standard set-up 65  
 Storage modes 69  
 Storing a measurement 64  
 Storing a measurement setup 62  
 Storing the acquired data 39  
 Synchro 70  
 Swept-Sine 151  
 Swept Sine, reverberation 115  
 Synchro 70

## T

Table 45  
     Presenting the L(t) as a table 45  
 Technical specifications 174  
     AC-out 187  
     Calibration 178  
     Conformance testing 188  
     Diffraction around the instrument casing 183  
     Digital inputs 185  
     Digital outputs 185  
     Environmental conditions 187  
     Frequency weightings 176  
     Highpass filter 175  
     Indication range 177  
     Level detector 176  
     Level distribution 177  
     Measurement range 175  
     Microphone input socket 175  
     Power supply 179  
     Preamplifier attenuation 182  
     Range for C-weighted peak levels 179  
     Range for measurement of A-weighted levels 179  
     Range for measurement of C-weighted levels 179  
     SD-card 187  
     Self-noise levels 177  
     Sensitivity for magnetic fields 188  
     Sensitivity for vibration 188  
     Serial I/O 185  
     Signal output 185  
     Type of instrument 174  
     USB interface 187  
     Warm-up time 188  
     Windscreen 181  
     Windscreen correction 181  
 Time constant 23  
     Instruments with multiple time constants 23  
 Time profile 5, 41

- Selecting which functions to log 46
- Trigger 85
  - Clock trigger 86
  - External trigger 87
  - Level above-trigger 87
  - Manual trigger 86, 91
  - Setting the trigger condition 86

## **U**

- Units 58
  - How values are indicated 58
- USB interface 75, 187
- User defined table 29

## **V**

- Velocity 171
- vibration measurements 168
- Virtual Instrument 82

## **W**

- Weighting networks 176
- W-marker 51
- Warm-up time 188
- Windscreen 100, 181
  - Windscreen correction 181
- Workload 8

## **Z**

- Z-weighting 23







## Declaration of Conformity

We, Norsonic AS, Gunnersbråtan 2, N-3408 Tranby, Norway, declare under our sole responsibility that the product:

### Sound Level Meter / Real Time Analyser Nor140

to which this declaration relates, is in conformity with the following standards or other normative documents

Standards:	IEC61672-1 Class 1	ANSI S 1.4 1983 type 1
	IEC 60651 Type 1	ANSI S 1.43 1997 class 1
	IEC 60804 Type 1	ANSI S1.11-2004 class1
	IEC 61260 class 1	EN 61010-1: February 2001

following the provisions of the EMC-Directive.

This product has been manufactured in compliance with the provisions of the relevant internal Norsonic production standards. All our products are tested individually before they leave the factory. Calibrated equipment – traceable to national and international standards – has been used to carry out these tests.

During the RF emission test the following was connected: USB cable (1m), mains adapter NOR 340, microphone preamplifier NOR1209 and microphone NOR1225. Setup: Measurement duration 1h, Frequency mode parallel; 1/1 octave, 2nd network Z.

During the RF immunity test the following was connected: USB cable (1m), microphone preamplifier, NOR1209 and microphone NOR1225. Setup: Frequency mode parallel; 1/1 octave, 2nd network Z. Orientation: Laying face up on the table and the microphone was pointing towards the antenna.

During the AC power frequency field test the following was connected: microphone preamplifier NOR1209 and microphone NOR1225. Setup: Frequency mode parallel; 1/1 octave, 2nd network Z.

The orientation of the instrument in the magnetic field had no influence. During the ESD test the SPL value may show some fluctuations from the ESD pulse. Power supply: Battery voltage 4-6.4V. External DC voltage 11-16V.

This Declaration of Conformity does not affect our warranty obligations.

Tranby, October 2006



Dagfinn Jahr  
Quality Manager

The declaration of conformity is given according to EN 45014 and ISO/IEC Guide 22.

Norsonic AS, P.O. Box 24, N-3421 Lierskogen, Norway



P.O. Box 24  
N-3421 Lierskogen  
Norway  
Tel: +47 3285 8900  
Fax: +47 3285 2208  
info@norsonic.com  
www.norsonic.com

**Norsonic AS** supplies a complete range of instrumentation for acoustics – from sound calibrators, microphones and preamplifiers; via small handheld sound level meters to advanced, yet portable, real time analysers, but also spectrum shapers, building acoustics analysers and complete community, industry and airport noise monitoring systems. Contact your local representative or the factory for information on our complete range of instrumentation.